



Flow Simulation Study on Bed Bath for Bedridden Patient

N. H Mokhtar¹, N. F Azmi^{2,*}, B. R Mizah³, Abdul Rafeq Saleman³, M H Ismail¹

¹ Fakulti Teknologi Kejuruteraan Mekanikal dan Pembuatan, Universiti Teknikal Malaysia Melaka, Malaysia

² Fakulti Kejuruteraan Elektronik dan Kejuruteraan Komputer, Universiti Teknikal Malaysia Melaka, Malaysia

³ Fakulti Kejuruteraan Mekanika, Universiti Teknikal Malaysia, Melaka, Malaysia

ARTICLE INFO

Article history:

Received 22 June 2023

Received in revised form 21 July 2023

Accepted 20 August 2023

Available online 12 December 2023

ABSTRACT

Easy tasks such as showering or bathing independently are impossible for a bedridden individual. This paper presents a comprehensive study on designing an easy shower specifically tailored for bedridden patients. The challenges bedridden individuals face in maintaining personal hygiene are highlighted, emphasizing the importance of a suitable bathing system to enhance their quality of life. The proposed design aims to address these challenges and improve caregiving efficiency. The chosen methodology involves a weighted decision matrix to select the optimal design, followed by flow simulation using SolidWorks Flow Simulation software to evaluate its performance. The paper's objectives include designing an efficient easy shower model, assessing its performance via simulation, and analyzing the impact of various velocity settings on its functionality. Three design concepts were proposed, with Design A selected as the optimal choice due to its lightweight, high water capacity, ease of handling, and low production cost. Modifications were made to enhance its water pressure efficiency. The simulation encompassed different velocity settings, with flow trajectories analyzed within the tank and at the water outlet. These boundary conditions included analysis type (internal), fluids (water), default wall thermal condition (adiabatic wall), pressure (101325 Pa), temperature (293.2 K), and velocity in the Y direction (5 m/s for water inlet and 0.5 m/s for water outlet). In the first simulation, all the results obtained were within the specified velocity range of 0.5 m/s, 2 m/s, and 5 m/s. The analysis of flow trajectories revealed distinct flow patterns and velocities for different velocity values, indicating stable and controlled environments within the tank and efficient water discharge through the outlet in Design A. However, errors were observed in the water outlet simulation due to the presence of vortices, which impacted the results. Recommendations were made to address these challenges, such as modifying the design to eliminate or minimize vortex effects. In conclusion, this study contributes to the well-being of bedridden patients by proposing an improved bathing mechanism, enhancing caregiving efficiency, and offering insights into design optimization and simulation challenges. The proposed design could have a significant positive impact on the lives of bedridden patients and caregivers.

Keywords:

Easy Bath; Bedridden patient; Fluid Flow Simulation

* Corresponding author.

E-mail address: fatihah@utem.edu.my (N. F Azmi)

<https://doi.org/10.37934/cfdl.16.3.112124>

1. Introduction

The current population of Malaysia is approximately thirty-two million individuals, with projections indicating a peak of forty-two million by 2068 [1]. Around two million individuals are aged sixty-five and above, some of whom are bedridden due to age-related issues. However, bedridden conditions are not limited to the elderly, as individuals of all ages can be confined to bed due to various factors such as paralysis, vehicular accidents, orthopedic problems, and more [2]. Bedridden patients require assistance from caregivers, family members, paid caregivers, or healthcare professionals, as they are unable to engage in self-care and medical treatment [3]. Hence, providing round-the-clock care and maintaining personal hygiene is crucial for bedridden patients in home-based or institutional settings [2].

The management of bedridden patients poses significant challenges, including the need for daily monitoring by a substantial number of caregivers [2]. Bathing bedridden patients is an essential daily care task, but it is also a challenging activity that requires considerable effort and a series of movements from caregivers or nursing staff [4]. Despite its importance, bed bathing is limited and burdensome for caregivers and patients. It often takes thirty to sixty minutes to complete the activity, and the conventional methods can further prolong the time required [5].

Bed baths are primary in fundamental human care, extending beyond the basic nursing service. They have therapeutic effects on skin hygiene, blood circulation, body movements, self-image, body odor reduction, pain relief, and muscle relaxation. Nonetheless, bathing has always been recognized as an essential human need. Therefore, ensuring the healthcare of bedridden patients is of utmost importance, and caregivers or nursing staff must maintain hygiene while providing support and assistance for self-care and medical treatment. Meeting basic hygiene needs such as bed baths is crucial to prevent the spread of infections and promote dignity and care for all patients [7].

Though restrictive and burdensome, bed bathing remains an effective therapy for bedridden patients [5]. Encouraging patients to shower or bathe whenever possible is preferred. Thus, a bed bath may be the only option for fulfilling hygiene needs [7]. Studies have shown notable improvements in the general condition of bedridden patients after using a portable bathtub for bed baths. The portable bathtub provides comfort and muscle relaxation, lessening the impact of hospital admission. It also enhances nursing care, surpassing conventional practices and promoting reflection on special, creative, and adaptable treatment approaches [6]. Computational Fluid Dynamics (CFD) and mathematical modeling in the design and analysis of the portable washing system further enhance its functionality and safety. Note that Solidworks software is commonly utilized due to its user-friendly interface and comprehensive simulation tools [7].

The importance of bed baths for bedridden patients is acknowledged. However, there seems to be a lack of efficient and user-friendly bathing methods or mechanisms that address the challenges caregivers and patients face during bed baths. The existing practices are time-consuming and may not fully address the therapeutic benefits of bed baths. The study aims to propose a new bathing method or mechanism for bedridden patients, focusing on designing an easy shower model and evaluating its performance through simulation. This suggests the current research aims to bridge the gap by developing a more practical and efficient solution for bedridden patients' hygiene needs. Moreover, the gap can be further refined as researchers investigate whether the proposed easy shower model effectively addresses the challenges of bed baths for bedridden patients while considering different velocity settings that might impact its performance. This study proposes a new bathing method or mechanism for bedridden patients, focusing on designing an easy shower model and analyzing its performance through simulation. The objectives include designing a new model of an easy shower, evaluating its performance using simulation methods, and assessing the impact of

different velocity settings. Furthermore, the study will employ simulation processes to design, analyze, and evaluate the easy shower model for bedridden patients.

2. Methodology

This section will discuss the design selection, utilizing a weighted decision matrix and establishing boundary conditions for the simulation.

2.1 Concept Design

A concept design describes the product's technology, working principles, and form. Three concept designs have been developed to meet the project requirements. Although all designs are based on the same principle, each is implemented differently. The advantages and disadvantages of each design will be discussed in this subtopic. The first concept of the easy shower for bedridden patients is depicted in Figure 1. This design utilizes water pressure as its primary mechanism. When filled from a hose bib, the water pressure is transferred from the water supply to the pressure chamber tank. The second concept, illustrated in Figure 2, is similar to the first design but includes an additional feature: a stand to support the tank. The purpose of the stand is to elevate the tank slightly above the bedridden patient's level, allowing for increased water pressure and improved fluid flow. On the other hand, Figure 3 demonstrates the third concept of the easy shower for bedridden patients. This design employs a small water pump as its main component. The water pump is used to circulate the water from the tank. This design offers potential space-saving benefits compared to the other designs, as it features a round and elongated shape.

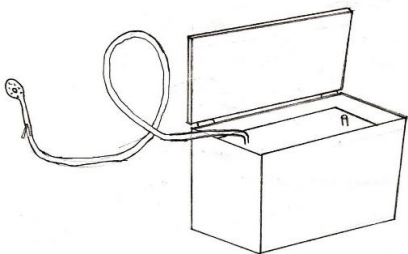

Fig. 1. Design A

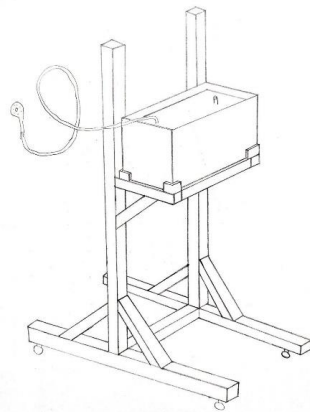

Fig. 2. Design B

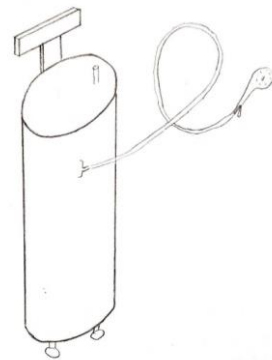

Fig. 3. Design C

2.2 Design Selection

A weighted decision matrix serves as a valuable tool in the design process, allowing for evaluating and prioritizing different design options based on a set of criteria with assigned weights. This tool aids designers in making informed decisions and selecting the most suitable and functional design option. In the provided data in Table 1, various criteria are listed, including ease of handling, ease of use, and strength, each assigned a weight reflecting its relative importance. Note that higher weights indicate greater significance in the decision-making process. For this evaluation, the criteria of ease of handling, ease of use, and strength have been assigned a weight of 5, indicating the utmost importance. The assigned values for each criterion are considered to determine the total score for

each design option. These values represent how well each design option performs concerning the specified criteria. The total score is calculated for each design option by evaluating all the criteria. Upon analysis of the results, Design A emerges as the design option with the highest total score, followed by Designs C and B. The slight difference in total scores between Design A and Design C can be attributed to variations in individual criterion scores. Design A excels in criteria such as lightweight, water capacity, and simplicity, contributing to its overall higher score compared to Design C. Moreover, Design A's outstanding performance can be attributed to its characteristics, including ease of handling, ease of use, high flexibility, and low production cost. These characteristics make Design A a favorable choice, as it offers convenience in handling and usage, provides flexibility for various applications, and proves cost-effective in production. Overall, the weighted decision matrix enables a systematic evaluation and prioritization of design options based on specific criteria, leading to well-informed decisions aligned with the project's requirements and objectives.

Table 1
 Weighted decision matrix

Criteria	Weighting	Design A		Design B		Design C	
		Score	Total	Score	Total	Score	Total
Easy to handle	5	5	25	4	20	5	25
Easy to use	5	5	25	4	20	5	25
Strength	5	4	20	5	25	4	20
Comfortable	5	5	25	4	20	5	25
Cleanliness	5	5	25	5	25	5	25
Flexibility	5	5	25	5	25	5	25
Durable material	5	4	20	5	25	5	25
Duration of bath	5	5	25	5	25	5	25
Corrosion resistance	4	5	20	5	20	5	20
Ergonomics	4	4	16	5	20	5	20
Lightweight	4	5	20	4	16	4	16
Capacity of water	4	5	20	5	20	4	16
Simple design	4	5	20	4	16	4	16
Low cost	4	5	20	4	16	5	20
Compact size	4	5	20	4	16	5	20
		Total	326	Total	309	Total	323

After analyzing Table 1, it became evident that Design A received the highest score and was consequently selected for simulation. Nonetheless, certain modifications were introduced to refine Design A. The resulting final design is presented in Figure 4. Note that these modifications specifically targeted the design model's water inlet and water outlet. Design A initially featured one water inlet and one outlet at different positions. However, one water inlet and one water outlet remain in the final design, but the positions have been aligned. The objective of this modification was to enhance the water pressure within the system. Water pressure transfer occurs from the water supply to the pressure chamber tank. The modification involved aligning the water inlet with the water outlet to mitigate any potential loss of water pressure. Moreover, the water outlet in the design model will be connected to a hose that links to the design's inlet. These modifications optimized the overall water

pressure, ensuring efficient functionality. By aligning the positions of the water inlet and outlet and incorporating the hose connection, the final design aims to improve the effectiveness of water pressure transfer during the operation. In summary, the final design's adjustments to Design A's water inlet and water outlet aimed to enhance the system's performance and functionality. These modifications contribute to the overall success of the easy shower for bedridden patients by improving the water pressure and minimizing any pressure loss [8-19].

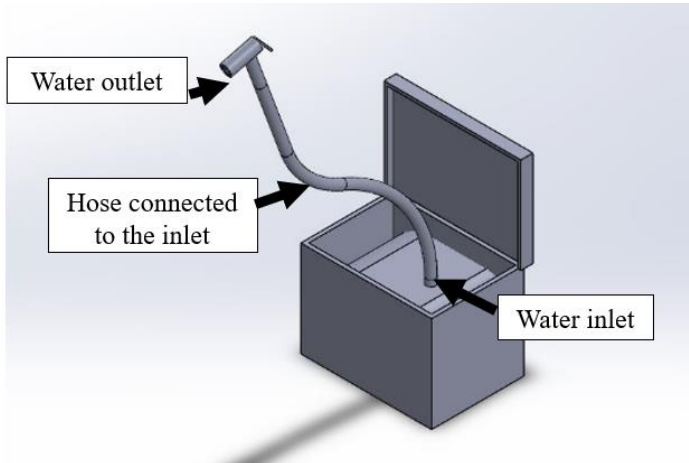

Fig. 4. Final design

2.3 Boundary Condition

The software employed for conducting the simulation is Solidworks Flow Simulation. The boundary conditions presented in Table 2 were established to define the simulation parameters. Note that they were predetermined before commencing the simulation and applied to both the water inlet and outlet design models. The specified boundary conditions encompassed various aspects, including the analysis type (internal), the fluid type (water), the default wall thermal condition (adiabatic wall), the pressure (101325 Pa), the temperature (293.2 K), and the velocity in the Y direction (5 m/s for the water inlet and 0.5 m/s for the water outlet). A specific parameter was set in this simulation to analyze the model design. Consequently, the simulation of the model design will be examined based on this predefined parameter. The chosen parameter for this design was velocity, and each simulation would incorporate a distinct velocity value as a parameter for the model design. The different values of the parameter set for each simulation are presented in Table 4 [20-26].

Table 2
 Boundary condition

Boundary condition	Boundary condition	
	Analysis type	Internal
	Fluids	Water (liquids)
	Default wall thermal condition	Adiabatic wall
	Pressure	101325 Pa
	Temperature	293.2 K
	Velocity 1	0.5
	Velocity 2	2
	Velocity 3	5

3. Results

3.1 Flow Trajectories

The analysis of flow trajectories within the tank provided valuable insights into the velocity distribution. The findings from the analysis, as presented in Table 3, indicate that different velocity values of 0.5 m/s, 2 m/s, and 5 m/s result in distinct flow patterns inside the tank. At a velocity of 0.5 m/s, the flow trajectories inside the tank exhibited velocities at the lower range. This suggests a relatively gentle flow with slower water movement. The velocity distribution appeared uniform throughout the tank, indicating a consistent flow pattern. For a velocity of 2 m/s, the flow trajectories revealed velocities in the middle range. This indicates a moderate flow rate with increased water movement compared to the lower velocity. The velocity distribution indicated slight variations across different tank sections, suggesting potential influences from fluid dynamics or obstacles within the system. At the highest velocity of 5 m/s, the flow trajectories showed velocities in the higher range near the tank's inlet. This suggests a more rapid and energetic flow in that vicinity, possibly resulting in turbulent flow patterns. However, as the water dispersed and moved away from the inlet, the velocity decreased and fell within the lower and middle ranges. This can be attributed to the dissipation of energy and the expansion of the flow within the tank.

Similar patterns can be observed by analyzing the flow trajectories presented in Table 4, which corresponds to the water outlet simulation. At a velocity of 0.5 m/s, the flow trajectory at the lid, pipe head, and pipe exhibited velocities within the lower range, indicating a controlled and steady water release through the outlet. For a velocity of 2 m/s, the flow trajectories at the lid, pipe head, and pipe displayed velocities within the middle range. This suggests a moderate flow rate, allowing effective water discharge through the outlet. The velocities observed indicate a balanced flow with efficient water dispersal. At the highest velocity of 5 m/s, the flow trajectories at the lid, pipe head, and pipe exhibited velocities within the higher range. This suggests a more forceful water release through the outlet, potentially providing stronger flushing power or water pressure. Nevertheless, it is important to note that the velocity within the tank remained within the lower range for all three velocity values, ensuring a stable and controlled environment within the system.

Overall, the analysis of flow trajectories provides valuable information for understanding the velocity distribution within the tank and at the water outlet. These insights contribute to the design's evaluation and optimization, ensuring the system's desired performance and functionality.

Table 3
 Flow trajectory inside the water tank

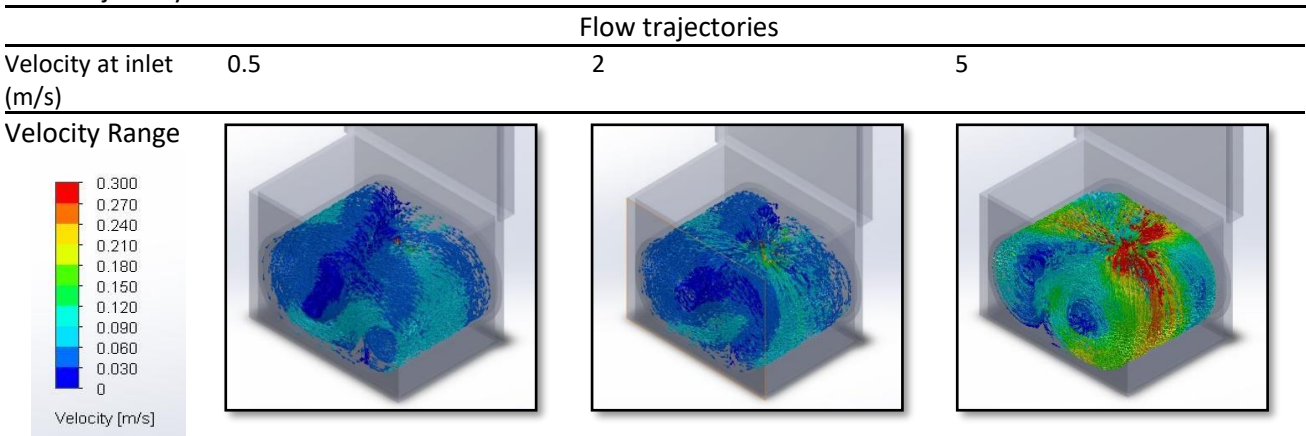
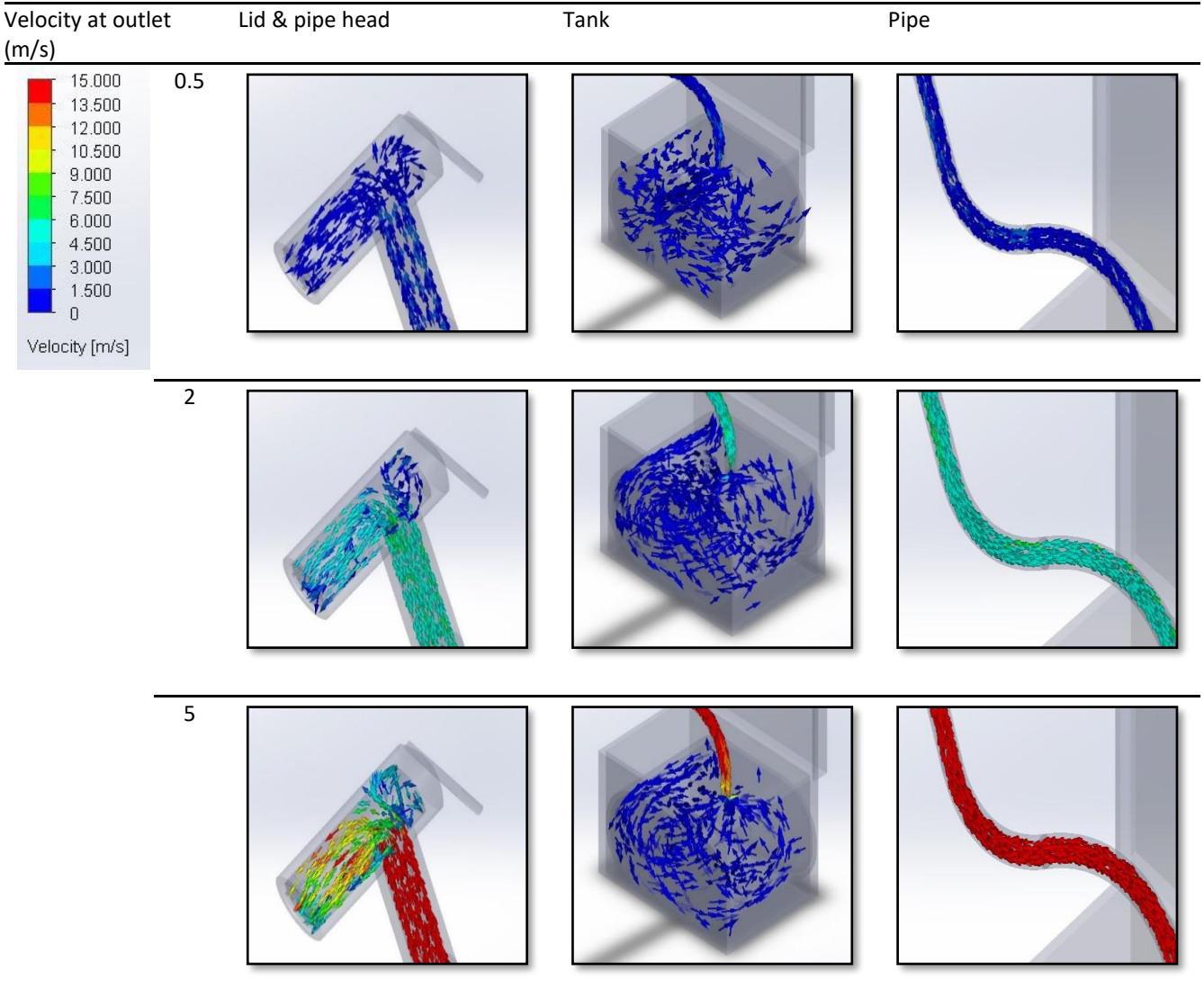

Table 4
 Flow trajectory of the simulation of the water outlet



3.2 Cut Plot

The analysis of flow trajectories within the tank provided valuable insights into the velocity distribution. The findings from the analysis, as presented in Table 3, indicate that different velocity values of 0.5 m/s, 2 m/s, and 5 m/s resulted in distinct flow patterns inside the tank. At a velocity of 0.5 m/s, the flow trajectories inside the tank exhibited velocities at the lower range. This suggests a relatively gentle flow with slower water movement. Note that the velocity distribution appeared uniform throughout the tank, indicating a consistent flow pattern. For a velocity of 2 m/s, the flow trajectories revealed velocities in the middle range. This indicates a moderate flow rate with increased water movement compared to the lower velocity. The velocity distribution showed slight variations across different tank sections, suggesting potential influences from fluid dynamics or obstacles within the system. At the highest velocity of 5 m/s, the flow trajectories showed velocities in the higher range near the tank's inlet. This suggests a more rapid and energetic flow in that vicinity, possibly resulting in turbulent flow patterns. However, as the water dispersed and moved away from the inlet, the velocity decreased and fell within the lower and middle ranges. This can be attributed to the dissipation of energy and the expansion of the flow within the tank.

Similar patterns can be observed by analyzing the flow trajectories presented in Table 4, which corresponds to the water outlet simulation. At a velocity of 0.5 m/s, the flow trajectory at the lid, pipe head, and pipe exhibited velocities within the lower range, indicating a controlled and steady water release through the outlet. For a velocity of 2 m/s, the flow trajectories at the lid, pipe head, and pipe displayed velocities within the middle range. This suggests a moderate flow rate, allowing effective water discharge through the outlet. The velocities observed indicate a balanced flow with efficient water dispersal. On the other hand, at the highest velocity of 5 m/s, the flow trajectories at the lid, pipe head, and pipe exhibited velocities within the higher range. This suggests a more forceful water release through the outlet, potentially providing stronger flushing power or water pressure. However, it is important to note that the velocity within the tank remained within the lower range for all three velocity values, ensuring a stable and controlled environment within the system.

Overall, the analysis of flow trajectories provides valuable information for understanding the velocity distribution within the tank and at the water outlet. These insights contribute to the design's evaluation and optimization, ensuring the system's desired performance and functionality.

Figure 5 and 6 show the water inlet and outlet design models, respectively, with the dimension of the cut plot and velocity range. Table 5 and 6 illustrate flow contour cut plot.

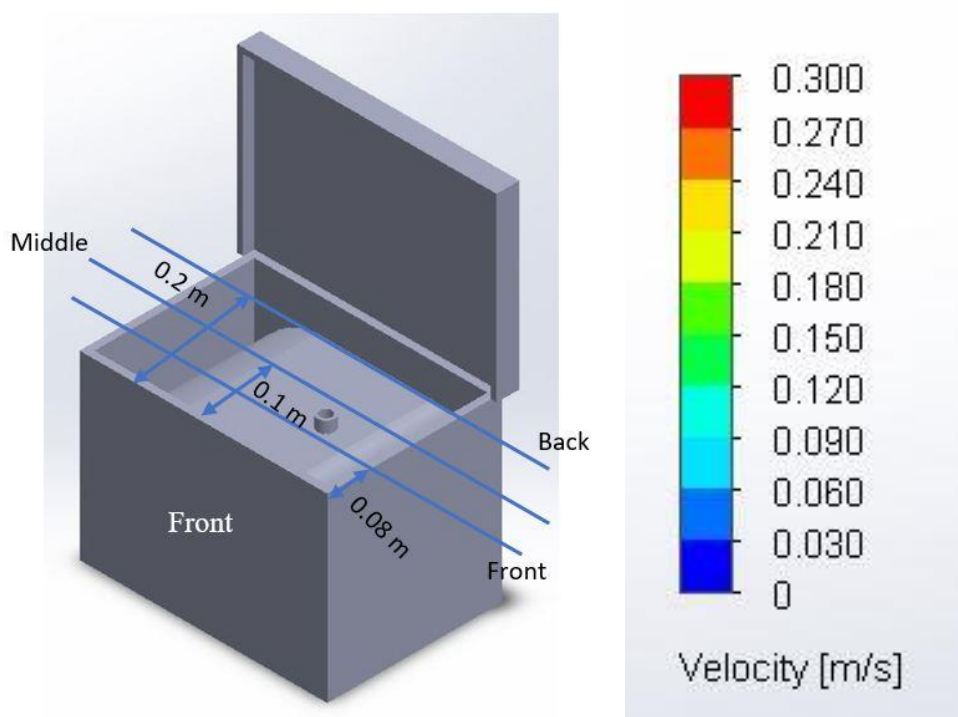
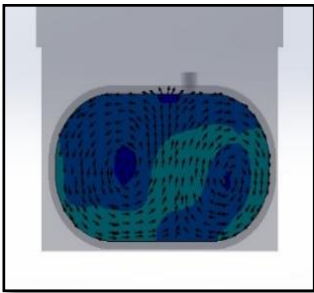
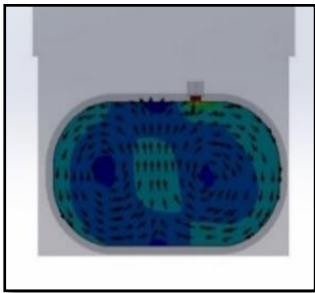
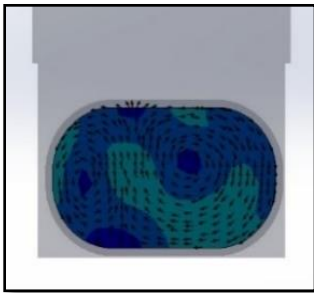
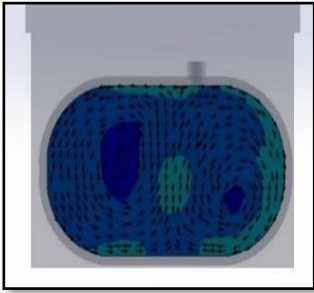
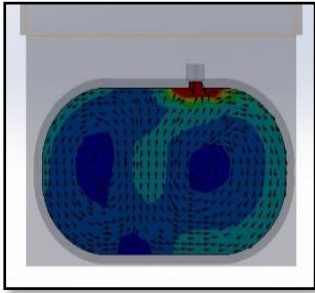
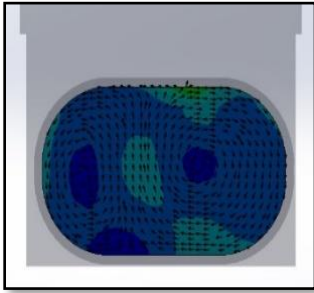
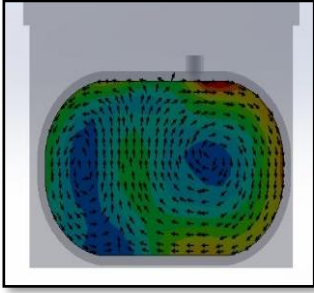
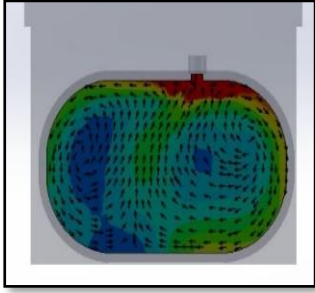
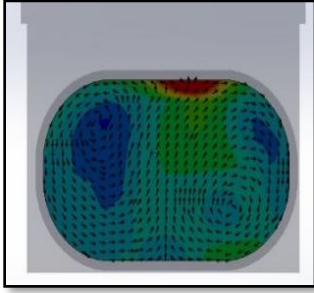

Fig. 5. Water inlet design model with the dimension of the cut plot and velocity range

Table 5
 Flow contour cut plot at the water tank

Velocity at inlet (m/s)	Front	Middle	Back
0.5			
2			
5			

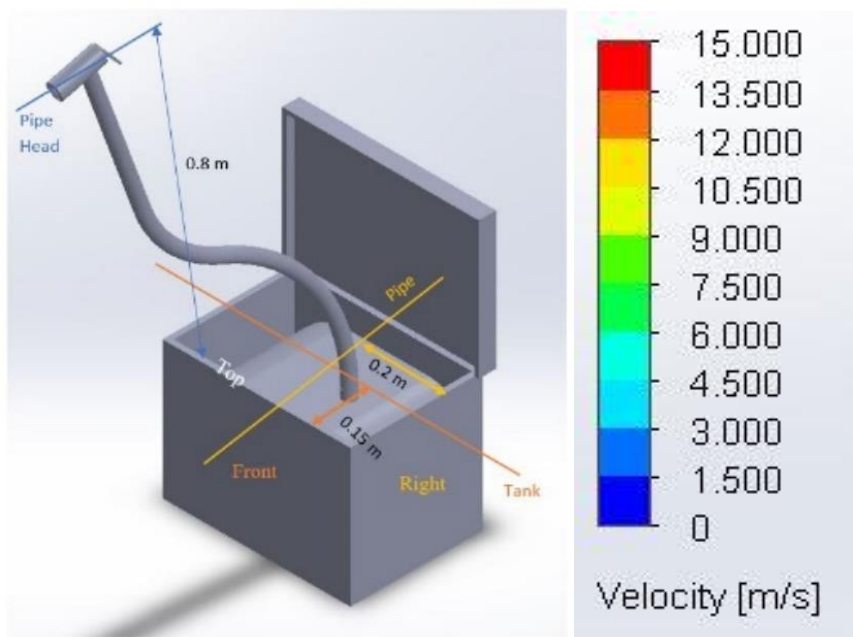
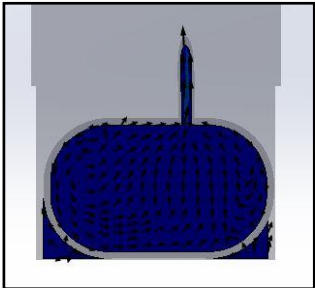
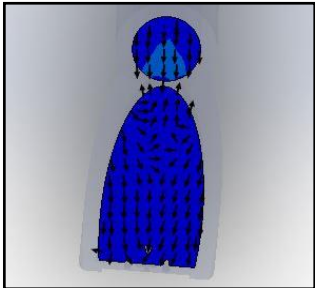

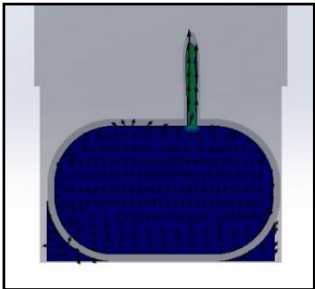
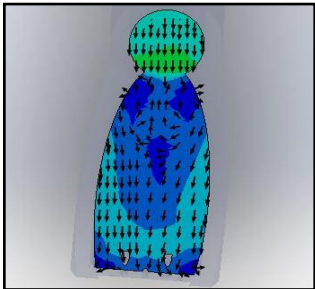
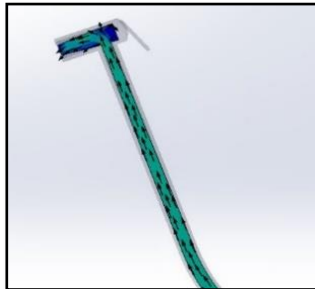
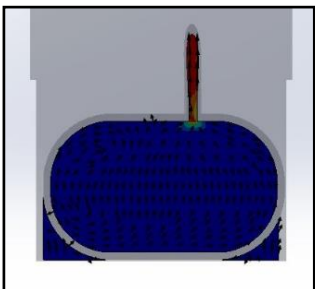
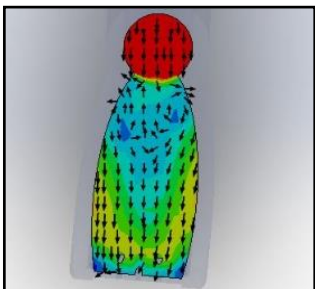
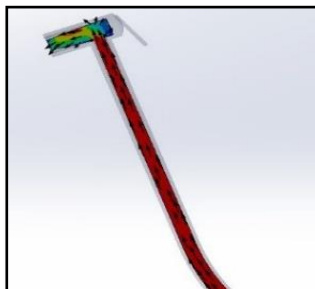

Fig. 6. Water outlet design model with the dimension of the cut plot and velocity range

Table 6
 Flow contour cut plot

Velocity at outlet (m/s)	Front	Middle	Back
0.5			
2			
5			

3.3 Discussion

Throughout the conducted simulation tests, several factors, errors, and uncertainties influenced the results of the model design. One crucial factor that significantly impacted the outcomes was the presence of vortices. Addressing and modifying these vortices could lead to improved output results. Initially, the parameter set for the velocity encompassed values of 0.5 m/s, 2 m/s, and 5 m/s. Note that these distinct values were chosen to facilitate clear differentiation and analysis within the simulation data. In the water inlet simulation, all the obtained results were within the predefined velocity range of 0.5 m/s, 2 m/s, and 5 m/s. This consistency indicates that the design model aligns well with the selected parameters and boundary conditions.

Conversely, errors were observed in the results of the water outlet simulation. The velocities deviated significantly from the designated values of 0.5 m/s, 2 m/s, and 5 m/s. These discrepancies were primarily attributed to the presence of vortices. Figure 7 illustrates the location of the vortex within the simulation. This vortex's occurrence stemmed from the model's design, which did not align effectively with the selected parameter set, boundary conditions, and the desired flow dynamics. Moreover, modifications can be implemented in the design model to mitigate the impact of the vortex. For example, Figure 7 demonstrates the addition of a geometry that can help avoid or

mitigate the vortex. Another approach, as depicted in Figure 8, involves modifying the design model to release the vortex into the pseudo-external environment. By incorporating such modifications, the undesired effects of the vortex on the flow and simulation results can be minimized or eliminated. When analyzing the simulation results, it is important to consider these factors, errors, and uncertainties. By addressing the challenges associated with vortices and optimizing the design model accordingly, more accurate and reliable outcomes can be obtained, leading to improved performance and functionality of the simulated system.

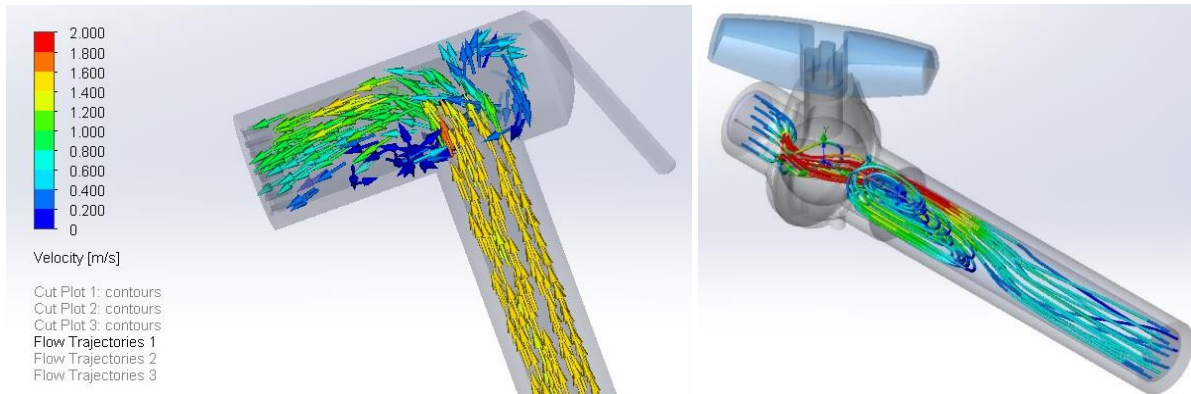

Fig. 7. Location of the vortex in the flow simulation

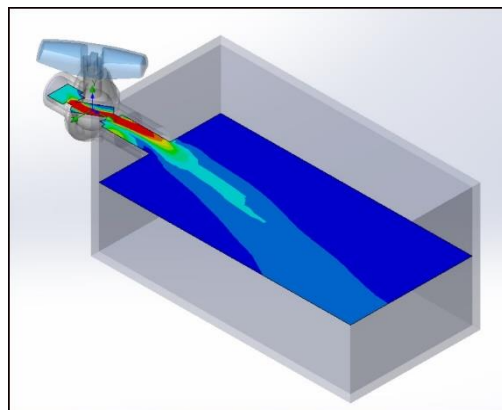

Fig. 8. Release the vortex to the pseudo-external environment

4. Conclusions

The evaluation of concept designs for the easy shower for bedridden patients resulted in Design A being selected as the highest-scoring option. Design A utilized water pressure as its primary mechanism and showcased characteristics such as lightweight, high water capacity, simplicity, ease of handling, ease of use, flexibility, and low production cost. To optimize its performance, modifications were made to align the water inlet and outlet positions to enhance water pressure and minimize pressure loss [27]. The analysis of flow trajectories provided valuable insights into the velocity distribution within the tank and at the water outlet. Furthermore, it revealed distinct flow patterns and velocities for different velocity values, highlighting the stable and controlled environment within the tank and efficient water discharge through the outlet in Design A.

The study's contributions extend beyond the evaluation and optimization of the design. Firstly, it aims to support and assist the bedridden community in their daily routines and personal hygiene, addressing their challenges. The proposed bathing mechanism is a guide or reference for bedridden

patients to manage their daily routine and self-care. Secondly, the study focuses on developing technology that helps minimize energy usage for caregivers attending to bedridden patients, particularly during bed bathing. It recognizes the need for advancements in medical technologies specific to bedridden patients and acknowledges the lack of such developments in certain regions. Overall, the research presented in this study successfully contributes to the bedridden community and caregivers by providing an effective design solution and addressing the unique challenges faced in managing bedridden patients. Hence, optimizing the shower design and considering the flow dynamics ensure convenience, functionality, and efficiency in meeting the needs of bedridden patients and caregivers.

Acknowledgment

This research is supported by the Ministry of Education (MOE) through Fundamental Research Grant Scheme (FRGS/1/2021/FTKMP/F00491) and Universiti Teknikal Malaysia Melaka Short-term Grant (PJP/2020/FTKMP/PP/S01785). The author would like to thank Fakulti Teknologi Kejuruteraan Mekanikal Pembuatan, Universiti Teknikal Malaysia Melaka, for providing feasible research facilities for this study.

References

- [1] Malaysia Population 2020 (Live). (2020). Retrieved from <https://worldpopulationreview.com/countries/malaysia-population/>.
- [2] Onkar, A., & Andhare, A. (2010, November 01). (PDF) Design of a bed for bedridden patient :Design Criteria. https://www.researchgate.net/publication/258926665_Design_of_a_bed_for_bedridden_patient_Design_Criteria
- [3] Bekdemir, Aysun, and Nesrin Ilhan. "Predictors of caregiver burden in caregivers of bedridden patients." *The Journal of Nursing Research* 27, no. 3 (2019): e24. <https://doi.org/10.1097/jnr.000000000000297>
- [4] Bezerra, Karolina, José Machado, Vítor Carvalho, Marcelo Castro, Pedro Costa, Demétrio Matos, and Filomena Soares. "Bath-Ambience—A mechatronic system for assisting the caregivers of bedridden people." *Sensors* 17, no. 5 (2017): 1156. <https://doi.org/10.3390/s17051156>
- [5] Fukuoka, Yumiko, Emi Sasaki, Masako Akiyama, Takuma Satoh, Hisashi Kudo, Reiko Hatakeyama, Masahiko Fujii, and Hidetada Sasaki. "Development of portable shower-tub for bedridden patients." *Geriatrics & gerontology international* 11, no. 2 (2011): 236-238. <https://doi.org/10.1111/j.1447-0594.2010.00677.x>
- [6] Backes, Dirce Stein, Carine Alves Gomes, Simone Barbosa Pereira, Noelucy Ferreira Teles, and Marli Terezinha Stein Backes. "Banheira portátil: tecnologia para o banho de leito em pacientes acamados." *Revista Brasileira de Enfermagem* 70 (2017): 364-369. <https://doi.org/10.1590/0034-7167-2016-0178>
- [7] Downey, Lindsey, and Hilary Lloyd. "Bed bathing patients in hospital." *Nursing standard* 22, no. 34 (2008): 35-40. <https://doi.org/10.7748/ns2008.04.22.34.35.c6531>
- [8] Othman, M. N. K., M. Razlan Zuradzman, D. Hazry, Wan Khairunizam, A. B. Shahrman, S. Yaacob, S. Faiz Ahmed, and Abadalsalam T. Hussain. "Internal air flow analysis of a bladeless micro aerial vehicle hemisphere body using computational fluid dynamic." In *AIP Conference Proceedings*, vol. 1635, no. 1, pp. 182-186. American Institute of Physics, 2014. <https://doi.org/10.1063/1.4903581>
- [9] Suhaimi, Wan Hanif Hazwan Wan, Rosidah Sam, Juliana Johari, and Norlida Buniyamin. "Design and analysis of a gate valve fluid flow using SolidWorks simulation software." In *2014 2nd International Conference on Electrical, Electronics and System Engineering (ICEESE)*, pp. 71-76. IEEE, 2014. <https://doi.org/10.1109/ICEESE.2014.7154597>
- [10] Backes, D. S., Gomes, C. A., Pereira, S. B., Teles, N. F., & Backes, M. T. S. (2017). "Portable bathtub: technology for bed bath in bedridden patients." *Revista Brasileira de Enfermagem*, 70(2017), 364–369. <https://doi.org/10.1590/0034-7167-2016-0178>
- [11] Bekdemir, Aysun, and Nesrin Ilhan. "Predictors of caregiver burden in caregivers of bedridden patients." *The Journal of Nursing Research* 27, no. 3 (2019): e24. <https://doi.org/10.1097/jnr.000000000000297>
- [12] Bezerra, Karolina, José Machado, Vítor Carvalho, Marcelo Castro, Pedro Costa, Demétrio Matos, and Filomena Soares. "Bath-Ambience—A mechatronic system for assisting the caregivers of bedridden people." *Sensors* 17, no. 5 (2017): 1156. <https://doi.org/10.3390/s17051156>
- [13] Downey, Lindsey, and Hilary Lloyd. "Bed bathing patients in hospital." *Nursing standard* 22, no. 34 (2008): 35-40. <https://doi.org/10.7748/ns2008.04.22.34.35.c6531>

- [14] Fukuoka, Yumiko, Emi Sasaki, Masako Akiyama, Takuma Satoh, Hisashi Kudo, Reiko Hatakeyama, Masahiko Fujii, and Hidetada Sasaki. "Development of portable shower-tub for bedridden patients." *Geriatrics & gerontology international* 11, no. 2 (2011): 236-238. <https://doi.org/10.1111/j.1447-0594.2010.00677.x>
- [15] Othman, M. N. K., M. Razlan Zuradzman, D. Hazry, Wan Khairunizam, A. B. Shahriman, S. Yaacob, S. Faiz Ahmed, and Abadalsalam T. Hussain. "Internal air flow analysis of a bladeless micro aerial vehicle hemisphere body using computational fluid dynamic." In *AIP Conference Proceedings*, vol. 1635, no. 1, pp. 182-186. American Institute of Physics, 2014. <https://doi.org/10.1063/1.4903581>
- [16] Suhaimi, Wan Hanif Hazwan Wan, Rosidah Sam, Juliana Johari, and Norlida Buniyamin. "Design and analysis of a gate valve fluid flow using SolidWorks simulation software." In *2014 2nd International Conference on Electrical, Electronics and System Engineering (ICEESE)*, pp. 71-76. IEEE, 2014. <https://doi.org/10.1109/ICEESE.2014.7154597>
- [17] Malaysia Population 2020 (Live). (2020).
- [18] Onkar, A., & Andhare, A. (2010, November 01). (PDF) Design of a bed for bedridden patient :Design Criteria. Retrieved June 23, 2020.
- [19] Rodriguez, A. (2018, December 10). The Difference Between 5/8-Inch and 3/4-Inch Garden Hose. Retrieved June 23, 2020.
- [20] Boley, A. (2019, March 02). How to Calculate Water Flow Through a Pipe Based on Pressure. Retrieved June 23, 2020.
- [21] Conversion Gallon per minute(US) to Cubic meter per second. (n.d.). Retrieved June 23, 2020.
- [22] Wong, Ling-tim, Kwok-wai Mui, and Yang Zhou. "Impact evaluation of low flow showerheads for Hong Kong residents." *Water* 8, no. 7 (2016): 305. <https://doi.org/10.3390/w8070305>
- [23] Okamoto, M.; Sato, M.; Yamazaki, H.; Shodai, Y.; Cheng, C.L.; Sakaue, K. Study on relationship between the subjective shower-feeling and the criteria for low-flow showerhead. In *Proceedings of the 39th International Symposium of CIBW062 Water Supply and Drainage for Buildings, Nagano, Japan, 17-20 September 2013*; pp. 645-655. <https://doi.org/10.3390/w8070305>
- [24] Okamoto, Minami, Ryohei Yaita, Minoru Sato, Masayoshi Kamijo, Kanako Toyosada, Yasutoshi Shimizu, Kyosuke Sakaue, Wan-Ju Liao, Meng-Chieh Lee, and Cheng-Li Cheng. "Comparison of the physical properties of showers that the satisfaction of shower feeling among users in three asian countries." *Water* 7, no. 8 (2015): 4161-4174. <https://doi.org/10.3390/w7084161>
- [25] Toyosada, K., T. Otani, Y. Shimizu, and A. Yonemaru. "Research on the effect of showerhead characteristics on usage time and hot water volume." In *Proceedings of the 39th International Symposium of CIBW062 Water Supply and Drainage for Buildings, Nagano, Japan*, pp. 17-20. 2013.
- [26] Makki, Anas A., Rodney A. Stewart, Kriengsak Panuwatwanich, and Cara Beal. "Revealing the determinants of shower water end use consumption: enabling better targeted urban water conservation strategies." *Journal of Cleaner Production* 60 (2013): 129-146. <https://doi.org/10.1016/j.jclepro.2011.08.007>
- [27] Anwar, Rama Putrantyo, Sri Sundari, and Mochamad Syamsiro. "Computational Fluid Dynamics of Two-Phase Flow Pressure Gradient of Air-Sodium Chloride and Glucose in Horizontal Capillary Channels." *CFD Letters* 14, no. 1 (2022): 52-65. <https://doi.org/10.37934/cfdl.14.1.5265>