



# Journal of Advanced Research in Applied Mechanics

Journal homepage:  
[https://semarakilmu.com.my/journals/index.php/appl\\_mech/index](https://semarakilmu.com.my/journals/index.php/appl_mech/index)  
ISSN: 2289-7895



## Analysis of Variable Frequency Drive for Induction Motor using Matlab Software

Muhammad Zikri Hamim<sup>1</sup>, Suriana Salimin<sup>1,\*</sup>, Afarulrazi Abu Bakar<sup>1</sup>

<sup>1</sup> Department of Electrical Engineering, Faculty of Electrical and Electronic Engineering, Universiti Tun Hussein Onn Malaysia, 86400 Parit Raja, Batu Pahat, Johor, Malaysia

### ARTICLE INFO

#### Article history:

Received 6 January 2024

Received in revised form 3 March 2024

Accepted 17 March 2024

Available online 30 April 2024

#### Keywords:

Variable frequency drive; inverter; simulation

### ABSTRACT

Induction motors have become essential part in motor-driven machinery industries. However, the inability to regulate the speed of the load can present significant challenges in terms of machinery maintenance and energy consumption. This paper simulates and proposes a solution for the induction motor speed control which implements an inverter consisting of a Variable Frequency Drive (VFD) system using Matlab software. The aim is to analyze the impact of adding a VFD circuit to a three-phase motor system in terms of its starting current and speed. A VFD is highly beneficial for electric motors as it can optimize motor speed based on the specific requirements or desired speed settings. The method involves the uses of power electronic devices such as IGBT components. By controlling the duration of on-off time and the width of the pulse, a desired frequency can be obtained. By varying the frequency of the power supply to the motor, the synchronous speed can be controlled to the required value. Simulation results demonstrate that a circuit with a variable frequency drive (VFD) drastically reduces starting current, effectively minimizing power losses during motor start-up. Comparative analysis reveals that the VFD, the starting current surge to approximately 9A, a significant improvement compared to the 50A spike observed without the VFD. Additionally, the motor speed remains consistent in both scenarios, suggesting that the VFD does not adversely affect the motor's speed, which is 1490 rpm, while maintaining the voltage and current supplied to the load. The findings highlight the benefits of using a VFD in the motor system to improve energy efficiency and minimize power losses during operation.

## 1. Introduction

Nowadays, electric motor or induction motor are commonly used in most industry. Its low sensitivity to disturbances during operation make the squirrel cage the first option when selecting a motor for a particular application [1]. Due to the induction motor's wide range of industrial uses, there has been a lot of study done to improve its technological capabilities, and firms from around the world have embraced this business [2]. This is due to their high and continual energy consumption, as they are facilities with substantial energy needs [3]. Without the ability to control

\* Corresponding Author.

E-mail address: [suriana@uthm.edu.my](mailto:suriana@uthm.edu.my)

<https://doi.org/10.37934/aram.116.1.117129>

the speed of load, it can be quite hard for maintaining the machine and its energy consumption. Plus, in situations where high velocities are maintained during stable operation, various benefits in terms of energy conservation can be effectively realized, presenting the opportunity for substantial energy savings in specific applications [4]. Therefore, it is crucial to take advantage of any chance to reduce the amount of electricity used by electric motors, particularly in light of the global focus on energy efficiency and green technology [5].

Most of the motors used are induction motors and one way of reducing induction motors' power consumption is through the introduction of power electronics controller to control the speed of electric motor. Given that the electronics controller or VFD are widely used in AC motor-driven applications, such as variable frequency drive for motor control, so it is crucial to understand how they operate [6]. Figure 1 illustrates the block diagram of the VFD. This device is commonly used to regulate the speed of conveyor systems, blowers, pumps, machines, and other applications that required variable speed and variable torque [7].

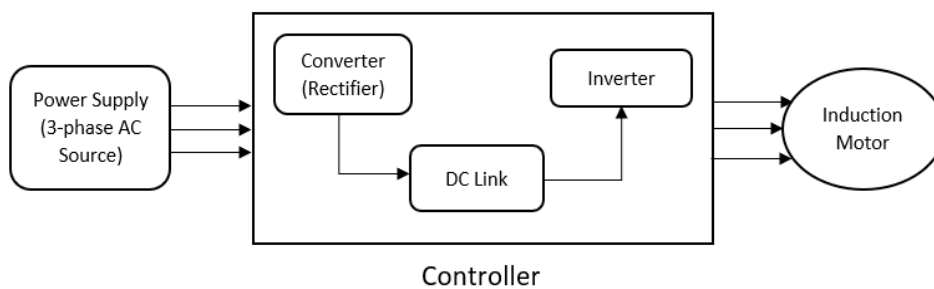

**Fig. 1.** Block Diagram for Variable Frequency Drive

VFD is very useful for electric motor as it is able to optimize motor speed depending on the need or desired speed value. As for example, the advanced direct current (DC) inverter technology used to drive the compressor's highly efficient DC motor and provide a larger output power range makes the inverter air conditioner more energy-efficient hence this will result in higher power and more energy savings [8]. Usually, induction motor consumes more electricity than required. The motor uses a lot of energy whenever the torque or velocity varies, especially when the motor is starting up or when more torque is needed [9]. This is called overshooting current and usually occurred during start up process of a motor. This is because when induction motor connected directly to the grid, the motor exhibits significant initial torque pulsation and high inrush current [10]. These phenomena will lead to high wattage consumption and next effect the bill costing. Furthermore, operating motors at speeds higher than required not only leads to energy wastage but also often leads to premature motor deterioration, raising maintenance expenses and potentially diminishing the motors' lifespan.

A VFD main function is to change an AC supply operating frequency. In other words, it transforms AC into DC and then back into AC with adjustable frequency, however the process is quite complex as it requires four VFD blocks. These blocks are the Control Unit Section, Inverter Section, DC Bus/Filter Section, and Converter (rectifier) Section as shown in Figure 2.

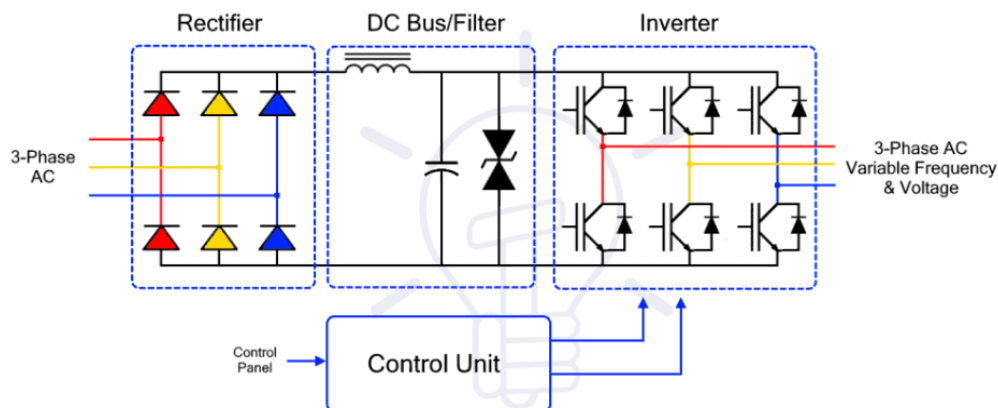

**Fig. 2.** Detail block diagram of Variable Frequency Drive (VFD) [9]

For VFD initial section, rectifier was used. It is constructed from 6 or 4 diodes which are for three-phase and single-phase conversion respectively. Half of them were on forward bias while the remaining were on reverse bias. It does this by using electrical components that can turn on and off, such as IGBT, GTO, and MOSFET [11]. The rectifier converts the sinusoidal input into a pulsating DC that swings between the maximum positive peak and zero volts. Next, in DC link section, the DC power that the inverter extracts are filtered and stored. The primary purpose of filters is to eliminate ripples from the rectifier's pulsing DC output. If the ripple exceeds the specified value, different unwanted effects appear in the system and some of the unwanted effects are stray heating, audible noise [12]. Then is the switching or inverter part that changes the constant DC into adjustable-frequency alternating AC. It varies the output frequency to control the speed of the induction motor using modulation techniques like PWM method. PWM control involves quickly turning on and off the IGBT switches so that a varied waveform is created by pulses of varying widths. Lastly, the control unit oversees and regulates the rectifier, intermediate circuit, and inverter to ensure that the correct output is produced in response to external control signals. After considering the input command and sensor inputs, the controller gives the power converter the reference signal to inform it of the amount of power it needs to create [13-15].

Gurle *et al.*, [16] have studied speed control of three phase induction motors by stator voltage. It was stated that for an induction motor, if the applied voltage is reduced while maintaining a fixed frequency at a certain load, the air gap flux will also decrease. As a result, the torque or power generated is reduced. As the rotor speed drops, the amount of slip increases, increasing the torque needed to balance the load torque. As a result, changes in voltage also affect the motor's ability to manage speed and slip frequency. The rotor should have a high resistance for speed control across a considerable range. This method is suited for fan and pump drives as well as situations where the drive must operate intermittently. Research has also been studied on electric drive control with rotor resistance by Regaya *et al.*, [17]. The paper focused on controlling the motor speed rotor resistance method. For this method, maximum torque is independent of rotor resistance but the slip that occurs is directly proportional to the rotor resistance. Using the same torque, speed falls when there are increase in rotor resistance which can become the controller for the motor. A suitable value of rotor resistance can overcome the problem by implementing fuzzy logic into the system. For the project, a model reference adaptive system (MRAS) that is a based observer has been proposed which use the voltage model and current model for sensorless control of induction motor drive.

G. D. Andreescu [18] has focused on how pole changing permanent magnet (PM) motor can be built for few reasons and one of the reasons is for speed controlling. A PM or memory motor can be

built as a variable-flux or pole-changing device as it has an ability to change the magnetization of its magnets with low amount of stator current. In the studies, pole changing PM machine delivers more power at higher efficiency, generate lower heat as the rotor lack losses than in the squirrel-cage machine [19,20]. On the other research studied by Ejiofor *et al.*, [21], slip power is varies to yield the adjustable speed drive system. The slip energy recovery scheme is done by using electronic based converter technique. The power recovery and energy saving are got from the switching devices component control which is thyristor. The system is a bit similar to the variable speed drive with the implement of converter and inverter. With the help of static converters, slip power can be recovered rather than being lost in the resistance. There is associated harmonic injection on the source side as a result of the converter and line commutated inverter.

In another study by Ozan *et al.*, [22], predictive torque and flux control methods are introduced for two induction machines powered by a dual-output indirect matrix converter. The paper underscores the utilization of mathematical models for predicting control objectives, the selection of optimal switching combinations through a multi-objective cost function, and the reduction of torque and flux errors. In a subsequent work by the same author [23], the research extends to the control of multiple induction motors using dual-hysteresis torque control powered by a nine-switch inverter. This method efficiently manages two distinct induction motors with tailored mechanical references, employing stator current, mechanical speed, and torque as control variables.

Additionally, the Nine-Switch Inverter (NSI) is proposed as an alternative to traditional two-level three-phase voltage source inverters (VSIs) for handling multiple loads [24]. While typical VSIs increase system costs and volume due to additional discrete components, the implementation of the NSI offers an equally efficient solution with fewer semiconductor switches, thereby reducing overall system costs and volume. These prior studies primarily focused on achieving independent control of multiple loads, albeit with the recognition of the need for integration in more complex systems.

Current studies acknowledge challenges in the energy efficiency of electric motors, specifically induction motors, prompting the adoption of power electronics controllers like Variable Frequency Drives (VFDs). However, there is a lack of detailed understanding regarding the operation and impact of VFDs, particularly in controlling induction motor speed. This research aims to fill this gap by thoroughly examining how VFDs work and their role in optimizing induction motor speed. The study also investigates the efficiency of VFDs in reducing energy wastage during motor start-up, providing valuable insights for enhancing energy efficiency in motor-driven systems. As for this paper, it proposes a solution for the induction motor speed controller, implementing a simpler yet efficient inverter with a VFD system. This system is designed to reduce motor starting current overshoot, leading to a decrease in power loss. The method involves power electronic devices, such as IGBT components, to control on-off time and pulse width, achieving a desired frequency with optimized output. The comparison between implementing VFD and without VFD will be highlighted to observe differences.

## 2. Methodology

To achieve the aim of this paper, two circuit models of the system are designed using MATLAB software. Through the simulation, many parameters can be observed such as the graph of input voltage, output voltage and output current. With this information, the load voltage, current, and speed are figured out. An induction motor is also connected to the load to test whether the circuit design is functioning correctly. Next subsection explained more details on the development of the circuit design.

## 2.1 Simulation Design

The design of the circuit is a three-phase variable frequency drive which the concept is taken from the back-back converter shown in Figure 3. The back-to-back converter mainly consists of two sections which are rectifier and inverter. However, in this project, it will focus mainly on the inverter part to drive the asynchronous motor and is focusing on the frequency converter system and control the speed motor speed by changing the frequency manually.

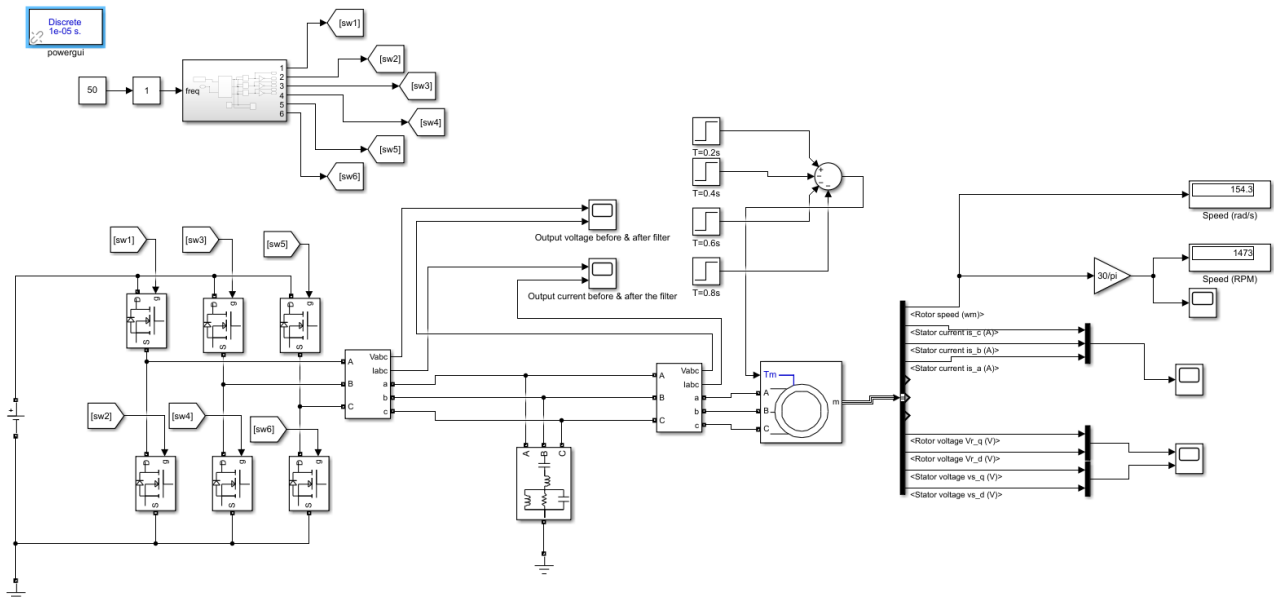

**Fig. 3.** Simulation of motor with three-phase variable frequency drive

The various drawbacks of the variable speed drive, such as its low efficiency, unpredictable speed control, and substantial space requirements, have gradually been solved thanks to advancements in power electronics [25,26]. Now, with the switching of the IGBT components can determine the amount of the energy consumed to the load which was the motor. The value of frequency where it can be varied manually will determine the amount of modulated width size in the switching graph pattern accordingly. Difference value of frequency would give different switching width modulation hence controlling the speed of the motor. This can be set manually through the slider gain block that is connected to the PWM subsection (top left block) which will then give command to the IGBT component on the inverter side. In this case, 50 Hz value used to be compared with the other simulation.

Next, on the simulation without the VFD, the connection circuit is as shown on Figure 4.

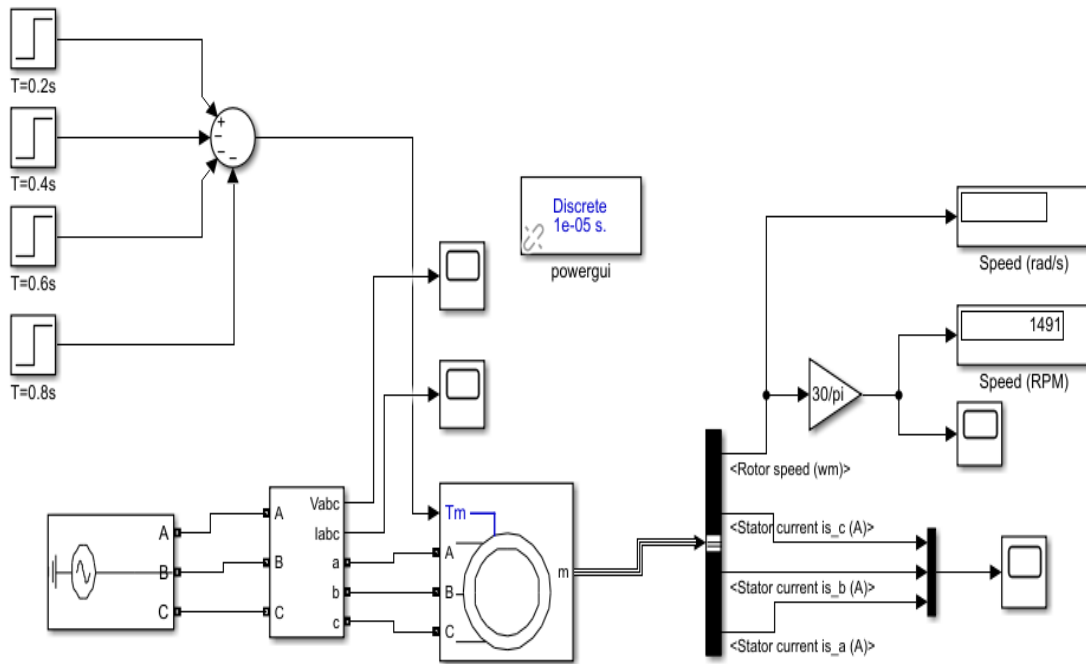

**Fig. 4.** Simulation of motor without variable frequency drive

The motor would be energized solely through the three phase power supply alone. The absence of an inverter part makes the circuit look simple but the induction motor still can run normally but with different output indications that would be discussed in more detail in the discussion. Without the VFD, the normal operating frequency of the supply will be based on standard rating which is 50 Hz value. These two circuits with different integration will be simulated on the MATLAB software and various outputs will then be analysed and compared between the two conditions.

The Powergui block serves as a central tool for managing and configuring power system simulations. In this project, the Powergui settings, depicted in Figure 5, outline the specifics of the simulation setup. A discrete simulation with a sampling period set at 0.1 microseconds and the Tustin/Backward Euler (TBE) solver was selected for this particular project.

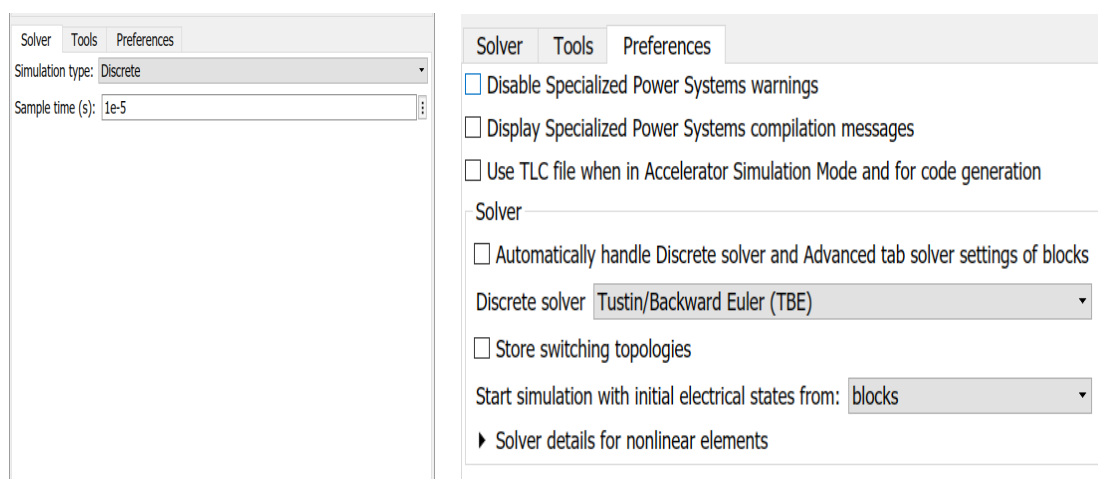

**Fig. 5.** MATLAB Power System Simulation

## 2.2 Parameters of Motor Load

This part describes the design parameters of the induction motor used in the MATLAB software. The component used in the software that resembles the squirrel cage induction motor is Asynchronous Machine (SI units) as shown in Figure 6 whilst the chosen induction motor of squirrel cage type specifications is shown in Table 1.

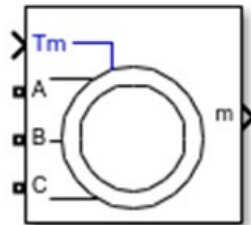

**Fig. 6.** Asynchronous machine

**Table 1**  
 Specifications of squirrel cage of induction motor

Specification	Value
Horsepower	5.4 Hp
Power	4 kW
Voltage	400 V
Frequency	50 Hz
Speed	1430 rpm

## 2.3 Conditions for Motor Load

In this simulation, various conditions were introduced by systematically varying the mechanical torque applied to the motor. As a result, distinct outputs were observed for each applied condition. The specified conditions were as follows as in Table 2.

**Table 2**  
 Specifications of squirrel cage of induction motor

Sampling Time (second)	Torque Value (Nm)
0.2	26.8452
0.4	13.4226
0.6	6.7113
0.8	3.3556

As depicted in Table 2, at a sampling time of 0.2 seconds, the torque reached its maximum value, signifying that the motor was operating under full load conditions. Subsequently, at 0.4 seconds, the torque was halved, indicating a departure from the full load state. This halving trend persisted at 0.6 seconds and 0.8 seconds, respectively.

## 3. Results and Discussion

### 3.1 Simulation Results between Condition with VFD (Inverter) and Condition without VFD

Figure 7 and Figure 8 shows the waveform comparison for output voltage of DC-AC converter (Inverter) and without the inverter. In Figure 7, the above waveform indicates the output voltage of

inverter without a filtering circuit while the below waveform indicates the output voltage of inverter with addition of filter.

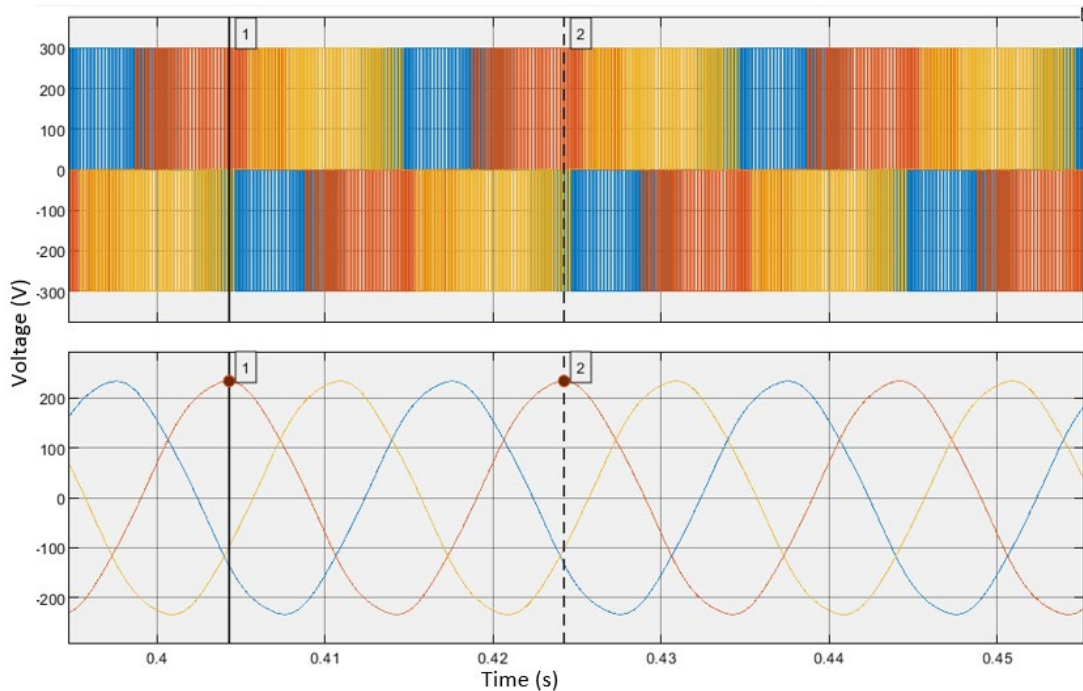

**Fig. 7.** Output Voltage of Inverter (with VFD) before and after filtering

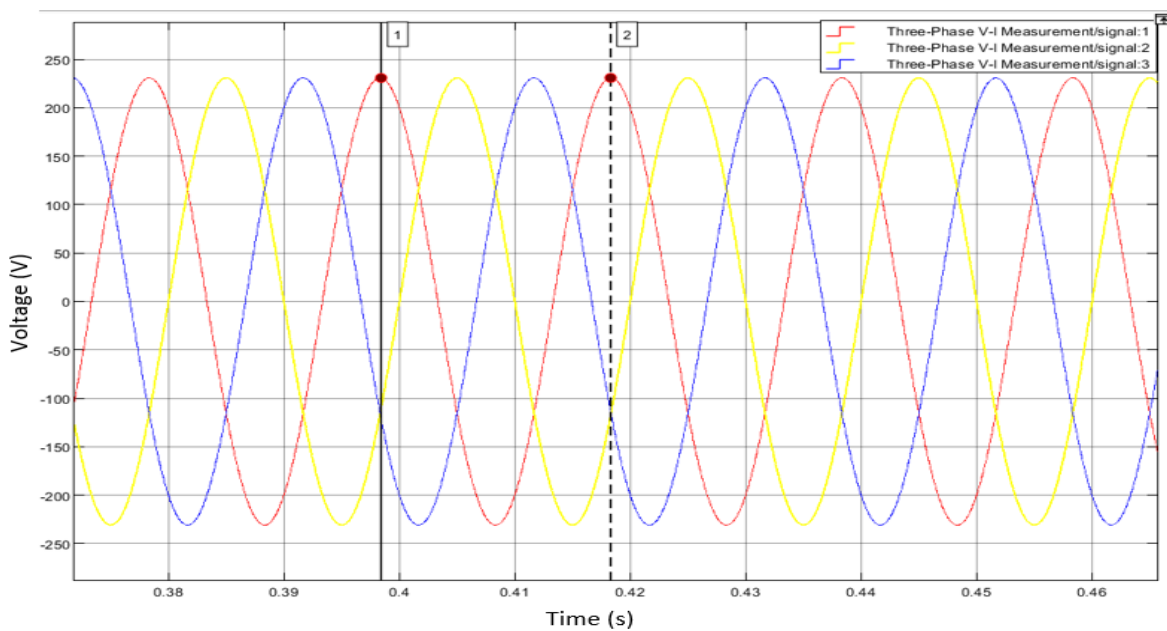

**Fig. 8.** Output Voltage without VFD

The role of an IGBT in an inverter is to function as a switch, activated by applying a signal to the gate for turning on and turned off by removing the signal. This transition is governed by the switching frequency of the Pulse Width Modulation (PWM) rate. The resulting switching process generates a pulse train, which, upon passing through the LC output filter at the junction of the ideal switch, capacitor, and inductor, produces an outgoing AC voltage. Upon examination of the figures, it is evident that the filtered voltage value ( $V_{max}$ ) is approximately 230 V. Figure 8 illustrates the



output voltage directly from the source without the implementation of a Variable Frequency Drive (VFD). In this case as well, the voltage value ( $V_{max}$ ) remains around 230 V.

Figures 9 and 10 below illustrate the output current results of the DC-AC converter with and without the converter, respectively. The current values are responsive to the torque applied, as outlined in the methodology detailing conditions for motor load. During the full load condition of the motor (from 0.2s to 0.4s), the current peaks at approximately 20 A in Figure 9 and around 17 A in Figure 10. Subsequently, the current gradually decreases to half of the full load value at 0.4s follow at 0.6s and 0.8s, reflecting the variations in mechanical torque.

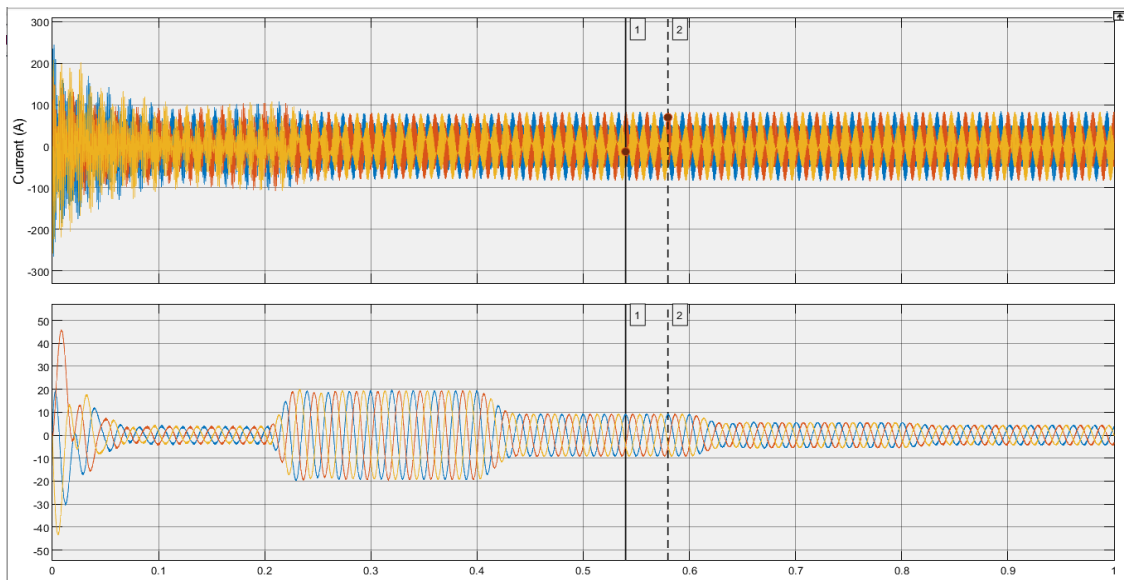

**Fig. 9.** Output Current of Inverter (with VFD) before and after filtering

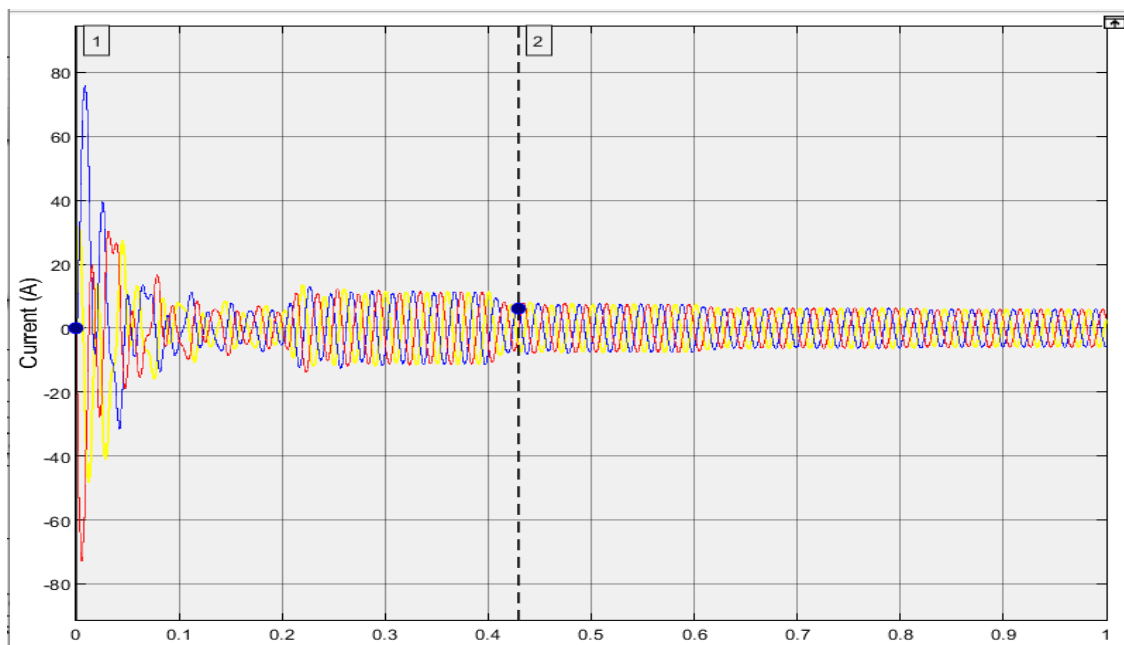
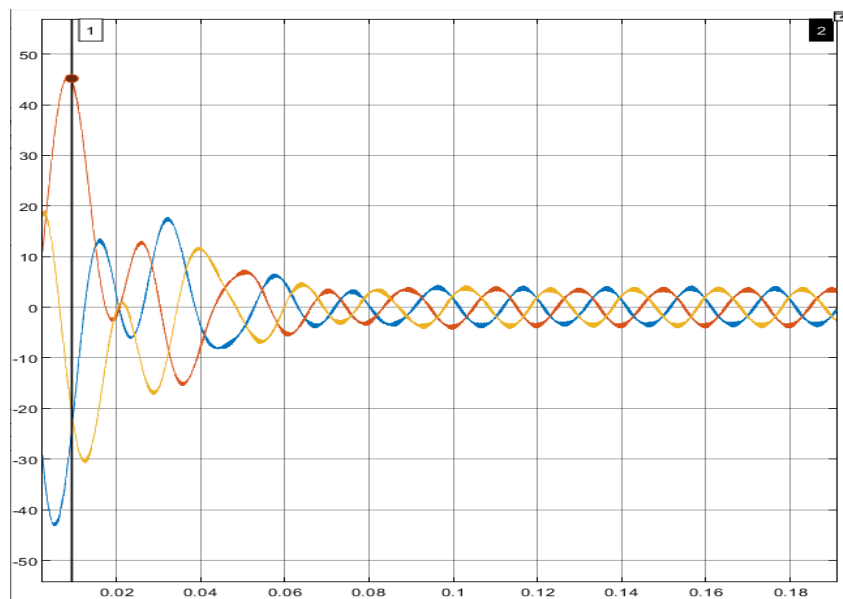

**Fig. 10.** Output Current without VFD

Analyzing the outcomes, it becomes evident that under dynamic load conditions, specifically, the variation of mechanical torque in this simulation produce a clear correlation. It can be

concluded that as the mechanical torque increases (indicating a higher load applied to the motor), there is a corresponding rise in the required current for motor operation.

Figure 11 and 12 illustrates the starting current for both simulations of the motor with and without the VFD respectively. From the graph, it can be seen clearly that starting current without VFD were surging significantly up until more than 70 A compared to average current was 4 A. The starting was about 14 times the average current and this value is considered a very high value which will cost a lot of power losses. While in the simulation with the VFD show the starting current spiking around 40 A compared to average which is 5 A. The starting just around 8 times higher than average current. There was significant different between the implementation of VFD and without it where this show that with VFD, it can reduce power losses in the system.



**Fig. 11.** Starting Current of motor with VFD

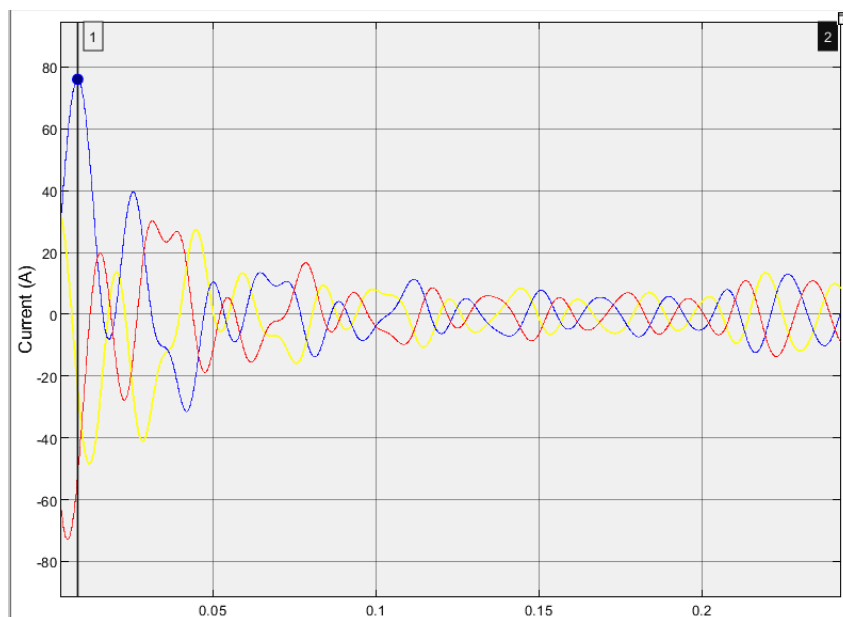

**Fig. 12.** Starting Current of motor without VFD

Figure 13 and figure 14 shows the current and voltage Total Harmonic Distortion (THD) when we implement the VFD which were from Fast Fourier Transform (FFT) Analyzer in the MATLAB

feature. THD is a measurement that tells you how much of the distortion of a voltage or current is due to harmonics in the signal. It is always expressed as a percentage and represents the ratio of the sum of the powers of all harmonic components to the power of the fundamental frequency. As it can be seen in Figure 13, the current THD is around 17.22% while voltage THD in Figure 14 is around 2.09% which is acceptable. So, the value gain from the simulation were acceptable and consider low as for distortion noise.

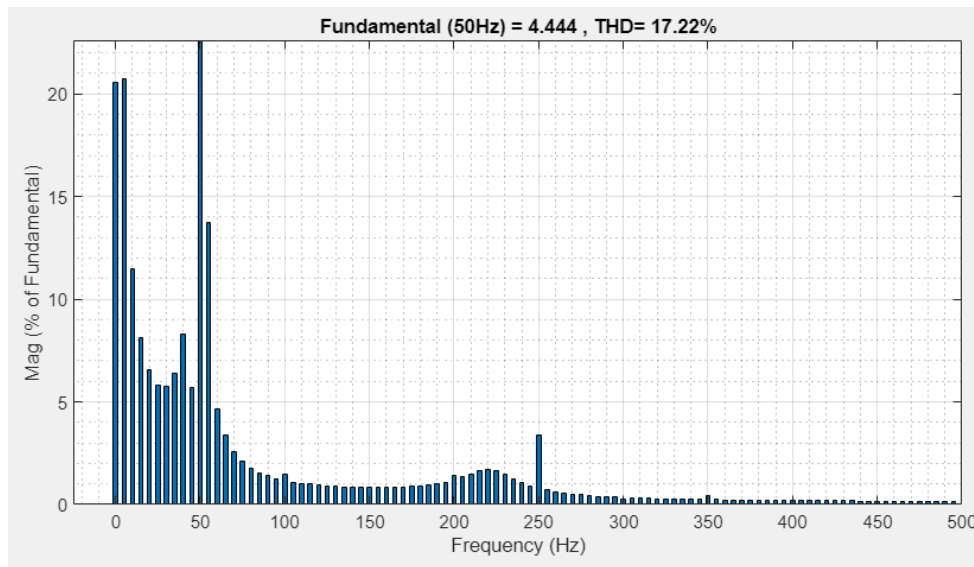

Fig. 13. Current THD with implementation of VFD

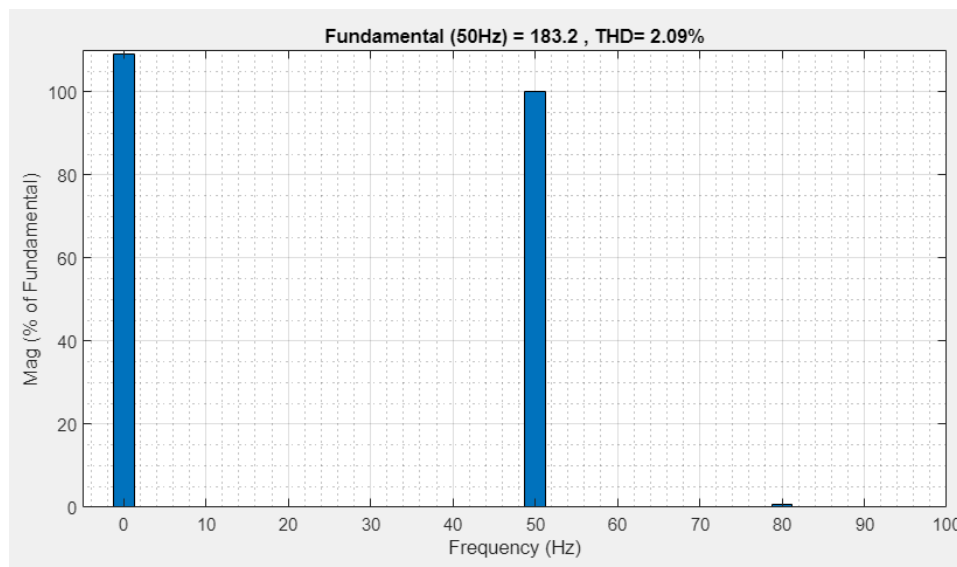
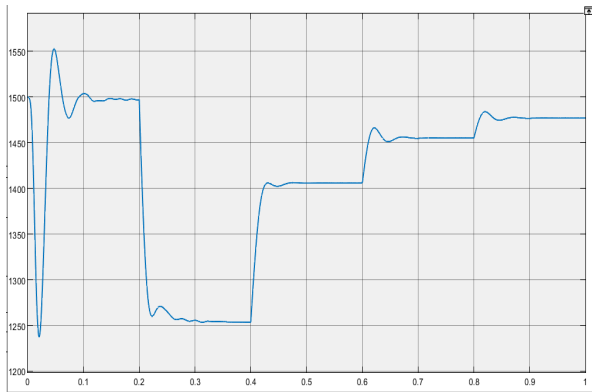

Fig. 14. Voltage THD with implementation of VFD

### 3.2 Results for Load (Motor) Speed with Two Different Conditions

In Figures 15 and 16, the speed variations of a three-phase asynchronous machine are depicted under two distinct conditions: one with the application of a Variable Frequency Drive (VFD) and the other without it. A noticeable disparity in both waveform and speed values is observed between the two simulations, influenced by the varying load conditions imposed by mechanical torque. Figure 15 exhibits a more significance change in speed as the load is varied compared to Figure 16.

Despite the substantial difference, it's noticeable that at the free-load condition at 0.8s onwards, the speed values converge, remaining approximately the same at around 1480 rpm.



**Fig. 15.** Motor Speed with the implementation of VFD

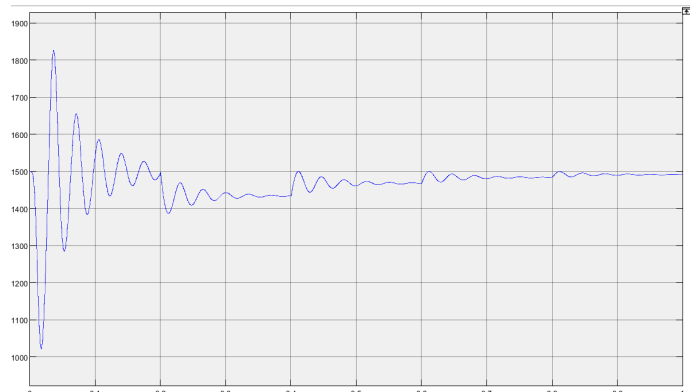

**Fig. 16.** Motor Speed without the implementation of VFD

#### 4. Conclusions

In conclusion, this paper has simulated and proposed a solution for the induction motor speed controller by implementing the inverter that consists of Variable Frequency Drive (VFD) system using MATLAB software. The simulation shows that using the VFD significantly reduces the beginning current. Starting current spikes with a VFD are capped at about 40 A as opposed to more than 70 A without one. This can lead to minimizing the power losses during motor start-up which will improve energy efficiency. There are significance changes in graph when motor load varied, but regardless of when the motor in free load condition whether VFD presence or absence, the motor speed stays around the same value which in these cases the speed remains at 1480 rpm value. This demonstrates how the VFD can control motor speed without sacrificing load-bearing capacity. This research emphasizes how motor-driven systems have been transformed by VFD technology. IGBTs and PWM techniques are used by VFDs to offer precise speed control and starting current reduction, which may lead to large energy savings, less power losses, and improved operational efficiency.

#### Acknowledgement

The author would like to express their gratitude to Universiti Tun Hussein Onn Malaysia (UTHM) for sponsoring this paper publication.

#### References

- [1] Yamano, M., K. Katayama, and Y. Okamoto. "Sensitivity-based topology optimization of squirrel-cage induction motor in time domain using multi-material level-set method." *IEEE Transactions on Magnetics* 58, no. 9 (2022): 1-4. <https://10.1109/TMAG.2022.3179876>
- [2] Ping, Law Jeffrey Mark Tze. "Fuzzy logic speed controller of an induction motor." *Thesis, PTTA Digital Archive, Universiti Tun Hussein Onn* (2018): 1-64.
- [3] Noranai, Zamri, Nurul Farahin Mohd Joharudin, Noradila Abdul Latif, Nur Liyana'Amirah Mohd Kamil, and Mohd Azahari Razali. "A Case Study on Potential Saving of Energy Consumption at Hospital Putrajaya." *Journal of Advanced Research in Fluid Mechanics and Thermal Sciences* 100, no. 2 (2022): 15-22. <https://doi.org/10.37934/arfmts.100.2.1522>
- [4] Salam, Syed Munimus, and Muhammad Mahbubur Rashid. "Performance Analysis of a Designed Prototype of a Motor Coupled Variable Inertia Flywheel System." *Malaysian Journal on Composites Science and Manufacturing* 12, no. 1 (2023): 62-72. <https://doi.org/10.37934/mjcs.12.1.6272>

- [5] Lee, Teng Hong. "VARIABLE SPEED DRIVE FOR THREE-PHASE INDUCTION MOTOR IN COOLING APPLICATIONS." PhD diss., Universiti Teknologi Petronas, 2010.
- [6] Ahmad, Israr. "Working Principle of Variable Frequency Drive (VFD) ". *Pakistan Forum* 4 (2021): 1-4.
- [7] KIFFLI, NORINA BINTI. "SINGLE PHASE TO THREE PHASE CONVERTER FOR VARIABLE SPEED DRIVE APPLICATIONS." *Thesis, UTPedia, Universiti Teknologi Petronas* (2012): 1-58.
- [8] Sukri, Mohamad, and M. K. Jamali. "Economics analysis of an inverter and non-inverter type split unit air-conditioners for household application." *ARPN J. Eng. Appl. Sci* 13 (2018): 3749-3757.
- [9] Resa, Jorge, Domingo Cortes, Juan Francisco Marquez-Rubio, and David Navarro. "Reduction of induction motor energy consumption via variable velocity and flux references." *Electronics* 8, no. 7 (2019): 740. <http://dx.doi.org/10.3390/electronics8070740>.
- [10] Shabestari, Parisa M., and Ali Mehrizi-Sani. "Current limiting and torque pulsation reduction of the induction motors." In *2019 IEEE Power & Energy Society General Meeting (PESGM)*, pp. 1-5. IEEE, 2019. <http://dx.doi.org/10.1109/PESGM40551.2019.8973904>.
- [11] Todorov, George, and Dimitar Jetchev. "Start-up process of Induction motor fed by frequency converter." *Electrotechnica & Electronica E+ E* (2008): 21-23.
- [12] Hur, Jae-Jung, Kyoung-Wook Kang, Jong-Su Kim, and Seong-Hwan Kim. "Speed control for direct current motor using an AFE rectifier." *Journal of Advanced Marine Engineering and Technology (JAMET)* 42, no. 10 (2018): 829-835. <https://doi.org/10.5916/jkosme.2018.42.10.829>
- [13] Pyakuryal, Sudeep, and Mohammad Matin. "Ripple control in AC to DC converter." *IOSR Journal of Engineering* 3, no. 1 (2013): 26-30. <https://doi.org/10.9790/3021-03152630>
- [14] Saidur, Rahman, Saad Mekhilef, Mian Basharif Ali, Azadeh Safari, and Hussein A. Mohammed. "Applications of variable speed drive (VSD) in electrical motors energy savings." *Renewable and sustainable energy reviews* 16, no. 1 (2012): 543-550. <https://doi.org/10.1016/j.rser.2011.08.020>
- [15] Sevostyanov, Nikita A., Roman L. Gorbunov, and Maksim A. Zharkov. "Digital control system with an adaptive feedback loop for AC motor PWM drive." In *2018 17th International Ural Conference on AC Electric Drives (ACED)*, pp. 1-4. IEEE, 2018. <http://dx.doi.org/10.1109/ACED.2018.8341704>.
- [16] Gurle, N., T. Sheikh, A. Kumari, and R. Argelwar. "Speed Control of Three Phase Induction Motor by Stator Voltage Control." *Journal of Network Communications and Emerging Technologies* 6, no. 4 (2016): 307-312.
- [17] Ben Regaya, C., A. Zaafouri, and A. Chaari. "Electric drive control with rotor resistance and rotor speed observers based on fuzzy logic." *Mathematical Problems in Engineering* 2014 (2014). <https://doi.org/10.1155/2014/207826>
- [18] Andreescu, Gheorghe Daniel. "Position and speed sensorless control of PMSM drives based on adaptive observer." In *Proc. EPE*, vol. 99, pp. 1-10. 1999.
- [19] Ostovic, Vlado. "Pole-changing permanent-magnet machines." *IEEE Transactions on Industry Applications* 38, no. 6 (2002): 1493-1499. <http://dx.doi.org/10.1109/TIA.2002.805568>
- [20] Ostovic, Vlado. "Memory motors." *IEEE Industry Applications Magazine* 9, no. 1 (2003): 52-61. <https://doi.org/10.1109/MIA.2003.1176459>
- [21] Ejiolor, Oti Stephen, Okoli Chinweike, Idoko Hillary, Obe Titus, and C. O. Ebele-Muolokwu. "Dynamics of a Slip Power Recovery Scheme." *Journal of Controller and converters* 4, no. 3 (2019): 35-42. <http://doi.org/10.5281/zenodo.3559326>
- [22] Gulbudak, Ozan, and Mustafa Gokdag. "Model predictive control of two separate induction machines using dual-output indirect matrix converter." In *2019 1st Global Power, Energy and Communication Conference (GPECOM)*, pp. 194-199. IEEE, 2019. <https://doi.org/10.1109/GPECOM.2019.8778475>
- [23] Gulbudak, Ozan, and Mustafa Gokdag. "Dual-Hysteresis Torque Control of Multi-Induction Machines fed by a Nine-Switch Inverter." In *2021 IEEE 30th International Symposium on Industrial Electronics (ISIE)*, pp. 1-6. IEEE, 2021. <https://doi.org/10.1109/ISIE45552.2021.9576225>
- [24] Gulbudak, Ozan, and Mustafa Gokdag. "Predictive dual-induction machine control using nine-switch inverter for multi-drive systems." In *2018 IEEE 12th International Conference on Compatibility, Power Electronics and Power Engineering (CPE-POWERENG 2018)*, pp. 1-6. IEEE, 2018. <https://doi.org/10.1109/CPE.2018.8372496>
- [25] Ho, Tze-Yee, Cong-Khoi Huynh, Yuan-Joan Chen, and Cong-Fong Yan. "The Design And Implementation Of A Sensorless Delta-Connected Brushless Direct Current Motor Drive For Home Appliances." In *2020 3rd international conference on robotics, control and automation engineering (rcae)*, pp. 78-83. IEEE, 2020.
- [26] Ammar, Abdelkarim, Billel Talbi, Tarek Ameid, Younes Azzoug, Abdelaziz Kerrache, Amor Bourek, and Abdelhamid Benakcha. "Predictive direct torque control with reduced ripples and fuzzy logic speed controller for induction motor drive." In *2017 5th International Conference on Electrical Engineering-Boumerdes (ICEE-B)*, pp. 1-6. IEEE, 2017. <https://doi.org/10.1109/ICEE-B.2017.8191978>