



Journal of Advanced Research in Applied Sciences and Engineering Technology

Journal homepage:
https://semarakilmu.com.my/journals/index.php/applied_sciences_eng_tech/index
ISSN: 2462-1943



Design and Fabrication of a Simple Device for Folding Towel

Nur Akmal Haniffah^{1,2,*}, Mohamad Shahrizan Mohd Kamal¹, Syafawati Hasbi³

¹ Department of Mechanical Engineering, Faculty of Engineering, Universiti Pertahanan Nasional Malaysia, Malaysia

² Department of Mechanical Engineering, Faculty of Engineering, Universiti Malaya, Malaysia

³ School of Engineering, Robert Gordon University, Garthdee Road, AB10 7AQ, Aberdeen, United Kingdom

ARTICLE INFO

Article history:

Received 18 August 2023

Received in revised form 8 November 2023

Accepted 7 April 2024

Available online 5 May 2024

Keywords:

Folding, towel; Ultrasonic sensor; Servomotors; Arduino

ABSTRACT

Electronic technology makes work more manageable, and various electronic gadgets have been invented to assist humans. One of the most time-consuming activities is household chores, such as laundry. Daily laundry tasks are easier to manage with the help of washing and drying machines. However, the folding task is still done by hand and is not automated. A towel is one of the main clothes in daily life. Commonly, people use bare hands to fold the towel. However, this task consumes much time and energy; consequently, boredom, tiredness, and fatigue occur. The existing device to fold towels usually has a large physical compartment and is mainly used for industrial purposes, such as at hotels or laundry shops. The towel-folding machine is in increasing demand in our daily lives. Therefore, this project was developed and designed to eliminate the tedious folding of towels. The main aim is to design and develop an effective mechanism for folding rectangular towels using electronic components. The other objective is to compare the timing of folding rectangular towels using a simple device and by hand. As a result, the prototype represented a semi-automation system incorporating mechanical and electronic designs. The prototype assembly has a folding board made from polypropylene plastic. The amount of time to fold one towel using a semi-automatic folding board remains the same throughout the process, while the amount of time required to fold towels by hand increases. In conclusion, a prototype was designed and developed successfully with various electronic components: HC-SR04 ultrasonic sensor, MG996R servomotor and Arduino. Besides, by comparing the timing of folding rectangular towels using a simple device and by hand, 94 seconds was reduced when folding 50 sheets with the aid of the device, compared to by hand. In other words, the effectiveness of the device is 20%.

1. Introduction

Science and technology are advancing quickly, playing an important role in human progress. Electronic technology is one way to make human work more manageable. Satya *et al.*, [1] investigated a variety of useful and efficient electronic gadgets invented to assist humans in meeting their needs. According to Miller *et al.*, [2], various humanly operated equipment are gradually being

* Corresponding author.

E-mail address: nurakmal@upnm.edu.my

<https://doi.org/10.37934/araset.44.2.221233>

abandoned instead of fully automatic equipment, resulting in automatic equipment dominating human existence.

One of the most time-consuming activities is household chores usually conducted by the housewife [3,4]. This activity is carried out daily and is not complete when home chores are neglected [5,6]. Daily laundry tasks, one of the house chores, are easier to manage with the help of washing machines and dryers. However, the folding task is still done by hand and is not automated. Folding dried garments is one of the domestic duties that is a worry for this topic [7]. Doumanoglou *et al.*, [8] researched how when there are many garments, it takes a long time to fold and tidy up the clothes swiftly and neatly, wasting time for other activities.

A solution to the mentioned issues can be found to reduce lost activity and time. Erlangga [9] developed a tool model that can assist in swiftly folding garments using automated labour. Nurkholis *et al.*, [10] investigated the goal of this research, which was to build a model for a clothing-folding gadget based on Arduino Uno and Gear Servo. The benefits of this tool were investigated in solving solutions for folding garments in a relatively quick and neat manner without folding by hand [11,12]. Many people who fold clothes still use manual ways, such as bare hands [13,14].

A towel is one of the main clothes in our daily life. Commonly, people use their bare hands to fold the towel. However, this task consumes much time and energy; consequently, boredom, tiredness and fatigue occur. The existing device to fold towels usually has a large physical compartment. They are mainly used for industrial purposes, such as at hotels or laundry shops.

The towel-folding machine is in increasing demand in our daily lives. Therefore, this project was developed and designed to eliminate the tedious folding of towels. The main aim is to design and develop an effective mechanism for folding rectangular towels using a few electronic components. The second objective is to compare the timing of folding rectangular towels using a simple device and by hand. In summary, this research paper is about improving the towel folding tool to provide improved features such as reducing folding time, saving physical energy while folding many towels, and overcoming challenges in handling the device if it is complicated.

1.1 Literature Review

The folding of towels will be classified into two types in this project based on technology. The manual folding, done by hand, is the first step. It is the most ancient method today. The second type is the semi-automated method, in which the garments are set out on a platform and subsequently folded by the machine. This two-type folding towel was undergoing extensive investigation because no complete breakthrough has been realised in this area.

The folding board, also known as the flip fold, comprises four rectangular pieces: two long rectangular boards and two small rectangular boards that fold the towel into a perfect rectangle. Only the upper middle section of the board is connected to the rest. Towels are folded by flipping the different parts of the board in a primary sequence. Mostly, the board's material is made of Polypropylene resin. This lightweight and easy-to-handle fabric folder was suitable for this innovation.

One form of energy can be transformed into another by using a sensor, which is a device that detects and then responds to various types of physical world input. Ultrasonic sensors use ultrasonic waves to measure distance. The sensor head produces an ultrasonic signal and receives a signal to detect the target. When using ultrasonic sensors, the distance to a target is determined by determining how long it takes the sensor to emit and receive the signal. Emission and reception are accomplished with the help of a single ultrasonic element. A single oscillator transmits and receives

ultrasonic waves in a reflecting model ultrasonic sensor. This sensor will detect a towel approaching the mainboard and give Arduino input to operate the device.

Servomotors are automatic devices with a rotary turning angle of 360 degrees according to the setup, mostly connected to the Arduino Uno. It can rotate or push parts of the board with precision. Servos are primarily used to control angular or linear position, velocity, and acceleration. The input voltage varies depending on the size and torque output of the servo; however, most servos will operate nicely with 5V from a microcontroller or battery circuit. A servo's current draw can pull while moving and, with a load attached, is more essential than voltage. When unloaded, a typical hobby servo can draw as little as 10mA, but larger servos under load can draw up to an Ampere or more. It is crucial to ensure the power supply has the appropriate voltage range and generates enough current to move the servo with the towel attached to the board. Table 1 shows a summary literature review on the servomotor and ultrasonic sensors.

Based on the findings in Table 1, an MG996R would be used in this study since it is a servomotor with a maximum stall torque of 11 kg/cm and metal gears. The motor rotates from 0 to 180 degrees based on the duty cycle of the PWM wave given to its signal pin, just as other RC servos. Besides, an HC-SR04 ultrasonic sensor would be used since it sends out sound waves at a frequency of 40 kilohertz, which move through the air and detect the presence of any obstacles or objects in their path.

An Arduino is a circuit board programmed to do various tasks today, where programming is commonly utilised. An Arduino can read and send information from multiple sensors, antennas, and coding devices. It can also output data to various devices, such as LCD screens and stereo speakers. It sends data from a computer program to the microcontroller, executing a specific command. Software (The Arduino IDE) that inputs the information on commands and hardware (Arduino Uno circuit board) with many components to make it work are used together to program the device. In other words, the primary purpose of Arduino is to execute code within the Arduino Integrated Development Environment (IDE) and provide communication between input and output sensors. [19]. Arduino is widely utilised in fields like medicine, agriculture, traffic monitoring, robotics, and automation [20].

Table 1
 Summary of literature review on the ultrasonic sensor and servomotor

Author	Title	Objective	Method	Result / Findings
Arun <i>et al.</i> , [15]	Object detection using ultrasonic sensor	The time it takes for ultrasonic waves to spread out and measure the distance they travel from the system to the target and return.	Arduino has a "Wiring" library. It generates many sophisticated input/output functions.	When an object is detected, its existence, angle, and distance are presented. This project can ensure human safety by detecting object interference at a specific distance. Finally, the project's goal has been reached without a hitch.
Latha <i>et al.</i> , [16]	Distance Sensing with Ultrasonic Sensor and Arduino	To create and test an ultrasonic distance meter. The gadget presented here can detect the target and calculate its distance.	The most common method is the time of flight (ToF). ToF measures the time between an ultrasonic pulse train's emission and arrival after reflection. This slows single-measurement reaction times.	The device accurately measures distance. It measures distance without touching anything. The device is versatile. It's used in car backing systems, automation and robotics, snow depth, tank water level, and manufacturing line detection.
Sadun <i>et al.</i> , [17]	A Comparative Study on the Position Control Method of DC Servomotor with Position Feedback by using Arduino	A servo motor is an actuator that can be accurately regulated regarding rotary and angular position.	Arduino IDE was used to code servomotor control.	Any closed-loop electrical system can use a positional rotation servo. Advantages include accurate angular position adjustment and real-time position feedback. Built-in potentiometer voltage feedback indicates the motor's exact angular location.
Irawan <i>et al.</i> , [18]	Folding Clothes Tool Using Arduino Uno Microcontroller and Gear Servo	To design a model for clothes folding devices based on Arduino Uno and Gear Servo.	The microcontroller was designed with a servomotor as a clothes-folding medium. There was hardware programming.	After testing, the author concluded that clothes-folding devices in a microcontroller with a servo drive could be assembled with 3 to 6 servos, depending on clothing size. Because there are only three servos and they can only bear a small load, add six servos, one on each side of the current servo placement.

2. Methodology

Figure 1 shows the process and development throughout the fabrication of semi-automatic folding towel parts in the flow chart form.

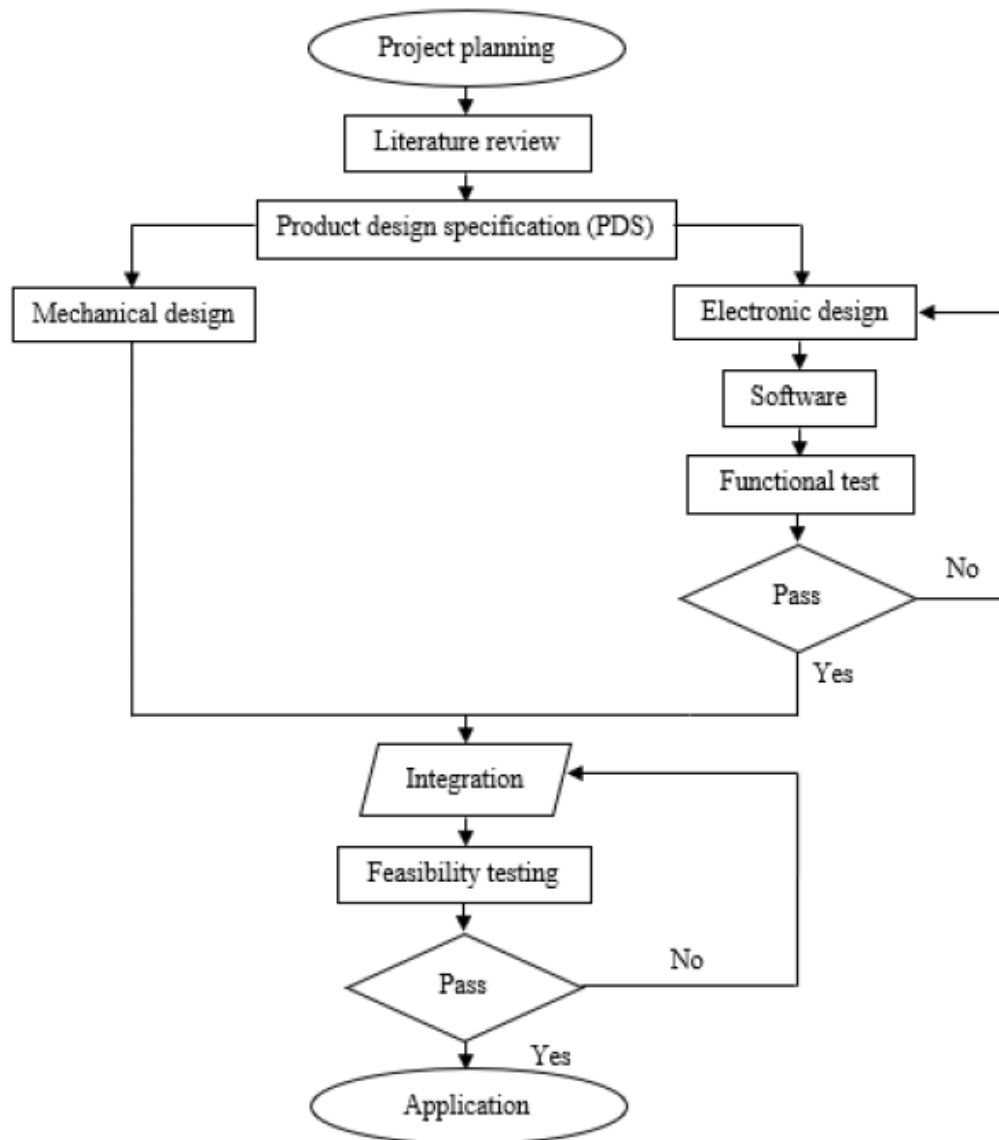

Fig. 1. Flowchart for design and fabrication of part for a folding device

This project's background study is based on the folding bolding board, servomotor, ultrasonic sensor, and Arduino literature review. Product Design Specifications (PDS) were built based on the customer requirements and used for conceptual design generation. Mechanical design, including the few designs concept, concept evaluation, weight decision matrix, technical drawing and fabrication. Electronic design, including coding in the software and electronic functional testing. Lastly, feasibility testing was done to determine whether or not the prototype could operate properly.

2.1 Potential Difficulties and Challenges of the Product

The product was expected to encounter specific difficulties while used for folding purposes. As a result, four presumptive difficulties were identified, and a recommended method for resolving them was. Table 2 shows potential difficulties and challenges for a folding towel device.

Table 2
 Potential difficulties and challenges for a folding towel device.

Challenges / Difficulties	Effect on product	Proposed solution
Less durable power supply	Fewer towels cannot be fold	Using direct current or using a battery with a large mAh capacity
Electronic compartment functionality	<ul style="list-style-type: none"> • The ultrasonic sensor does not detect towels that are placed on board. • The servo is stuck and unable to move the board. 	<ul style="list-style-type: none"> • Place the ultrasonic sensor in a place that makes it easy to detect the towel. • Choose a servo with high durability and power.
Material of the board	<ul style="list-style-type: none"> • Heavy to lift. • Towel slips from the board. 	Using light material with a rough surface, such as plastic or polypropylene resin.
Coding	Wrong instructions given on the Arduino will affect the process of folding	Try and error on coding to manage the proper process of folding towels neatly

2.2 Product Design Specification (PDS)

A product design specification is a product requirement, as shown in Table 3. It provides all the product information with specific features and functionalities and offers a technical description, performance specification, technical standards to meet, and other details. The project design specification is based on the general requirement.

Table 3
 Product design specification (PDS)

General Requirement	Specific Requirement	Acceptance Performance
Automatic	Auto-fold the towel	<ul style="list-style-type: none"> • Using Arduino to generate the folding board. • Servo to move and fold the towel.
Safety	No harm to the user	<ul style="list-style-type: none"> • No sharp edge on the product. • All electronic compartments will be covered.
Quality	<ul style="list-style-type: none"> • Fold in a nice shape. • Easy to use. • Lifespan. • Lightweight and durable material. 	<ul style="list-style-type: none"> • Neat fold shape. • Place a towel on the product, and it will fold automatically. • Long-lasting. • Not easy to break.
Dimension	<ul style="list-style-type: none"> • Portable and easy to carry. • Easy to move. • Easy to store. 	<ul style="list-style-type: none"> • Length: 58 cm. • Width: Fold = 24cm, Unfold = 72 cm. • Height: 7 cm.
Reduce time	<ul style="list-style-type: none"> • Shorter time to fold with a neat shape. • Simple installation process. 	< 1 min

2.3 Conceptual Design

Design concept generation entails creating many goods to investigate product design specifications. This procedure begins with client criteria and concludes with several concept design possibilities to select a final design. Several concept hand sketches were drawn on A4 paper. In this project, four designs were created and compared to find the most satisfactory product. Figure 2 shows four sketches of four concepts for a folding device.

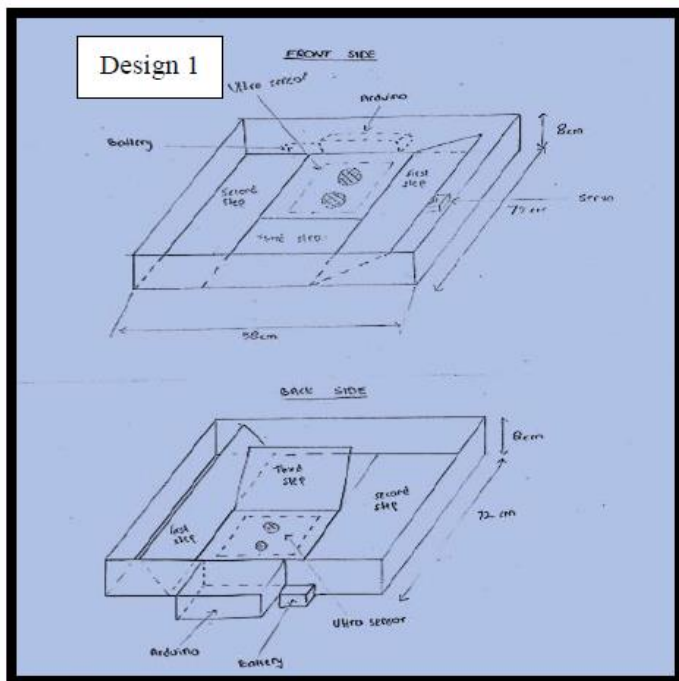

(a) Design 1

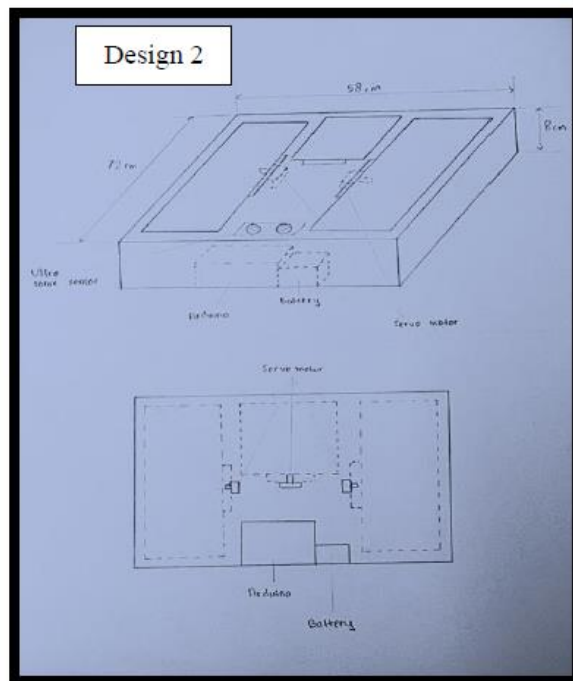

(b) Design 2

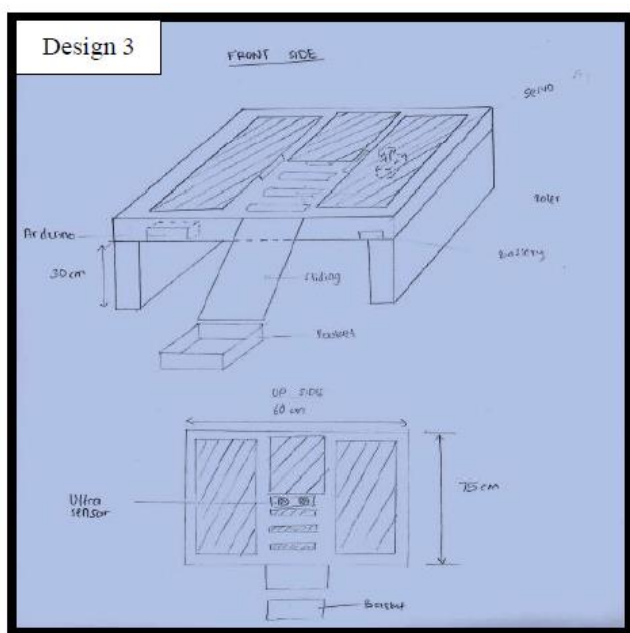

(c) Design 3

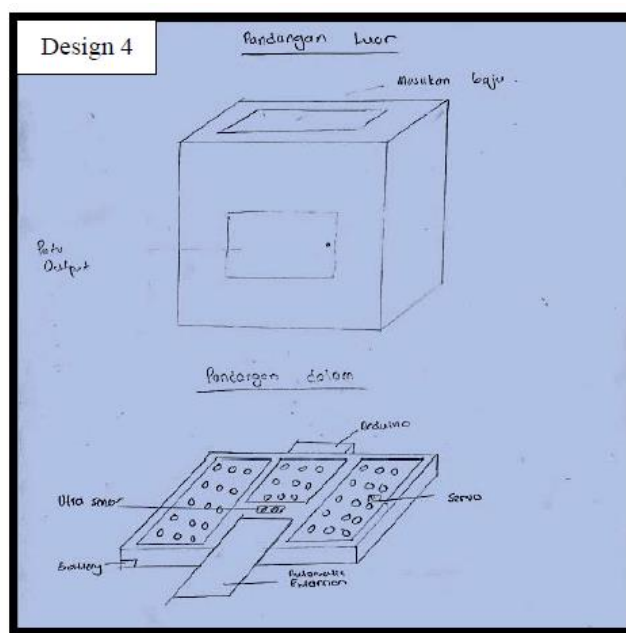

(d) Design 3

Fig. 2. Sketch of four concepts for a folding device

Based on Figure 2(a), this sketch provides the simplest design that fulfils the folding towel requirement. With human power to put the towel on the mainboard, the ultrasonic sensor commands the Arduino and moves the other board to fold the towel. The board and all electronic parts are secure in the box to avoid breaking easily. Besides, design concept 2 (Figure 2(b)) has a folding board on top that supports more towel size, and other electronic parts are secure under the box. The ultrasonic sensor will instruct the Arduino to move the other board to fold the towel. The board and all electronic components are safely enclosed in a box to prevent accidental damage.

Design concept 3 differs from other designs, as shown in Figure 2(c). The ultrasonic sensor will instruct the Arduino to move the other board to fold the towel. The uniqueness of this design is the existence of a slide. After the towel has been folded, it will slide into the basket. Every component is electronically stored in the body to avoid any damage. The design looks safer based on design concept 4 (Figure 2(d)) because the system is located in a box made from quality stainless steel. The system cannot be seen in this design since every electronic component and board is in the box. Therefore, the consumer only needs to put the towel in the box. As a result, the Arduino will tell the second board to fold a towel using an ultrasonic sensor. Finally, the consumer takes the towel from the output port.

2.4 Concept Evaluation

All four design concepts were analysed and screened to develop a final design concept. Each design concept was run through the Pugh design concept selection table in the first step. Based on comparing the current folding device with the product design specification, some features were identified, and scores were given, as shown in Table 4. A score of (-) is given to the designs that do not satisfy the criteria by the potential user, while (+) is given to the designs that meet advanced standards, and (0) is allocated to the designs that follow the reference. Add all of the (0), (+), and (-) to get a net score for each design concept. The top two design ideas with the highest net score will move on to the next phase of the screening.

Table 4
 Pugh design concept selection for 4 designs

Features	Design Concept Variation				Reference
	Design 1	Design 2	Design 3	Design 4	
Effectiveness of mechanism	0	0	0	0	0
Capacity	-	+	+	+	0
Safety	+	+	+	-	0
Weight	+	+	-	-	0
Cost	0	0	-	-	0
Maintenance	0	0	0	0	0
Storage capacity	+	+	-	-	0
Plus	3	4	2	1	
Same	3	3	2	2	
Minus	1	0	3	4	
Nett	2	4	-1	-3	
Rank	2	1	3	4	
Continue?	YES	YES	NO	NO	

2.5. Weight Decision Matrix

The two design concepts that made it past the first screening stage will be subjected to the second stage to determine which will be produced in this project. The design ideas that passed the previous screening are Design 1 and Design 2. In the next screening exam, a weighted choice matrix will be used. Each design concept will be given points based on the selection criteria. Prior to that, a score of 1 to 5 will be assigned to each of the seven qualities used in the selection criterion. All of these categories will be defined, as shown in Table 5. Each unique design concept will be rated, awarding a score to the design ideas. Each criterion will be awarded 100% based on its importance. The rate allocated to each of the seven design ideas will compound this percentage weighting.

Table 5
 Weight Decision Matrix for 2 designs

Criteria	Weightage (%)	Concepts			
		Design 1	Design 2		
		Rating	Weightage score	Rating	Weightage score
Safety	20 %	3	0.6	5	1
Capacity	15 %	3	0.45	4	0.6
Effectiveness of mechanism	15 %	5	0.75	5	0.75
Maintenance	15 %	5	0.75	5	0.75
Cost	15 %	4	0.6	4	0.6
Weight	10 %	5	0.5	3	0.3
Storage space	10 %	4	0.4	5	0.5
Total score		29	4.05	31	4.50
Ranking		2		1	
Continue?		NO		YES	

2.5. Materials

The fabricated parts, acrylic plates, were chosen and cut using a cutting machine according to the dimensions in the drawing. The acrylic plates were put together with acrylic glue and hot glue. Hinges and locks were used, too. Referring to the previous literature review, a folding board, besides the HC-SR04 ultrasonic sensor, MG996R servo motor, and Arduino Uno R3, were used as electronics parts.

3. Results and Discussion

The folding towel device may be described as a semi-automatic device that an Arduino controls as the brain and other electronic components, such as an ultrasonic sensor, servo motors, and a battery for power. Before moving on to the following procedure, this technology requires human physical energy to place the towel on the board. The first question is whether the servo is powerful enough to move the board when loaded with a towel. Next, if the ultrasonic sensor fails to detect the presence of towels on the board, the entire system will fail to work. The last point to consider is how adaptable the equipment is to folding many towels simultaneously. In order to save energy and time, it is hugely beneficial if the device can withstand several folds without difficulty. Figure 3 shows the full assembly of a semi-automatic folding device.

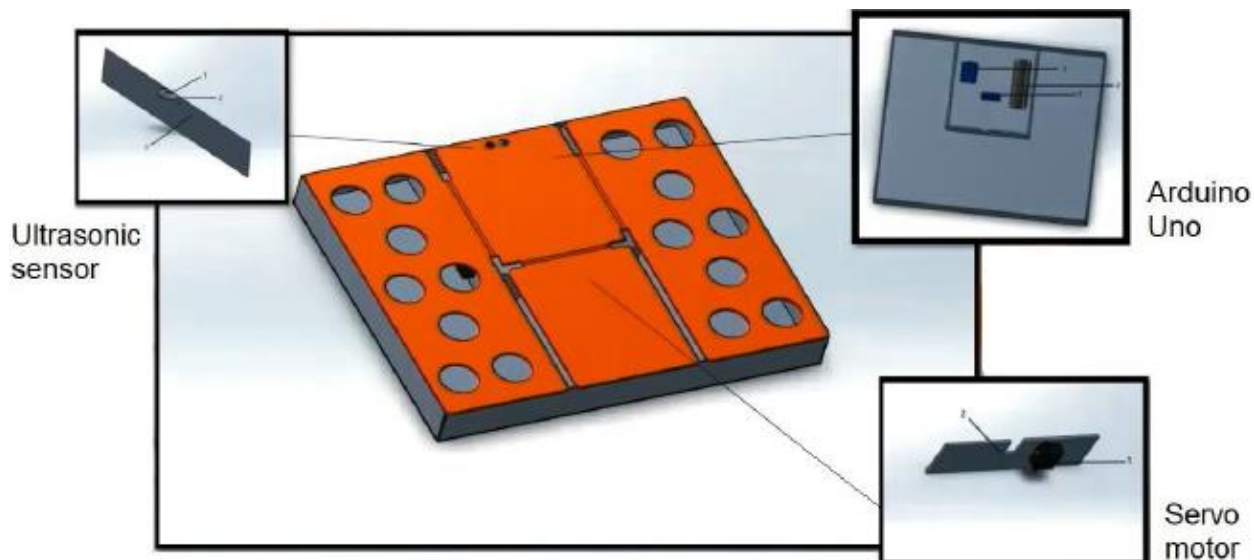

Fig. 3. Full assembly of a semi-automatic folding device

The prototype for this project was developed by putting together all the parts. Figure 4 shows the prototype assembly with a folding board made from polypropylene plastic. Figure 5 shows the step of the semi-automatic folding device function. Objective 2 is to compare the timing between using the semi-automatic folding device and folding using a bare hand. Usually, folding towels in small quantities will be easier and faster when folded by hand, but the result of folding depends on one's tidiness. However, folding towels in large quantities will cause tiredness and fatigue to the folders, and the result will be less neat.

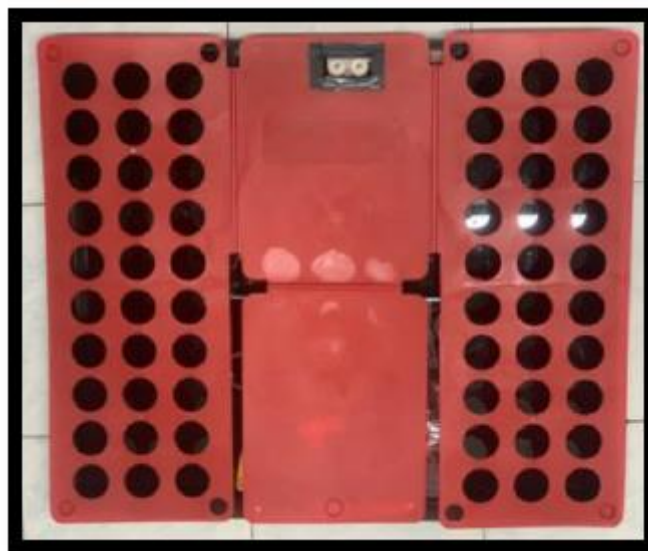

Fig. 4. Full assembly of the prototype

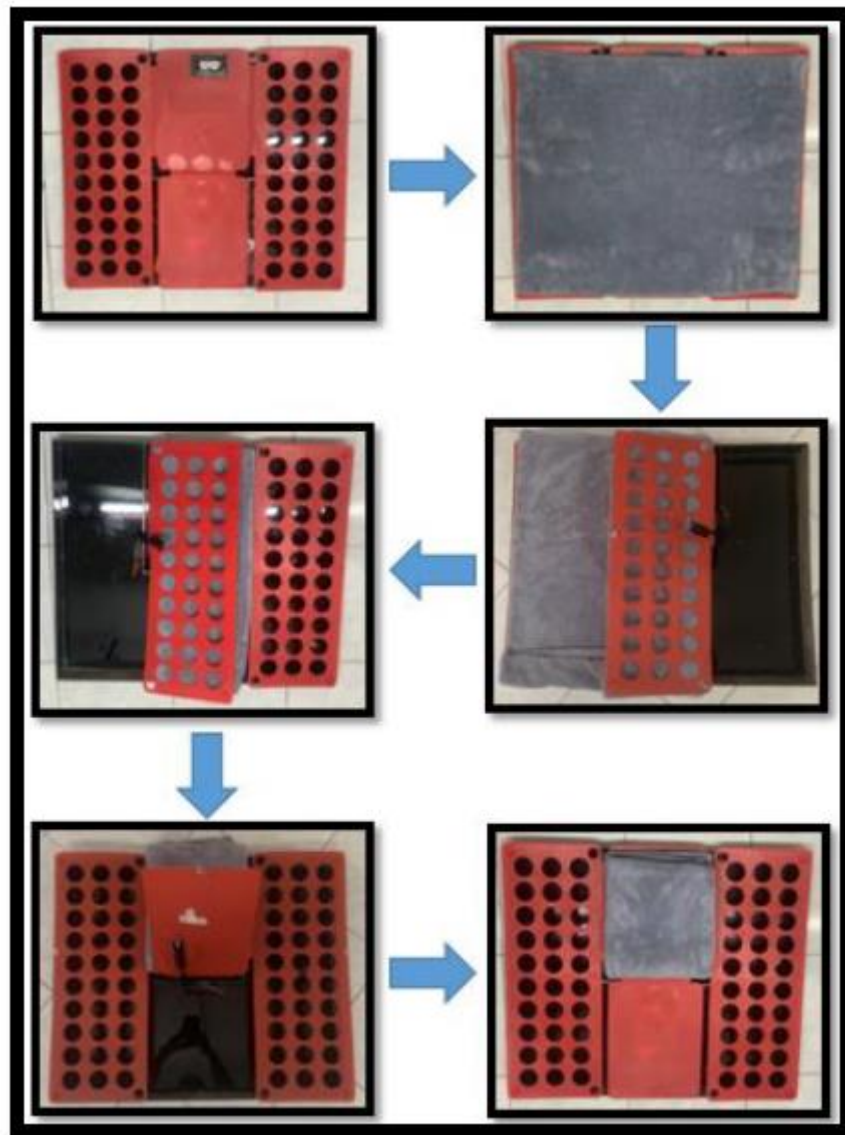

Fig. 5. The process of folding towel

Figure 6 shows the time to fold each towel from the first to the 50th sheet, using bare hands and a semi-automatic device. The amount of time to fold one towel using a semi-automatic folding board remains the same throughout the process, while the amount of time required to fold towels by hand increases due to human factors such as boredom, tiredness, and fatigue. 94 seconds was reduced when folding 50 sheets with the aid of the device, compared to by hand. In other words, the effectiveness of the device is 20%.

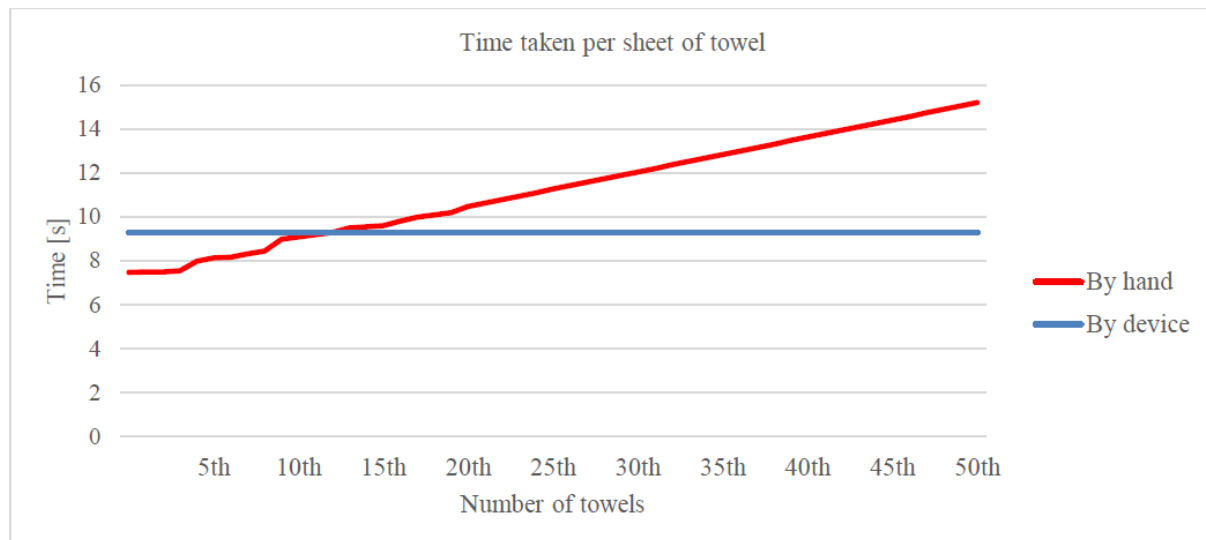

Fig. 6. Time comparison between by hand and a semi-automatic device

4. Conclusion

People often want to simplify daily affairs to save time and energy so that more other matters can be done. Much research has been done to make things easier and create an atmosphere where people take easy steps to complete their tasks. This project's device represented a semi-automation system incorporating mechanical and electronic control designs. In conclusion, a prototype was designed and developed successfully with various electronic components: HC-SR04 ultrasonic sensor, MG996R servomotor and Arduino. Besides, by comparing the timing of folding rectangular towels using a simple device and by hand, 94 seconds was reduced when folding 50 sheets with the aid of the device, compared to by hand. In other words, the effectiveness of the device is 20%. As a recommendation for improvement, the electronic component should be replaced with a faster mechanism component. Besides, the product functionality is suggested to fold other garments of various shapes and types.

Acknowledgement

This research was funded by the Faculty of Engineering, Universiti Pertahanan Nasional Malaysia.

References

- [1] Satya Baktiar, I. K., & Nugroho, P. W. "Automatic clothes folding machine based on PLC (Programmable Control Logic) as an alternative to help clothing activities." Final Project of Mechanical Engineering Department-Faculty of Engineering UM, 2017:86- 89.
- [2] Miller, Stephen, Mario Fritz, Trevor Darrell, and Pieter Abbeel. "Parametrized shape models for clothing." In *2011 IEEE International Conference on Robotics and Automation*, pp. 4861-4868. IEEE, 2011. <https://doi.org/10.1109/ICRA.2011.5980453>
- [3] Hariyanti, E., G. Tambunan, R. A. Saputra, N. C. Basjaruddin, and E. Rakhman. "Automatic clothes folding device with three microcontroller-based folding modes." In *2020 Proceedings of Industrial Research Workshop And National Seminar*, vol. 11, no. 1, pp. 205-210. 2020.
- [4] Mouleeshuwarappabu, R., B. Kousika, A. Hariprasath, and S. Giritaran. "Arduino UNO based Automated Folding System for Textiles." In *2023 7th International Conference on Trends in Electronics and Informatics (ICOEI)*, pp. 221-226. IEEE, 2023. <https://doi.org/10.1109/ICOEI56765.2023.10126033>
- [5] Osawa, Fumiaki, Hiroaki Seki, and Yoshitsugu Kamiya. "Clothes folding task by tool-using robot." *Journal of Robotics and Mechatronics* 18, no. 5 (2006): 618-625. <https://doi.org/10.20965/jrm.2006.p0618>

- [6] Deng, Eric, Bilge Mutlu, and Maja J. Mataric. "Embodiment in socially interactive robots." *Foundations and Trends® in Robotics* 7, no. 4 (2019): 251-356. <http://dx.doi.org/10.1561/2300000056>
- [7] Fred, H. U.S. Patent No. 2,071,257. Washington, DC: U.S. Patent And Trademark Office, 2013.
- [8] Doumanoglou, Andreas, Jan Stria, Georgia Peleka, Ioannis Mariolis, Vladimir Petrik, Andreas Kargakos, Libor Wagner, Václav Hlaváč, Tae-Kyun Kim, and Sotiris Malassiotis. "Folding clothes autonomously: A complete pipeline." *IEEE Transactions on Robotics* 32, no. 6 (2016): 1461-1478. <https://doi.org/10.1109/TRO.2016.2602376>
- [9] Erlangga, M. Automation of Arduino-Based Clothes Folding Machines Based on Patent No. 2,758,761 (In 2019 Doctoral Dissertation, University Of Muhammadiyah Malang), 2019.
- [10] Nurkholis, A. M., & Alfi, I. Automatic F-Cloth Smart Solution for Folding Clothes Practically Based on Arduino Uno (In 2018 Doctoral Dissertation, University Of Technology Yogyakarta), 2018.
- [11] Wahyuni, Refni, and Yuda Irawan. "Web-based employee performance assessment system in PT. Wifiku Indonesia." *Journal of Applied Engineering and Technological Science (JAETS)* 1, no. 2 (2020): 60-69. <https://doi.org/10.37385/jaets.v1i2.62>
- [12] Irawan, Yuda, and Refni Wahyuni. "Electronic equipment control system for households by using android based on IoT (Internet of Things)." In *Journal Of Physics: Conference Series*, vol. 1783, no. 1, p. 012094. IOP Publishing, 2021. <https://doi.org/10.1088/1742-6596/1783/1/012094>
- [13] Hafis, A. S. A. Design of Semi-Automatic Clothes Folding Machine Based on Arduino Uno (In 2019 Doctoral Dissertation, University Of Muhammadiyah Malang), 2019.
- [14] Kido, Megumi, and Hiroki Takahashi. "Clothing model fitting for laundry folding assistance." In *2019 Nicograph International (NicoInt)*, pp. 37-40. IEEE, 2019. <https://doi.org/10.1109/NICOInt.2019.00015>
- [15] Arun Francis, G., M. Arulselvan, P. Elangkumaran, S. Keerthivarman, and J. Vijaya Kumar. "Object detection using ultrasonic sensor." *Int. J. Innov. Technol. Explor. Eng* 8 (2020): 207-209.
- [16] Latha, N. Anju, B. Rama Murthy, and K. Bharat Kumar. "Distance sensing with ultrasonic sensor and Arduino." *International Journal of Advance Research, Ideas and Innovations in Technology* 2, no. 5 (2016): 1-5.
- [17] Sadun, Amirul Syafiq, Jamaludin Jalani, Jumadi Abdul Sukor, and Batu Pahat. "A comparative study on the position control method of dc servo motor with position feedback by using arduino." In *Proceedings of Engineering Technology International Conference (ETIC 2015)*, pp. 10-11. 2015.
- [18] Irawan, Yuda, Refni Wahyuni, and Hendry Fonda. "Folding clothes tool using arduino uno microcontroller and gear servo." *Journal of Robotics and Control (JRC)* 2, no. 3 (2021): 170-174. <https://doi.org/10.18196/jrc.2373>
- [19] Nathan, Shelena Soosay, Kuan Jung Ying, Lim Hui Wen, and Lim Xin Weoi. "Design of Smart Walking Shoe for Visually Impaired People." *Journal of Advanced Research in Applied Mechanics* 101, no. 1 (2023): 53-61. <https://doi.org/10.37934/aram.101.1.5361>
- [20] Sudianto, Agus, Zamberi Jamaludin, Azrul Azwan Abdul Rahman, Fajar Muharrom, and Sentot Novianto. "Smart temperature measurement system for milling process application based on mlx90614 infrared thermometer sensor with Arduino." *Journal of Advanced Research in Applied Mechanics* 72, no. 1 (2020): 10-24. <https://doi.org/10.37934/aram.72.1.1024>