



## Characteristic Performance Comparison of Schottky Diodes for RF Energy Harvesting

Abdulrahman Amin Ahmed Ghaleb<sup>1</sup>, Ismahayati Adam<sup>1,2,\*</sup>, Mohd Najib Mohd Yasin<sup>1,2</sup>, Raja Nor Azrin Raja Yunus<sup>1</sup> and Muhammad Fitra Zambak<sup>3</sup>.

<sup>1</sup> Faculty of Electronic Engineering & Technology, Universiti Malaysia Perlis, 02600 Arau, Perlis, Malaysia

<sup>2</sup> Advanced Communication Engineering (ACE) Centre of Excellence, Universiti Malaysia Perlis, 02600 Arau, Perlis, Malaysia

<sup>3</sup> Magister Teknik Elektro, Universitas Muhammadiyah Sumatera Utara, Kota Medan, Sumatera Utara 20238, Indonesia

### ABSTRACT

Radio frequency energy harvesting is the process of capturing and converting ambient radio frequency (RF) waves into usable electrical energy. The basic principle behind RF energy harvesting involves the use of antenna for capturing the wave while the rectifier used to convert AC to DC. The diode is an important component of the rectifier circuit that influence the conversion efficiency of the rectifier circuit. HSMS2860 Schottky diode is chosen in analysing the diode performance based on power conversion efficiency (PCE). To verify diode performance, the diode I-V curve has been modelled using Advanced Design Systems (ADS) with a simple impedance matching network for the sub-6GHz frequency band for 5G communication. The diode characterization is done in a mathematical model and a simulation model for a single series diode to test the PCE based on the output voltage. HSMS2860 showed the highest results of all diodes tested for both simulation and mathematical model except for low input power. The performance was tested further by a single-stage voltage doubler which shows a full-wave rectification and a PCE of 87%.

#### Keywords:

Characterization; rectifier; RF energy harvesting; Schottky diode

### 1. Introduction

Radio frequency energy harvesting (RFEH) has been the researchers' focus due to the implementation of large number of wireless devices [1, 2] and the advanced use of wireless technology [3]. RFEH is the process of converting the electromagnetic waves into useful and manageable electric power [4, 5], where the source can be from ambient or dedicated RF energy [6], [7]. Generally, ambient RF energy from WIFI and cellular network might be sufficient to low power electronic devices [8, 9]. Even though the power generated in RFEH is small compared to other EH [10, 11], the bright side is the energy is always there, it has been continuously radiated in the environment, thus no effort needed to create the source [12].

\* Corresponding author.

E-mail address: [ismahayati@unimap.edu.my](mailto:ismahayati@unimap.edu.my)

<https://doi.org/10.37934/araset.55.1.222229>

Quadband rectifier were proposed in previous works [3, 7, 13, 14] using HSMS2850 Schottky diode, where efficiency varies from 30% to 70% by a single stage voltage doubler. While works in [4, 15, 16], used SMS3670 in their proposed rectifier circuit resulted in minimum efficiency of 45%. A frequency-dependent multiple antenna that enables the harvester to fully exploit all available frequency bands, including 0.94, 1.81, 2.42 and 2.90 GHz frequency bands using a single-series diode topology [3]. The design yields 0.797 V output voltage and 55.5%, 52.5%, 66.52%, 52.9% and 65.5 % PCE at -27dBm input power. A voltage doubler rectifier is designed to operate at 2.4 GHz frequency band resulting to an output of 1.6 V and 45% PCE at 5 dBm input power [15].

In work [17], a voltage doubler circuit is designed and implemented with the help of microstrip transmission lines, used for impedance matching between the antenna and the rectifier for the optimum power transfer from the antenna to the load for the operation dual bands of universal mobile telecommunication service and WIFI, covering 2.15 and 2.45 GHz frequency bands the design yield an output of 0.96 V and 42% PCE at 0 dBm input power. A simple impedance matching network by using Smith chart utility in [12] was designed for each frequency band according to the impedance found at each band. These frequencies cover 0.9, 1.8, 2.1 and 2.45 GHz. The rectifier circuit is voltage doubler which generates 1.662, 1.422, 1.333, and 1.587 V output voltage and 74.846%, 66.974%, 64.486%, and 61.407% at each frequency at the input power of 0dBm, respectively. [14] used transmission Line as Input Impedance matching network operates at 900 MHz using voltage doubler rectifying circuit. The circuit produces a 0.6 V and 44.30% PCE at 0 dBm input power. On the other hand, CMOS based rectifiers were designed in works [18, 19], however, the designs were complex and face many challenges, such as, high threshold voltage and body effect of the CMOS transistors.

The focus on this work is on a simple single voltage doubler using HSMS2860 diode. Prior to rectifier design, a characterization on the diode component is done to verify the diode characteristics. Next, the comparison between a mathematical model and simulation is presented. Finally, a single stage voltage doubler is presented and analyzed based on the diode characteristics and mathematical model. Wireless communication technologies such as ISM, GSM, and LTE/4G/5G frequency bands are deemed probable candidates for RFEH [20]. Due to the growth of wireless communication and current developments toward 5G technology, all the analysis done in this paper are based on 700 MHz frequency band of 5G communication technology.

## 2. Diode Modelling

Diode-based rectifier circuits are the most popular because they have a lower forward voltage drop than CMOS circuits [6]. The diode is an important component of the rectifier circuit as it influences the conversion efficiency of the rectifier circuit. Most researchers used Schottky diodes in high frequency and RFEH applications in their works due to their low threshold voltage drop such as, SMS7630, HSMS2820, HSMS2850, and HSMS2860 [1, 3, 5, 7, 13]. In this paper, HSMS2860 Schottky diode is chosen for modeling with its junction capacitor, series resistance, and voltage threshold voltage of 0.18 pF, 6  $\Omega$ , and 0.65 V respectively. The diode linear equivalent circuit has been modeled using Advanced Design Systems (ADS) as shown in Figure 1(a). The  $R_s$  is the series resistor,  $C_j$  is the junction capacitance, and the  $R_j$  is the junction resistance calculated using Eq. (1), where  $n$  is equal to 1.08 and the saturation current ( $I_s$ ) is 50 nA.

$$R_j = \frac{8.33 \times 10^{-5} n T}{I_b + I_s} \quad (1)$$

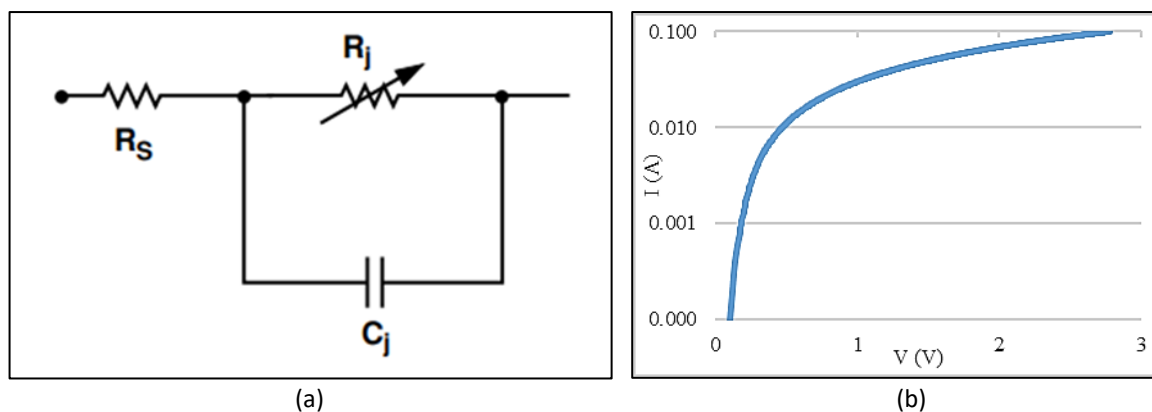
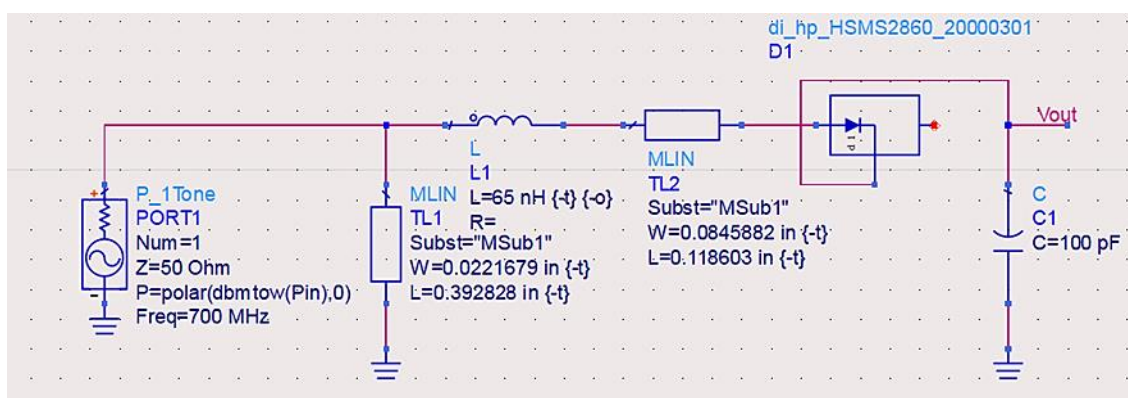
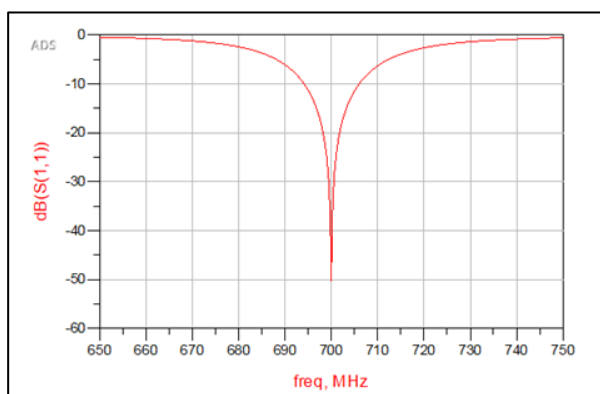

Fig. 1. (a) Diode linear equivalent circuit model (b) Voltage versus current curve

The I-V curve plot under forward biased is illustrated in Figure 1(b) where it is calculated at temperature (T) of 298K. It showed that the forward biased voltage is increase as the current is increase and reached saturation above 100 mA forward current. Figure 2(a) show a simple impedance matching network for a 700 MHz circuit with a 65 nH inductor in series with the Schottky diode. A lumped element of 100 pF of load capacitance were placed at the output. The circuit is simulated in ADS software, and it well matched at 700MHz with a return loss of -50 dB as shown in Figure 2(b). Harmonic balance tool in ADS were used to simulate the circuit performance in term of output power, where the result is shown in Figure 2(c). The input power was varied from -50 dBm to 0 dBm, and the voltage output reached 1V for -7 dBm input power. The analysis continues further with comparison between mathematical calculation with circuit simulation in the next section.



(a)



(b)

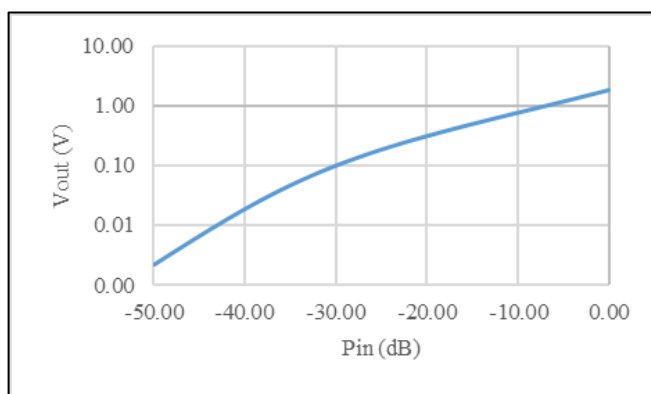

(c)

Fig. 2. (a) HSMS-2860 detector circuit (b) S-parameter result (c) Input power versus output voltage

### 3. Performance Comparison by Mathematical Model and ADS Simulation

The diode performance based on power conversion efficiency (PCE) is analyzed using Eq. (2). The mathematical equations are modeled in *Scilab* numerical computational software. The A, B, and C in equation to is calculated using Eq. (3).  $V_j$ ,  $R_s$ , and  $C_{j0}$  represent voltage across the diode, series resistance, and junction capacitance at zero bias respectively.  $R_L$ ,  $\theta_{on}$ , and  $C_j$  represent load resistance, forward bias turn on angle, and junction capacitance. Table 1 consists of SMS7630, HSMS2820, HSMS2850, and HSMS2860 diodes parameters used in the mathematical model.

$$\eta(\%) = \frac{100}{1 + A + B + C} \quad (2)$$

where A, B and C can be calculated in Eq. (3)

$$A = \frac{R_L}{\pi R_S} \left(1 + \frac{V_j}{V_{DC}}\right)^2 \left[\theta_{on} \left(1 + \frac{1}{2\cos^2\theta_{on}}\right) - 1.5\theta_{on}\right], B = \frac{R_L \cdot R_S \cdot C_j^2 \cdot \omega^2}{2\pi} \left(1 + \frac{V_j}{V_{DC}}\right) \left[\frac{\pi - \theta_{on}}{\cos^2\theta_{on}} + \tan \theta_{on}\right],$$

$$C = \frac{R_L}{\pi R_S} \left(1 + \frac{V_j}{V_{DC}}\right) \frac{V_j}{V_{DC}} [\tan \theta_{on} - \theta_{on}] \quad (3)$$

where,

$$\tan \theta_{on} - \theta_{on} = \frac{\pi R_S}{R_L \left(1 + \frac{V_j}{V_{DC}}\right)} \quad (4)$$

$$C_j = C_{j0} \sqrt{\frac{V_j}{V_j + V_{DC}}} \quad (5)$$

**Table 1**

Diode parameter

Diode	$V_j$ (V)	$R_s$ ( $\Omega$ )	$C_{j0}$ (pF)
SMS7630	0.34	20	0.14
HSMS2820	0.65	6	0.7
HSMS2850	0.35	25	0.18
HSMS2860	0.65	6	0.18

The result from the mathematical model is shown in Figure 3 for output range from 0 to 5 Vdc. It can be noticed that HSMS2820 and HSMS2860 have almost an identical power conversion efficiency (PCE) result of 60% as illustrated in Figure 3(a). This can be attributed to their junction threshold voltage and series resistance being identical with a difference in junction capacitance. Whereas Figure 3(b) is the close-up version of Figure 3(a) to observe the output range from 0 to 0.5 Vdc. Noticeable that the SMS7630 and HSMS2850 perform better from 0 to 0.2 Vdc, as they have lower junction voltage. while HSMS2820 and HSMS2860 shows a better PCE at 0.4 Vdc.

Figure 4 shows the simulation circuit, it is a simple single series diode with one transmission line. Diode simulation model is similar to the mathematical model parameters in addition to N, and M, ideality factor, and grading coefficient respectively.  $R_L$  is 50  $\Omega$  for both simulation and mathematical model. The simulation is conducted in ADS software. The results obtained can be seen in Figure 5(a), where the input power is in the range of -30 to 40 dBm. It can be observed that the results of PCE are lower than the mathematical model. This difference can be ascribed to the mathematical model's

utilization of only three parameters for each diode and its assumption of nearly ideal conditions concerning losses. Furthermore, the simulation model has a transmission line that operates as impedance matching that will introduce losses to the circuit. Similar pattern to mathematical model can be seen, where the highest diode results belong to HSMS2860, and lowest belong to HSMS2850.

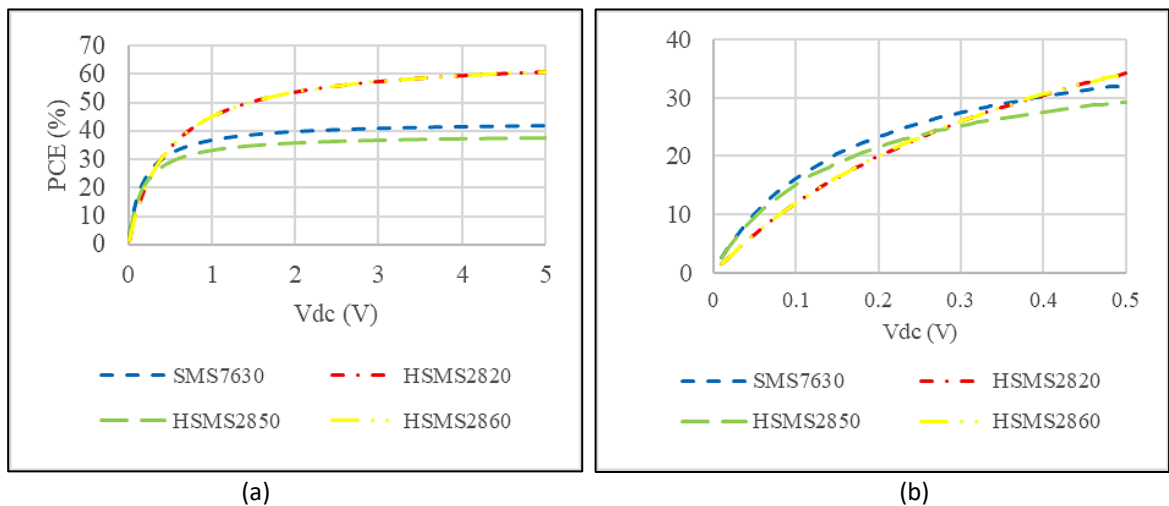

Fig. 3. Power conversion efficiency calculated from mathematical model (a) Vdc 1 to 5V (b) Vdc 0 to 0.5V

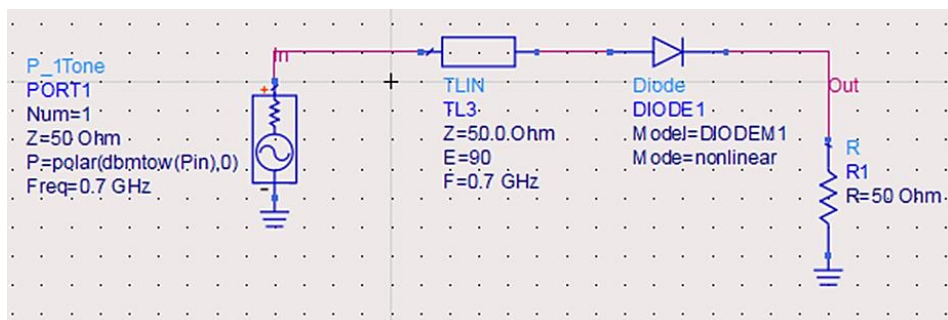

Fig. 4. Single diode in ADS simulation circuit

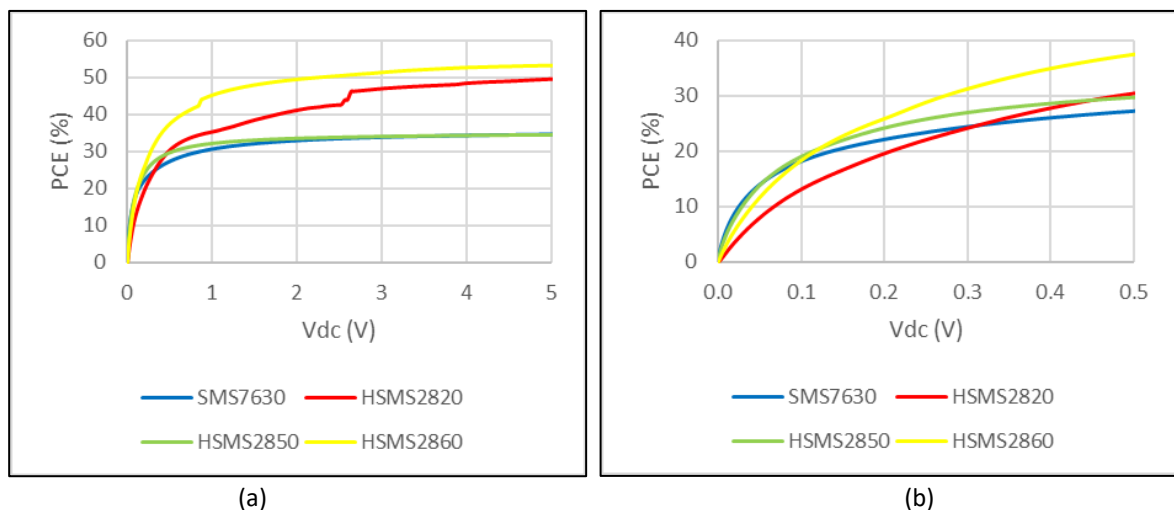

Fig. 5. Single diode in ADS simulation result (a) High input power (b) Low input power

Figure 5(b) show the plot of simulation results for low input power from -30 to 0 dBm, respectively. It can be noticed that HSMS2850 and SMS7630 has a higher PCE for lower power input voltage, as mentioned in [18] the HSMS2850 has a better result in low power application in contrast

to HSMS2860 which shows a better result with higher input power voltage for mathematical model and simulation. Both mathematical and simulation show similar trend on the PCE where HSMS2860 and HSMS2820 is suitable for high input power, while HSMS2850 and SMS7630 are preferable for low power rectifier circuit.

### 3. Voltage Doubler

The basic components of the voltage doubler rectifier topology include two Schottky diodes and two capacitors [16]. The voltage doubler is a single voltage multiplier circuit, where the output is double from the input. The capacitor C1 and C2 active in one of the positive and negative cycle, which double the output voltage. Figure 6(a) shows the simulation circuit of a single voltage doubler with a simple matching network consisting of a shunt capacitor and a series inductor. Unlike a single series or shunt diode topology, the voltage doubler will get a higher PCE as shown in Figure 6(b) because it converts a full wave signal. Figure 6(c) shows the output voltage, roughly twice the input voltage ( $V_{in}$ ), therefore  $V_{out} = 2V_{in}$  [12]. For the proposed circuit, the PCE maximum at 21 dBm input power with PCE of 87%. To increase the output voltage, the voltage doubler stages can be increased and become a voltage multiplier. Depending on the stages the voltage will multiply but losses will increase due to the increased number of components [4].

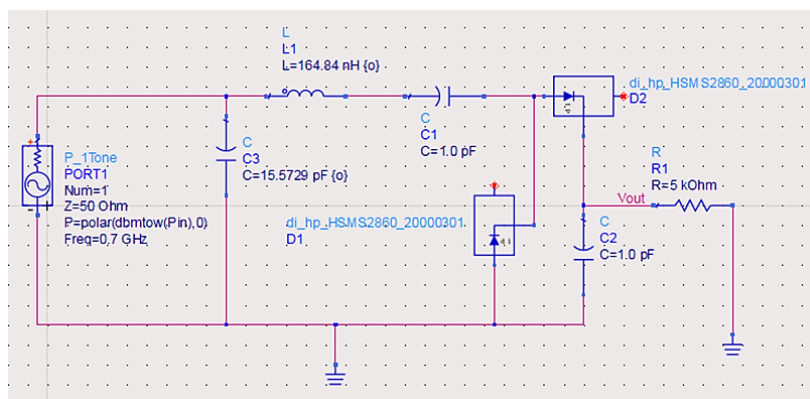

(a)

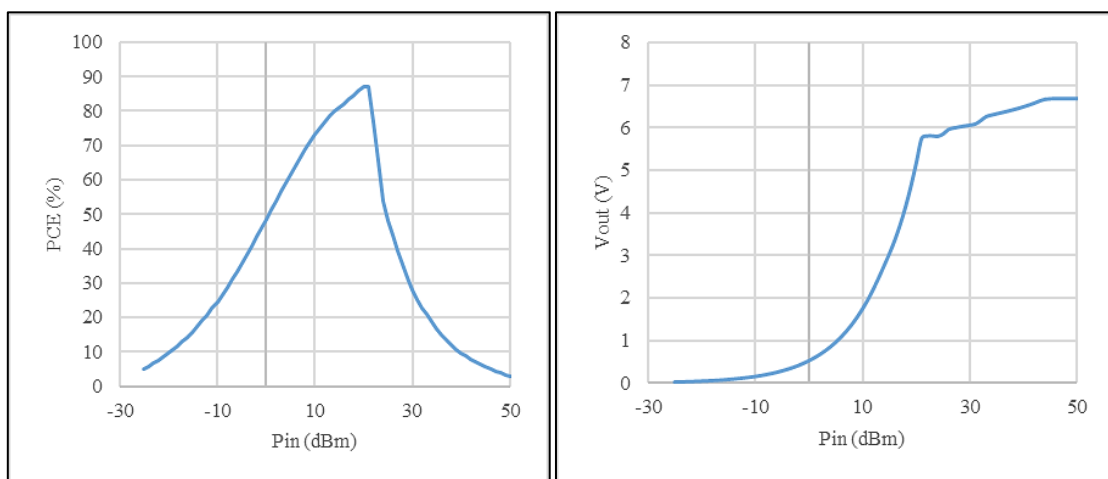

(b)

(c)

**Fig. 6.** (a) Voltage doubler simulated in ADS (b) Power conversion efficiency versus input power (c) Output voltage versus input power

#### 4. Conclusions

RFEH system purpose is to harvest the ambient RF power from RF Energy sources. The diode is an important component of the rectifier circuit and influences the PCE of the rectifier circuit which influences the overall RFEH system quality and effectiveness. In this work, the HSMS2860 Schottky diode is chosen for modeling in ADS. The diode is characterized with I-V curve and efficiency at 700MHz frequency. Next, a mathematical model and simulation model with a single diode configuration is analyzed to determine the input power range suitable for a selected Schottky diodes namely, SMS7630, HSMS2820, HSMS2850, and HSMS2860. The results show that for high input power, HSMS2860 has a PCE of 60% using the mathematical model and 53% using the simulation model. For low input power SMS7630 and HSMS2850 showed a better efficiency result of approximately 20% at 0.1 Vdc. The variation of mathematical and simulation came from some of the spice parameters were neglected during mathematical analysis, plus with the nonlinearity in the diode characteristic and a transmission line has been introduced for impedance matching which introduced additional losses. From the results we can determine the suitable application for the Schottky diode. Additionally, a single stage voltage doubler is simulated using ADS with a simple matching network consisting of a shunt capacitor and a series inductor. Upgrading from a single series or shunt diode topology to voltage doubler produces higher PCE as it covers both positive and negative cycle of input signal. The output voltage of a voltage doubler roughly twice the input voltage if components loss is neglected. Cascading the voltage doubler stages into multiple stage to become a voltage multiplier, can increase the output. Depending on the stages the voltage will multiply but losses will increase due to the increased number of components.

#### Acknowledgement

The author would like to acknowledge the support from the Fundamental Research Grant Scheme (FRGS) under a grant number of FRGS/1/2020/TK0/UNIMAP/02/70.

#### References

- [1] Vu, Hong Son, Ngan Nguyen, Nam Ha-Van, Chulhun Seo, and Minh Thuy Le. "Multiband ambient RF energy harvesting for autonomous IoT devices." *IEEE Microwave and Wireless Components Letters* 30, no. 12 (2020): 1189-1192. <https://doi.org/10.1109/LMWC.2020.3029869>
- [2] Mansour, Mohamed M., Shota Torigoe, Shuya Yamamoto, and Haruichi Kanaya. "Compact and simple high-efficient dual-band RF-DC rectifier for wireless electromagnetic energy harvesting." *Electronics* 10, no. 15 (2021): 1764. <https://doi.org/10.3390/electronics10151764>
- [3] Roy, Sunanda, R. Jun-Jiat Tiang, Mardeni Bin Roslee, Md Tanvir Ahmed, and MA Parvez Mahmud. "Quad-band multiport rectenna for RF energy harvesting in ambient environment." *IEEE access* 9 (2021): 77464-77481. <https://doi.org/10.1109/ACCESS.2021.3082914>
- [4] Mansour, Mohamed M., Shuya Yamamoto, and Haruichi Kanaya. "Reconfigurable multistage RF rectifier topology for 900 MHz ISM energy-harvesting applications." *IEEE Microwave and Wireless Components Letters* 30, no. 12 (2020): 1181-1184. <https://doi.org/10.1109/LMWC.2020.3029252>
- [5] Sathiyapriya, T., V. Gurunathan, T. Vimala, KN Krishna Prasad, and T. Naveen Kumar. "Voltage doubler design for RF energy harvesting system." In *2020 7th International Conference on Smart Structures and Systems (ICSSS)*, pp. 1-4. IEEE, 2020. <https://doi.org/10.1109/ICSSS49621.2020.9201998>
- [6] Divakaran, Sleebi K., Deepti Das Krishna, and Nasimuddin. "RF energy harvesting systems: An overview and design issues." *International Journal of RF and Microwave Computer-Aided Engineering* 29, no. 1 (2019): e21633. <https://doi.org/10.1002/mmce.21633>
- [7] Elsheakh, Dalia, Mina Farouk, Hala Elsadek, and Hani Ghali. "Quad-band rectenna for RF energy harvesting system." *Journal of Electromagnetic Analysis and Applications* 12, no. 5 (2020): 57-70. <https://doi.org/10.4236/nm.2024.153010>

- [8] Liu, Wenbo, Kama Huang, Tao Wang, Zhuoyue Zhang, and Jing Hou. "A broadband high-efficiency RF rectifier for ambient RF energy harvesting." *IEEE Microwave and Wireless Components Letters* 30, no. 12 (2020): 1185-1188. <https://doi.org/10.1109/LMWC.2020.3028607>
- [9] He, Zhongqi, and Changjun Liu. "A compact high-efficiency broadband rectifier with a wide dynamic range of input power for energy harvesting." *IEEE Microwave and Wireless Components Letters* 30, no. 4 (2020): 433-436. <https://doi.org/10.1109/LMWC.2020.2979711>
- [10] Tissier, Jérôme, Mohsen Koohestani, and Mohamed Latrach. "A comparative study of conventional rectifier topologies for Low Power RF Energy Harvesting." In *2019 IEEE Wireless Power Transfer Conference (WPTC)*, pp. 569-572. IEEE, 2019. <https://doi.org/10.1109/WPTC45513.2019.9055578>
- [11] Mouapi, Alex, Nadir Hakem, and Nahi Kandil. "Performances comparison of Shottky voltage doubler rectifier to support RF energy harvesting." In *2020 IEEE International Conference on Environment and Electrical Engineering and 2020 IEEE Industrial and Commercial Power Systems Europe (EEEIC/I&CPS Europe)*, pp. 1-5. IEEE, 2020. <https://doi.org/10.1109/EEEIC/ICPSEurope49358.2020.9160511>
- [12] Selim, Kyrillos K., Shaochuan Wu, Demyana A. Saleeb, and Sherif SM Ghoneim. "A quad-band rf circuit for enhancement of energy harvesting." *Electronics* 10, no. 10 (2021): 1160. <https://doi.org/10.3390/electronics10101160>
- [13] Roy, Sunanda, Jun Jiat Tiang, Mardeni Bin Roslee, Md Tanvir Ahmed, Abbas Z. Kouzani, and MA Parvez Mahmud. "Quad-band rectenna for ambient radio frequency (RF) energy harvesting." *Sensors* 21, no. 23 (2021): 7838. <https://doi.org/10.3390/s21237838>
- [14] Muhammad, Surajo, Jun Jiat Tiang, Sew Kin Wong, Amjad Iqbal, Mohammad Alibakhshikenari, and Ernesto Limiti. "Compact rectifier circuit design for harvesting GSM/900 ambient energy." *Electronics* 9, no. 10 (2020): 1614. <https://doi.org/10.3390/electronics9101614>
- [15] DeLong, Brock J., Asimina Kiourti, and John L. Volakis. "A radiating near-field patch rectenna for wireless power transfer to medical implants at 2.4 GHz." *IEEE Journal of Electromagnetics, RF and Microwaves in Medicine and Biology* 2, no. 1 (2018): 64-69. <https://doi.org/10.1109/JERM.2018.2815905>
- [16] Park, Hong Soo, and Sun K. Hong. "Broadband RF-to-DC rectifier with uncomplicated matching network." *IEEE Microwave and Wireless Components Letters* 30, no. 1 (2019): 43-46. <https://doi.org/10.1109/LMWC.2019.2954594>
- [17] Çelik, Kayhan, and Erol Kurt. "Design and implementation of a dual band bioinspired leaf rectenna for RF energy harvesting applications." *International Journal of RF and Microwave Computer-Aided Engineering* 31, no. 11 (2021): e22868. <https://doi.org/10.1002/mmce.22868>
- [18] Ishibashi, Koichiro, Jiro Ida, Linh-Thuy Nguyen, Ryo Ishikawa, Yasuo Satoh, and Duy-Manh Luong. "RF characteristics of rectifier devices for ambient RF energy harvesting." In *2019 International Symposium on Electronics and Smart Devices (ISESD)*, pp. 1-4. IEEE, 2019. <https://doi.org/10.1109/ISESD.2019.8909660>
- [19] Al-Absi, Munir A., and Sami R. Al-Batati. "Hybrid internal Vth cancellation rectifiers for RF energy harvesting." *IEEE Access* 8 (2020): 51976-51980. <https://doi.org/10.1109/ACCESS.2020.2980080>
- [20] Wagih, Mahmoud, Nicholas Hillier, Sheng Yong, Alex S. Weddell, and Steve Beeby. "RF-powered wearable energy harvesting and storage module based on E-textile coplanar waveguide rectenna and supercapacitor." *IEEE Open Journal of Antennas and Propagation* 2 (2021): 302-314. <https://doi.org/10.1109/OJAP.2021.3059501>