



Fuzzy Logic Controller- Proportional-Integral for Motor Velocity Control of Electric Rail Train Using DC-DC Converter

Rustam Asnawi^{1,*}, Moh. Khairudin^{1,*}, Istanto Wahyu Djatmiko¹, Nurhening Yuniarti¹, Sigit Yatmono¹, Toto Sukisno¹, Eko Swi Damarwan¹, Alex Sandria Jaya Wardhana¹, Hartoyo¹, Setio Wati Miladiah¹, Rizqi Ervani², Muhammad Minto Aji Shodiq¹, Fitriana Kusuma¹, Ade Pangelasan¹, Thoriq Fadlurrohman Huda¹, Andika Wicaksana¹, Asnan Munandar¹, Salma Fauziyah Nur¹, Wan Azani Mustafa³

¹ Department of Electrical Engineering, Faculty of Engineering, Universitas Negeri Yogyakarta, 55281, Yogyakarta, Indonesia

² PT. Rekaindo Global Jasa, Madiun, Jawa Timur, Indonesia

³ Advanced Computing Engineering, Centre of Excellence, Universiti Malaysia Perlis, Pauh Putra Campus, 02600 Arau, Perlis, Malaysia

ARTICLE INFO

Article history:

Received 23 January 2024

Received in revised form 23 October 2024

Accepted 5 November 2024

Available online 15 December 2024

Keywords:

DC motor; DC chopper; Fuzzy logic controller proportional integral (FLC-PI)

ABSTRACT

DC motor utilization is obtained in various of industrial activities and non- industrial activities. The utilization of DC motors in various purposes, it is necessary to control a velocity of the DC motor in accordance with a required velocity and this control can be conducted through a power converter. In this study, the utilization of DC chopper for velocity control of DC motor through Fuzzy logic controller proportional integral (FLC-PI) method for electric rail train is developed. The FLC-PI supports to achieve an adaptive controller. It has been adapted to achieve a good performance for auto tuning PI controller. The development process is conducted through simulation work with Matlab software. This study compares the performance between the system with PI control and FLC-PI control. The results of this study obtained the comparison between the PI and FLC-PI performances for the system without load are 1.06% and 0% overshoots respectively. In other to the comparison between the PI and FLC-PI performances for the system with load of 100 Nm are 0.5% and 0% overshoots respectively. And when the comparison between the PI and FLC-PI performances for the system with load of 200 Nm are 0.27% and 0% overshoots respectively. Thus, FLC-PI has shown more better performance than PI control.

1. Introduction

Electric railway train (KRL) is a fleet for transporting train-type passengers with an energy source using electric power [1, 2]. The operational and driving process of KRL is independent and does not require a locomotive as a puller. KRL is a train that moves based on an electrification system. The

* Corresponding author.

E-mail address: rustam@uny.ac.id

* Corresponding author.

E-mail address: moh_khairudin@uny.ac.id

<https://doi.org/10.37934/araset.54.1.6279>

electrification system on the KRL flows electrical energy to the train locomotive and several other carriage units so that the train can run [3, 4]. KRL is a means of railroad that has its own drive in the form of motor traction. Motor traction is installed on each axle through a gear box on a motor car (MC) train using an electric power source [5, 6]. The electrical power needed by the KRL comes from a traction substation using a conductor wire that runs at the top along the KRL route. The electrical power source on the upper track of the KRL is called the catenary system or overhead catenary system [6]. To channel the power source to KRL, a device called pantograph is used. Pantograph is used as a KRL electricity flow to the converter which is connected to the traction motor so that KRL can move. KRL uses a voltage source of 1500 VDC as a working voltage with a supply from PLN of 20 KVAC which will then undergo several processes to DC working voltage [5].

The catenary system is a transmission medium for distributing voltage from the traction substation to the KRL. The electrification of the KRL line uses DC voltage, the preference for DC motors is based on safety, efficiency, and economic benefits. The pantograph, overhead catenary system is the main system in track electrification. The catenary is at the top center of the track and the pantograph is mounted on the roof of the train [1].

In the early development of KRL, DC motors were predominantly used because they could be easily adjusted. The classic way of regulating DC motors on KRL is by limiting the voltage entering the DC motor using a rheostat so that the velocity of the DC motor can be adjusted [7, 8]. Low efficiency due to rheostat and the development of static switch technology (thyristor) resulted in this method no longer being used.

Currently, to regulate the DC voltage on the KRL DC motor, a DC-DC converter or often called a DC chopper is used as shown in Figure 1 [9-11]. With DC-DC converters, voltage regulation is easier, and efficiency will be better. The use of DC-DC converters began in the 70s of KRL [12-14]. In DC-DC, commutators, brushes, and split rings are something that must exist. Unfortunately, many ground faults occur when the commutator contacts the brushes at high rotational velocities. This is one of the reasons for using AC motors in KRL [15]. Block diagram of DC motor armature control system is shown in Figure 2.

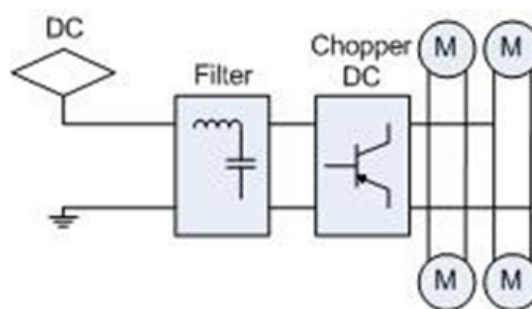

Fig. 1. DC motor drive system

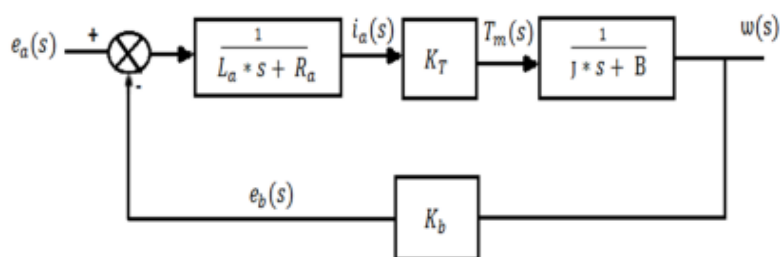

Fig. 2. Block diagram of DC motor armature control system

DC motor is one type of motor whose application is relatively easy; therefore, DC motors are often used in various types of activities [16-18]. DC motors have two main terminals, namely input terminals and output terminals that require direct current voltage to be able to drive them [19, 20]. To fulfill these various needs, of course, it is necessary to control the velocity of the DC motor in accordance with the required velocity [21, 22]. A velocity of the DC motor can be adjusted by increasing and decreasing the amount of field current or armature current coming from the motor and controlling this current can be conducted through a power converter, namely by adjusting the voltage on the DC motor [23, 24]. Power converters commonly used in DC motor velocity control include DC chopper and controlled rectifier. In this study only focuses on the use of DC chopper, which is a device that functions to convert DC voltage into DC voltage that can be changed (variable). DC to DC Converter or commonly referred to as DC chopper is used mainly in providing DC output voltage whose magnitude varies according to the load used [23].

The input power from the DC source is obtained from the traction substation through the overhead catenary which has a constant input voltage (fixed) [25, 26]. To get the desired DC output voltage, one way is to adjust the length of time between the input side and the output side in the same circuit [27, 28]. In this study, a DC chopper is proposed to control the velocity of DC motor by using the Proportional Integral (PI) method which is automatically tuned with a Fuzzy Logic Controller (FLC) on an electric rail train. This study is conducted by simulation work through Simulink MATLAB. The PI control method is designed to be able to fix the error value that is usually found between the predetermined set point value and the feedback value [16]. The combination of proportional and integral controllers is useful to accelerate the reaction that works on a system and eliminate the possibility of steady errors (offset) [15].

However, there are weaknesses in the PI control system. The weakness is that the tuning of the P and I parameter values is still conducted manually. Therefore, an automatic tuning system for PI control is needed. In this study, a fuzzy control system is developed for automatic tuning of PI control. Fuzzy logic control (FLC) systems can be used to control a process even though the system does not have a mathematical model [29-31]. Another advantage of fuzzy controllers is that they can be easily tuned by users for tuning automatically [32, 33]. In this study, a control system is developed for four DC motors assembled in series. Another work proposed sensor less control is to improve velocity control performance and robustness of synchronous motor drive under load variations with FLC [32]. The PI and adaptive neuro-fuzzy inference system (ANFIS) controllers were designed and compared for BLDC motor in electric vehicles applications [33].

This study develops an FLC-PI to control the velocity of four DC motors that assembled with series. Refers to the previous studies a few conducted on FLC for only a DC motor. Compared to the previous studies, this study has challenges on controlling DC motors with FLC-PI control. The FLC control in this study tuned the PI parameters. Also, this study has the contribution compared to the previous studies that this study is the testing of DC motor control systems without and with various loads. This study conducted performances comparison with and without load for four DC motor for representing to the real experimental work for DC motors control to drive an Electric Rail Trains. The loads on DC motors of Electric Rail Trains consist of without load, lower load, till to the highest load. Assembling the four DC motors with series circuits also the challenges of this study compared to the previous studies.

2. Methodology

2.1 DC Motor Velocity Controller Circuit Configuration

DC motor armature control system presets in Figure 2. The transfer function of DC motor can be seen on Eq. (1).

$$\frac{\omega(s)}{e_a(s)} = \frac{K_T}{(L_a * s + R_a)(J * s + B) + K_T * K_b} \quad (1)$$

The control system or direct motor velocity controller using a Proportional Integral (PI) control method based on the DC chopper circuit proposed in this study was assessed through MATLAB Simulink simulation with the model as shown in Figure 3. This simulation uses four DC motors with a separate amplifier of 375 VDC as a load with a series circuit. Figure 3 describes a direct motor control system with a DC chopper that is given a voltage sensor, current sensor, velocity sensor, and a scope that serves to display the results of running simulations.

Figure 3 presents the DC-DC converters supplying the drive power therefore may be unregulated types if the input to the DC-DCs is nominally constant. Unlike most applications for DC-DCs however, the load is quite constant when the IGBT is switching at any duty cycle. Alternatively, the load is close to zero when the IGBT is not switching. Simple DC-DCs often need a minimum load otherwise their output voltages can dramatically increase, possibly up to the gate breakdown level. This high voltage is stored on the positive bulk capacitor so that when the IGBT starts to switch, it could see a gate overvoltage until the level drops under normal load. A DC-DC should be chosen therefore that has clamped output voltages or zero minimum load requirements. IGBTs should not be actively driven by PWM signals until the drive circuit voltage rails are at correct values. However, as gate drive DC-DCs are powered up or down, a transient condition might exist where IGBTs could be driven on, even with the PWM signal inactive, leading to shoot-through and damage. The DC-DC should therefore be well behaved with short and monotonic rise and fall times. A primary referenced on-off control can enable sequencing of power-up of the DC-DCs in a bridge reducing the risk of shoot-through.

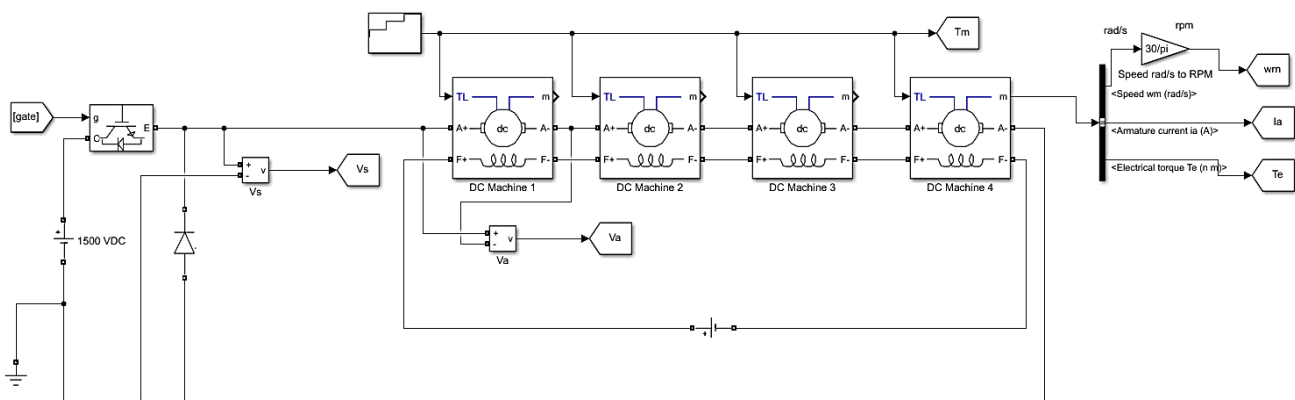

Fig. 3. DC Chopper circuit with four series DC motor

DC chopper is commonly called a traction inverter. The DC chopper has a function to rotate or drive a traction motor. DC chopper works by converting DC voltage into DC voltage that can be controlled. In this study, the DC chopper scheme used consists of Insulated Gate Bipolar Transistor (IGBT), diode, and inductor. Based on the operating system on electric rail trains, the input power source is obtained from the traction substation which is channeled through the overhead catenary system. Then the DC source is channeled again through the pantograph which then the input voltage

will be adjusted. This input voltage regulation (DC to DC) is controlled by a DC chopper control circuit as shown in Figure 3. Table 1 presents the DC motor specifications for this study.

Table 1
 The DC motor specifications

Symbol	Parameter	Value	Unit
R_a	Armature resistance	0.5	ohms
L_a	Armature inductance	0.01	H
R_f	Field resistance	75	ohms
L_f	Field inductance	0.02	H
L_{af}	Field armature mutual inductance	0.2641	H
J	Total inertia	0.4	kg.m ²
B_m	Viscous friction coefficient	0.02516	N.m.s
T_f	Coulomb friction torque	2.646	N.m
v	Initial speed	1	rad/s

2.2 PI Controller (Ziegler- Nichols Method)

PI control has been implemented on the DC motor velocity. PI controller is mainly to improve an appropriate proportional gain (K_p) and integral gain (K_i) for achieving the optimal control performance. The relationship between the output $u(t)$ and input $e(t)$ can be formulated on Eq. (2).

$$u(t) = K_p e(t) + K_i \int_0^t e(t) dt \tag{2}$$

Figure 4 explains the block diagram of the Proportional Integral control system used in this study. Ziegler- Nichols is a type of continuous cycling method for controller tuning. Furthermore, the PI control system will be tuned automatically using a Fuzzy Logic Controller (FLC).

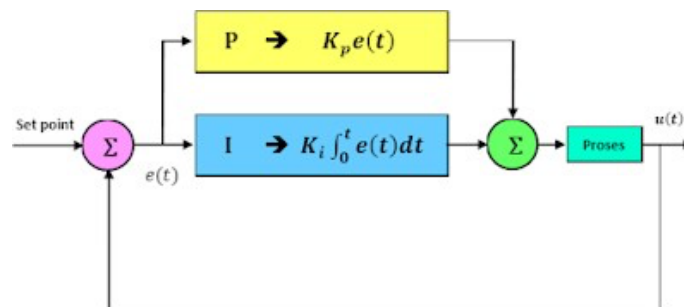

Fig. 4. PI control block diagram

PI controller control is a standard control commonly used to check if there is an error between the measurement value obtained and the deviation. The PI control method is designed to be able to fix the error value that is usually found between the predetermined set point value and the feedback value. The combination of Proportional and Integral controllers is useful for accelerating the reaction that works on a system and eliminating the possibility of steady errors (offset). A PI control that conveys control action proportional (equivalent) to the total error will have a positive effect in reducing the error, but the opposite will cause a worse transient response.

Figure 5 is the PI control circuit used in this DC chopper-based DC motor velocity controller circuit configuration.

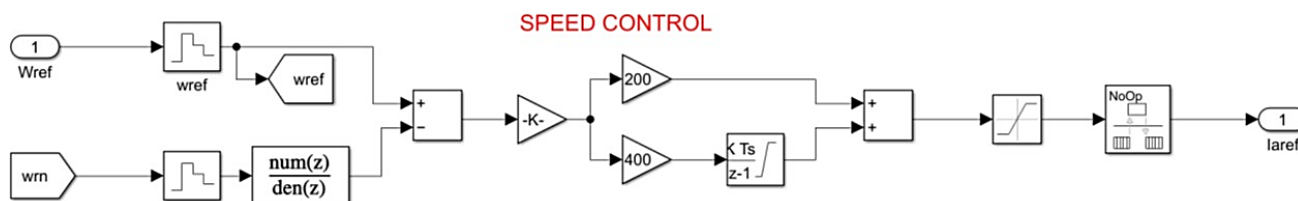

Fig. 5. PI controller circuit for DC chopper

Difficulty in tuning these parameters will be encountered if the plant is being controlled with a complex system. Therefore, a better PI tuning method is necessary that can be applied in four DC motors with series circuits. The PI tuning method with fuzzy logic controller can be conducted in this study and called FLC-PI. In this method the values of K_p and K_i are determined based on number of rules determined by FLC. FLC input in the form of error and delta error. The FLC-PI method was able to produce results output response with faster rise time, small steady-state error, and small overshoot.

In electric rail trains, DC motors are predominantly used because they are easy to set up. The classic way to regulate a DC motor electric rail train is to limit the input voltage of the DC motor. In this study, a switching used is IGBT in order to the velocity of the DC motor can be controlled. To control the DC voltage on the DC motor of electric rail trains, used a DC Chopper as a DC-DC converter. DC Chopper is a converter whose function is to change DC to DC voltages by changing the magnitude of the DC voltage. With a DC-DC converter, voltage regulation is easier and more efficient.

2.3 Fuzzy Logic Controller-Proportional Integral Control Design

FLC input in the form of error and delta error. Error and delta error can be formulated on Eq. (3).

$$de = e(t) - e(t - 1) \tag{3}$$

FLC control design begins with the step of determining the membership function for the input and output circuits. In this study, the method used in the design of FLC is Sugeno method. The difference between Sugeno's method and other methods is the output value in the form of variable quantities, not in the form of membership functions. FLC design is conducted through several steps. These steps consist of (1) determination of fuzzification, (2) membership function grouping for input and output, (3) determination of rules used, and (4) determination of defuzzification.

The input for the Self-tuning FLC-PI controller is error $e(t)$ and change of error $de(t)$ as taken in Eq. (3). Through FLC-PI controller rules on-line, the PI parameters will be adjusted. The gains parameters K_p and K_i are finalized and optimized automatically. It composes a self-tuning FLC-PI controller, the block diagram of FLC-PI controller can be seen in Figure 6.

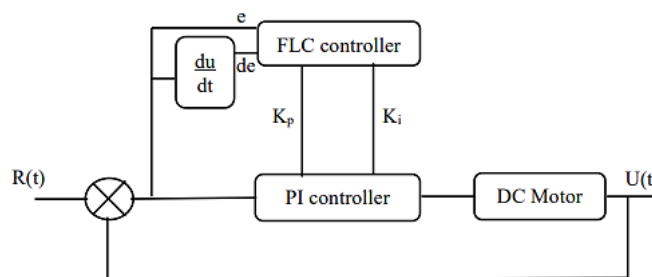

Fig. 6. The schematic of self-tuning FLC-PI controller

FLC supports an auto tuning of PI control can be seen at Figure 7. It provides better performance compared to standalone PI or FLC. Simple rule base is applied for FLC while FLC-PI uses different rule base for proportional and integral gains to improve response faster.

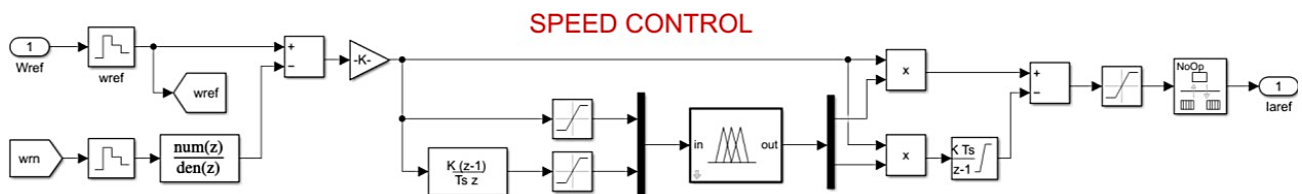

Fig. 7. FLC-PI controller for DC motor based on DC chopper

The initial process carried out is the determination of fuzzification. Fuzzification in question is the grouping of input and output value parameters so that they are more varied. The fuzzification process of the input and output circuits can be seen in Figure 8.

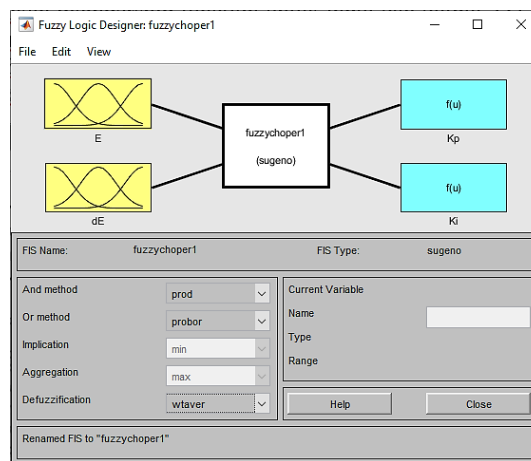

Fig. 8. FLC-PI design

For the input circuit consists of two types, namely error (e) and delta error (de). Meanwhile, the output circuit consists of proportional constants (K_p) and integral constants (K_i). The input circuit with membership function design for variable error consists of five membership functions. The division of membership functions for input on variable error can be seen in Figure 9. While the input circuit with membership function design for variable delta error consists of three membership functions. The division of membership functions for input on the delta error variable can be seen in Figure 10.

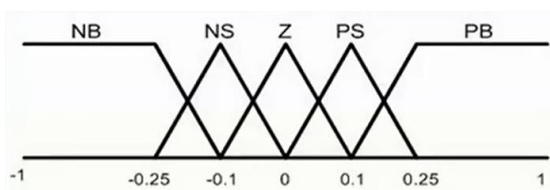

Fig. 9. MF design on error



Fig. 10. MF design on delta error

Figure 9 shows that the input with variable error consists of five membership functions namely NB (Negative Big), NS (Negative Small), Z (Zero), PS (Positive Small), and PB (Positive Big). While Figure 10 shows that the input with the delta error variable consists of three membership functions namely N (Negative), Z (Zero), and P (Positive).

As for the output circuit consists of two types, namely K_p and K_i as shown in Table 2. In the output circuit with membership function design for variable K_p consists of three membership functions. The division of the membership function for output on the K_p variable can be seen in Table 2(a). While the output circuit with membership function design for variable K_i consists of five membership functions. The division of the membership function for output on the K_i variable can be seen in Table 2(b).

Table 2
 Output circuit of K_p and K_i

Linguistic	Crisp
(a) Output1 (K_p)	
Big (B)	260
Medium (M)	250
Small (S)	240
(b) Output2 (K_i)	
Very Big (B)	425
Big (B)	420
Medium (M)	415
Small (S)	410
Very	405

The next step is to determine the rules for the relationship process between two inputs and two outputs that have been designed. In this study, 15 rules have been compiled with the AND scheme. The rule design in this study can be seen in Figure 11. Meanwhile, Figure 12 shows the surface of the rules that have been compiled with the distribution of input and output characters.

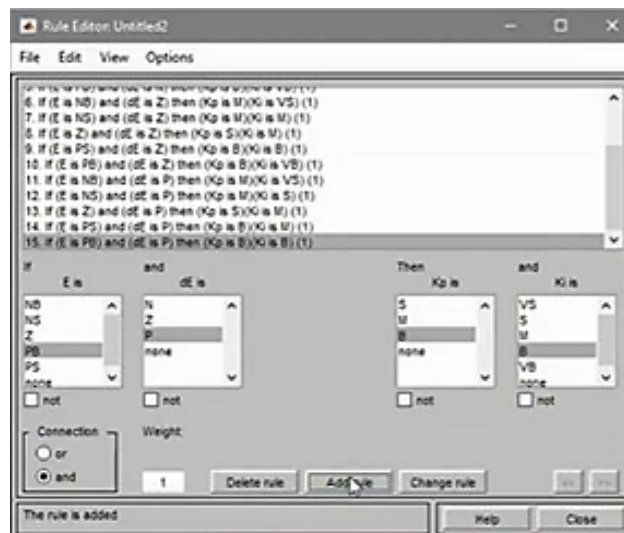

Fig. 11. Determination of rules

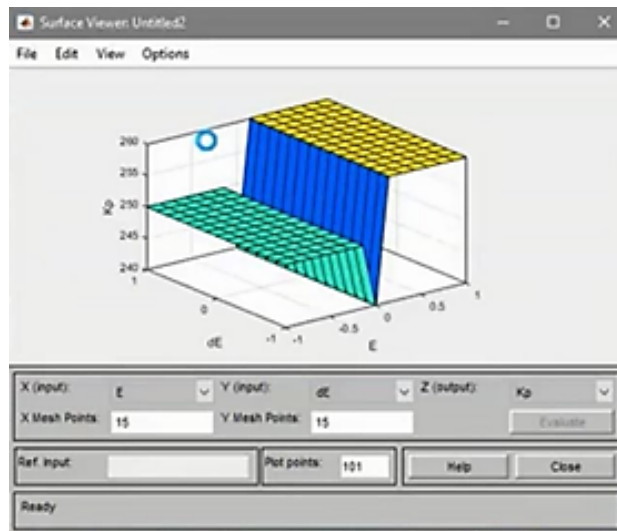

Fig. 12. Surface rules

The result and the rules that used in the FLC-PI method are as shown in Table 3.

Table 3
 Rule in FLC-PI design

No	Rules
1	If (E is NB) and (dE is N) then (K_p is M) (K_i is S)
2	If (E is NS) and (dE is N) then (K_p is M) (K_i is M)
3	If (E is Z) and (dE is N) then (K_p is S) (K_i is B)
4	If (E is PS) and (dE is N) then (K_p is B) (K_i is VB)
5	If (E is PB) and (dE is N) then (K_p is B) (K_i is VB)
6	If (E is NB) and (dE is Z) then (K_p is M) (K_i is VS)
7	If (E is NS) and (dE is Z) then (K_p is M) (K_i is M)
8	If (E is Z) and (dE is Z) then (K_p is S) (K_i is M)
9	If (E is PS) and (dE is Z) then (K_p is B) (K_i is B)
10	If (E is PB) and (dE is Z) then (K_p is B) (K_i is VB)
11	If (E is NB) and (dE is P) then (K_p is M) (K_i is VS)
12	If (E is NS) and (dE is P) then (K_p is M) (K_i is S)
13	If (E is Z) and (dE is P) then (K_p is S) (K_i is M)
14	If (E is PS) and (dE is P) then (K_p is B) (K_i is M)
15	If (E is PB) and (dE is P) then (K_p is B) (K_i is VB)

Based on the rules that have been designed, it can be seen the distribution of input and output characters for variable error, delta error, K_p and K_i .

3. Result and Discussions

Power converters commonly used to control DC motor velocity include DC choppers and controlled rectifiers. This study focuses on the use of a DC chopper, which is a subsystem that functions to convert DC to DC voltage that can be changed. DC to DC Converter or what is usually called a DC chopper is used mainly to provide DC output voltage whose magnitude varies according to the load used.

Input power from a DC source is obtained from the traction substation via upper channel electricity which has a constant input voltage. To obtain the desired DC output voltage, one technique is to adjust the length of connection time between the input and the output sides in the same circuit.

This study proposes a DC chopper to control the velocity of a DC motor using the FLC-PI method on electric rail trains.

3.1 DC Motor Output Results Without Load

The first experiment was conducted by giving a load value of 0 Nm to the circuit and using a 1500 VDC Vref reference voltage input. The differences obtained when the circuit uses PI control and FLC-PI control are in settling time, armature current, DC motor rotation velocity (rpm), overshoot value, and the resulting RMS voltage. The comparison of PI and FLC-PI control system performance for DC Chopper when it is unloaded as shown in Table 4.

Table 4
 Without load DC motor output data with PI and FLC-PI control

	PI control	FLC-PI control
Settling time (s)	0.273	0.269
Anchor current (A)	5.78	5.903
DC motor rotation velocity (rpm)	1895	1872
Overshoot (%)	1.06	0
Vrms (v)	Total vrms: 1053 Vrms per motor: 263.2	Total vrms: 1041 Vrms per motor: 265.2

The system without load used PI control scheme briefs with the settling time and overshoot of 0.273 s and 1.06% respectively and the maximum velocity of the DC motor is 1895 rpm. Otherwise FLC- PI control performs with a settling time and overshoot are 0.269 s and 0% respectively and the maximum motor rotation velocity of 1872 rpm. Performances comparison between the system with PI and FLC-PI control can be seen in Figure 13 to Figure 17.

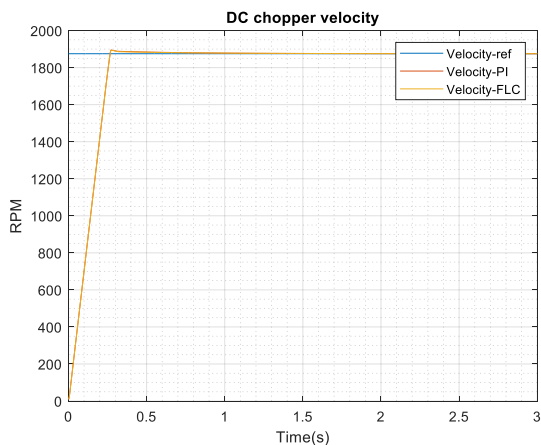

Fig. 13. Velocity performance without load

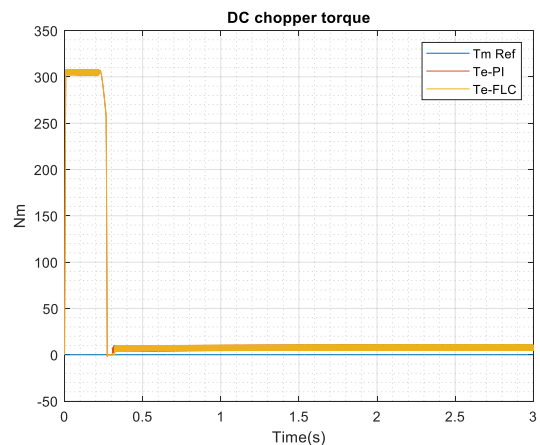

Fig. 14. Torque performance without load

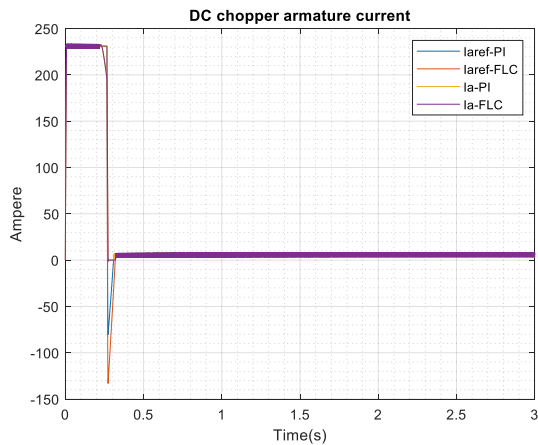

Fig. 15. Armature Current performance without load

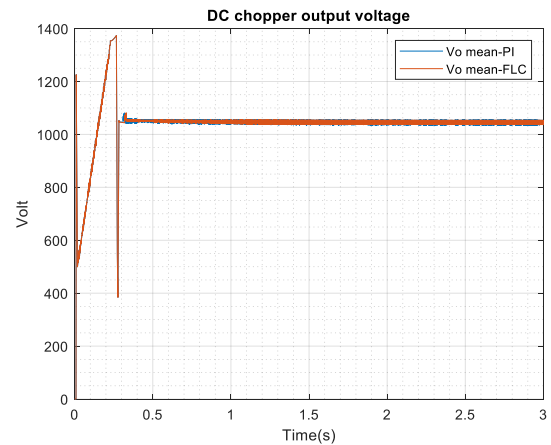

Fig. 16. Output voltage performance without load

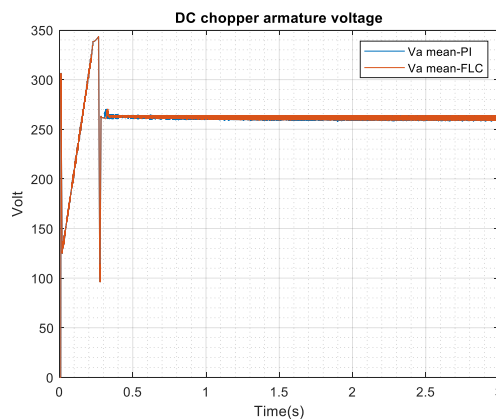

Fig. 17. Armature voltage performance without load

3.2 DC Motor Output Results With 100 Nm Load

This study also conducted by giving a load of 100 Nm to the system and using a 1500 VDC Vref reference voltage input. The differences obtained when the system uses PI and FLC-PI control are performed in settling time, armature current, DC motor rotation velocity, overshoot, and the resulting RMS voltage. The comparison of PI and FLC-PI control system performance for DC Chopper with load of 100 Nm can be seen at Table 5. It can be concluded that FLC-PI control performs more better compared to PI control with the performances of lower in settling time, Anchor current, velocity, overshoot, and Vrms.

Table 5

DC motor output data (100 Nm) with PI and FLC-PI control

	PI control	FLC-PI control
Settling time (s)	0.415	0.402
Anchor current (A)	82.34	81.77
DC motor rotation velocity (rpm)	1885	1860
Overshoot (%)	0.5	0
Vrms (v)	Total vrms: 1200 Vrms per motor: 299.8	Total vrms: 1189 Vrms per motor: 297.3

The system with load of 100 Nm used PI control scheme performs a settling time and overshoot are 0.415 s and 0.5% respectively, and the maximum velocity of the DC motor is 1885 rpm. While the

system used FLC- PI can achieve the responses with settling time and overshoot of 0.402 s and 0% respectively and obtained maximum motor rotation velocity of 1860 rpm. The comparison between the system with PI and FLC-PI control for the system with load of 100 Nm can be seen in Figure 18 to Figure 22.

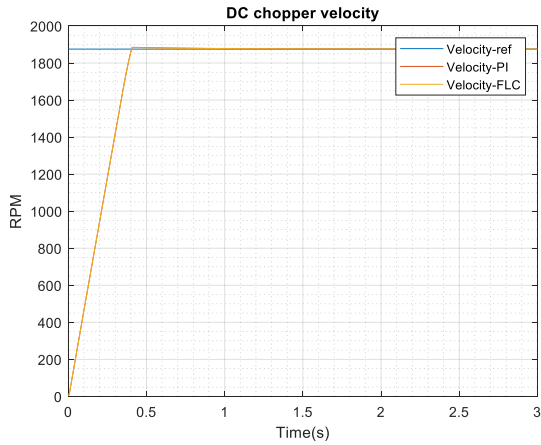

Fig. 18. Velocity performance with load of 100 Nm

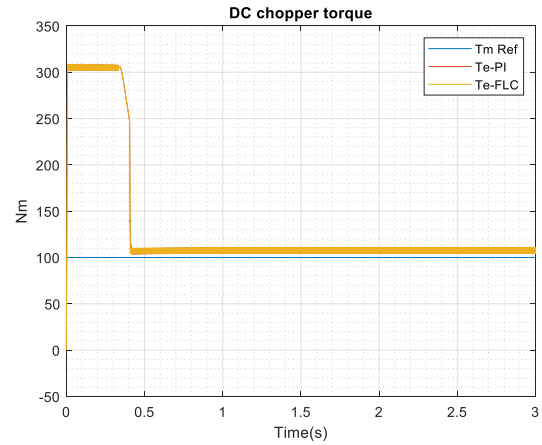

Fig. 19. Torque performance with load of 100 Nm

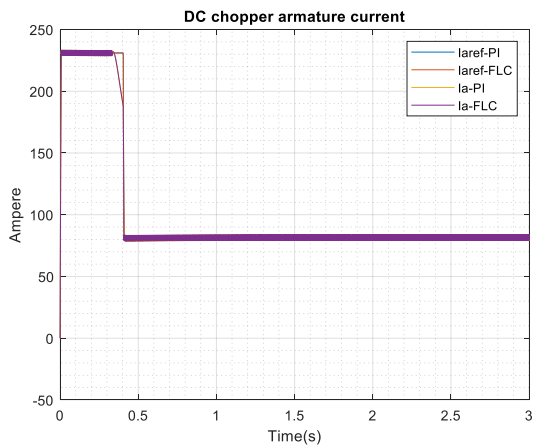

Fig. 20. Armature Current performance with load of 100 Nm

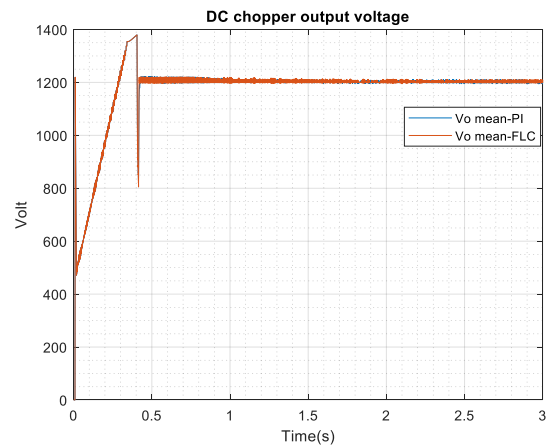

Fig. 21. Output voltage performance with load of 100 Nm

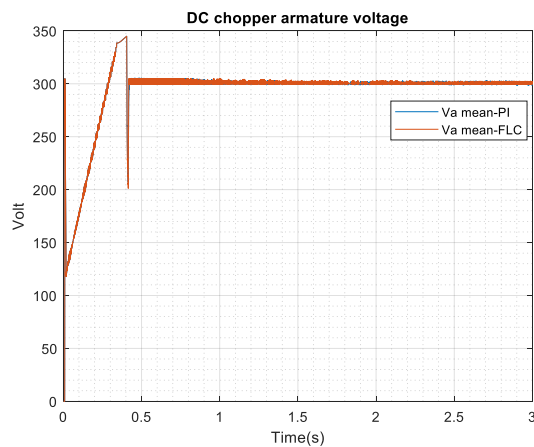

Fig. 22. Armature voltage performance with load of 100 Nm

3.3 DC Motor Output Results With 200 Nm Load

This study also conducted by giving a load of 200 Nm to the system and using a 1500 VDC Vref reference voltage input. The differences obtained when the system uses PI and FLC-PI control are presented in settling time, armature current, DC motor rotation velocity, overshoot, and the resulting RMS voltage. The comparison of PI and FLC-PI control system performance for DC Chopper with the load of 200Nm can be seen in Table 6.

Table 6
 DC Motor Output Data (200 Nm) with PI Control and FLC-PI Control

	PI control	FLC-PI control
Settling time (s)	0.878	1.773
Anchor current (A)	158.0	158.0
DC motor rotation velocity (rpm)	1880	1855
Overshoot (%)	0.267	0
Vrms (v)	Total vrms: 1348 Vrms per motor: 337.0	Total vrms: 1338 Vrms per motor: 334.2

The system with the load of 200 Nm with the PI control can achieve the performances with the settling time and overshoot of 0.878 s and 0.267% respectively, and the maximum velocity of the DC motor is 1880 rpm. While the system used the FLC-PI presents the performances with the settling time and overshoot of 1.733 s and 0% respectively and obtained the maximum motor rotation velocity of 1855 rpm. The comparison between the system with PI control and FLC-PI control can be seen in Figure 23 to Figure 27.

The Vrms of the system with PI control is proportional to the increasing load. This also achieved to the Vrms value in the circuit using FLC-PI control is directly proportional to the increasing load. In the circuit that uses PI control and FLC-PI control, it appears that the output voltage is a direct output voltage produced has a definite value, and a stable current. It does not interfere with the value of the power supply in the system. Therefore, by using PI control and FLC-PI control, the control of the DC motor velocity will show a more stable responses and improving the system in accordance with the predetermined system specifications.

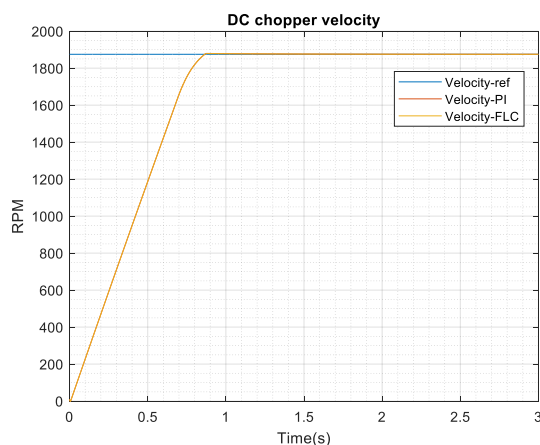

Fig. 23. Velocity performance with load of 200 Nm

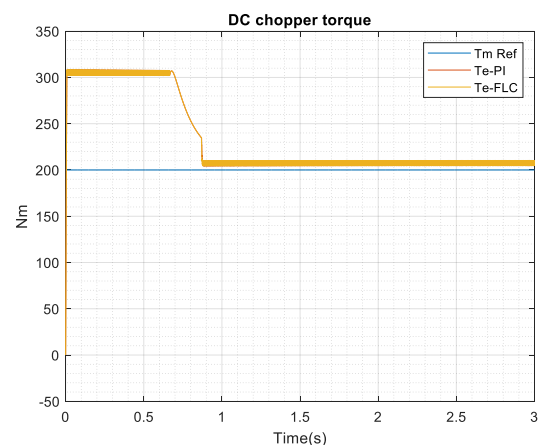

Fig. 24. Torque performance with load of 200 Nm

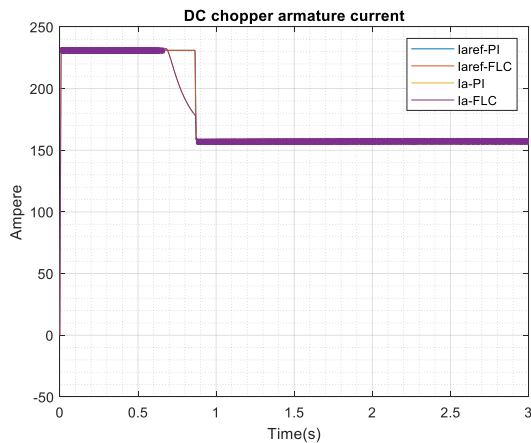

Fig. 25. Armature Current performance with load of 200 Nm

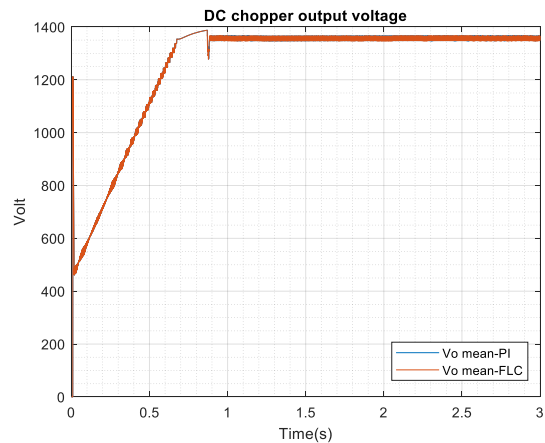

Fig. 26. Output voltage performance with load of 200 Nm

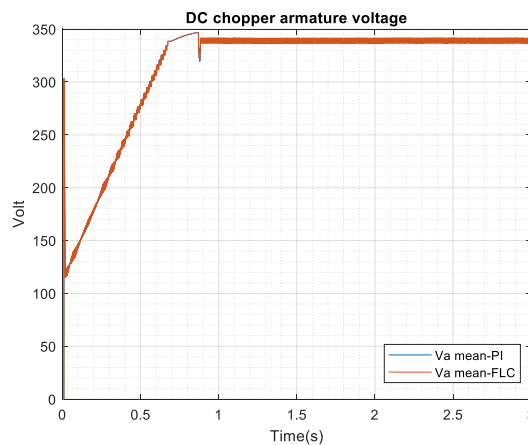

Fig. 27. Armature voltage performance with load of 200 Nm

Accordingly, it was assessed and confirmed, that the DC Chopper within various payload conditions, a common system performance is accomplished with the FLC-PI controller. Note that through comprehensive efforts in comparing to FLC-PI and PI controllers. The method, however, is hard and must be carried out for each loading condition.

Regarding Table 4 to Table 6 and Figure 13 to Figure 27 can be concluded as Table 7 presents for all cases, that the settling time with the FLC-PI control is lessened to almost smaller of the deflection with PI control schemes. Furthermore, with the FLC-PI control, the overshoot match to zero faster contrasted to PI control schemes. The settling time responses of the system uses FLC-PI control scheme with payload of 100 Nm 200 Nm are 0.402 s and 1.773 s, respectively. It is noted for increasing the number of load will impact with increasing the settling time responses.

Table 7
 Comparison performances of DC chopper with various load

Load	Settling time (s)		Anchor current (A)		Rotation velocity (rpm)		Overshoot (%)		Total Vrms (v)	
	PI	FLC-PI	PI	FLC-PI	PI	FLC-PI	PI	FLC-PI	PI	FLC-PI
Without	0.273	0.269	5.78	5,903	1895	1872	1.06	0	1053	1041
100 Nm	0.415	0.402	82.34	81.77	1885	1860	0.5	0	1200	1189
200 Nm	0.878	1.773	158.0	158.0	1880	1855	0.267	0	1348	1338

The performances comparison of the control schemes show that the FLC-PI control strategies presents better than the PI control schemes in reducing the settling of velocity of the DC Chopper. Moreover, in terms of the settling time, FLC-PI performs in without overshoot for without payload and faster settling times as contrasted to PI schemes. The FLC-PI controller could be achieving a similar profiles by comprehensive effort, although for every loading condition it is involves arduous tuning effort. This was completed by comparing the without and with load. The findings indicate that the suggested controller delivers excellent performance of the actual DC Chopper responses. Thus, confidence in the accuracy of the proposed controller for utilization in subsequent investigations for the performance responses for DC Copper systems, has been established. Moreover, in terms of the total Vrms performances, FLC-PI can achieve more lower Vrms for the various loads as contrasted to PI schemes. It indicates that FLC-PI can produces better performances compared to PI schemes in order to achieve Vrms on the DC Chopper output.

3.4 Controller Performance Validation

Validation of a controller performance for use in a large application is a crucial step before the controller can be applied certainty. In this study, simulation results of the controller performances of the DC Chopper are compared to show the controller performance validation. It can be regarded in time-domain validation, concentrating on the time response of different system states to an input command. The outcomes of the time domain reveal the effects of assumptions on nonlinear terms in motion equations.

Figure 14 to Figure 28 present the comparison of the settling time and velocity responses, respectively. They demonstrate that both responses are well operated by the controller. These can be inferred from the system's characteristic and transient reactions, where a close agreement has been reached between simulation work outcomes. However, in the original phase of DC Chopper, a slightly different is observed for the performance response.

4. Conclusions

The performances comparison of control schemes has been developed on a FLC-PI and PI control of DC chopper. This study presents steps of practical design in which the FLC-Pi and PI approach have been used for obtaining gains to control the DC chopper within various payload situation. The control schemes have been implemented and tested on DC chopper. The performance of the control schemes has been assessed in the aspects of input tracking capability, Anchor current, velocity, and total Vrms of DC chopper. An appropriate result in the capability of input tracking has been accomplished with the proposed control schemes. The performances comparison of the control schemes, show that the FLC-PI control strategies presents better than the PI control scheme in reducing the input tracking and performances of DC chopper. Moreover, in terms of the velocity responses, FLC-PI performs in without overshoot for without and with payload, and also faster settling times as contrasted to PI scheme. The FLC-PI controller could be achieving a similar profiles by comprehensive effort, although for every loading condition it is involves arduous tuning effort. This was completed by comparing the simulation for various load. The findings indicate that the suggested controller delivers excellent performance of the actual DC chopper responses. Thus, confidence in the accuracy of the proposed controller for utilization in subsequent investigations for the performance responses for DC chopper systems, has been established.

Acknowledgement

We truly appreciate several supports for this research's funding. The Ministry of Research and Higher Education, Republic of Indonesia readiness to support this study is greatly appreciated by the researchers. High appreciation for the PT Rekindo Global Jasa for collaboration and funding in conducting this study.

References

- [1] Wang, Jiangwen, and Guiming Mei. "Effect of Pantograph's Main Structure on the Contact Quality in High-Speed Railway." *Shock and Vibration* 2021, no. 1 (2021): 4037999. <https://doi.org/10.1155/2021/4037999>
- [2] Fumagalli, Luis Andre Wernecke, Denis Alcides Rezende, and Thiago André Guimarães. "Challenges for public transportation: Consequences and possible alternatives for the Covid-19 pandemic through strategic digital city application." *Journal of Urban Management* 10, no. 2 (2021): 97-109. <https://doi.org/10.1016/j.jum.2021.04.002>
- [3] Zhu, Ming, Sara Ying Zhang, Jason Zheng Jiang, John Macdonald, Simon Neild, Pedro Antunes, João Pombo, Stephen Cullingford, Matthew Askill, and Stephen Fielder. "Enhancing pantograph-catenary dynamic performance using an inertance-integrated damping system." *Vehicle System Dynamics* 60, no. 6 (2022): 1909-1932. <https://doi.org/10.1080/00423114.2021.1884273>
- [4] Wu, Guangning, Guoqiang Gao, Wenfu Wei, Zefeng Yang, Guangning Wu, Guoqiang Gao, Wenfu Wei, and Zefeng Yang. "The current collection approach of high-speed train—pantograph and catenary system." *The Electrical Contact of the Pantograph-Catenary System: Theory and Application* (2019): 1-16. https://doi.org/10.1007/978-981-13-6589-8_1
- [5] Croucamp, Patrick Lindsay, and Arneshtelukdarie. "Lean implementation for rail substation processes." *Journal of Quality in Maintenance Engineering* 24, no. 4 (2018): 468-487. <https://doi.org/10.1108/JQME-08-2017-0056>
- [6] Tian, Zhongbei, Ning Zhao, Stuart Hillmansen, Shuai Su, and Chenglin Wen. "Traction power substation load analysis with various train operating styles and substation fault modes." *Energies* 13, no. 11 (2020): 2788. <https://doi.org/10.3390/en13112788>
- [7] Özdemir, Engin, Atif Ural, Nurettin Abut, Ercüment Karakaş, Ercan Ölçer, and Bülent Karagöz. "Computer-Based Fuzzy Control of a Traction Motor in a Metro Vehicle." *IFAC Proceedings Volumes* 30, no. 12 (1997): 105-110. [https://doi.org/10.1016/S1474-6670\(17\)42772-8](https://doi.org/10.1016/S1474-6670(17)42772-8)
- [8] Navarro, J. L., J. L. Díez, A. Valera, and M. Vallés. "Remote fuzzy control of a DC motor." *IFAC Proceedings Volumes* 41, no. 2 (2008): 13652-13658. <https://doi.org/10.3182/20080706-5-KR-1001.02312>
- [9] Luca, Robert, Michael Whiteley, Toby Neville, Paul R. Shearing, and Dan JL Brett. "Comparative study of energy management systems for a hybrid fuel cell electric vehicle-A novel mutative fuzzy logic controller to prolong fuel cell lifetime." *International Journal of Hydrogen Energy* 47, no. 57 (2022): 24042-24058. <https://doi.org/10.1016/j.ijhydene.2022.05.192>
- [10] Sadiq, A. A., Ganiyu Ayinde Bakare, E. C. Anene, and Hassan Buhari Mamman. "A fuzzy-based speed control of DC motor using combined armature voltage and field current." *IFAC Proceedings Volumes* 46, no. 20 (2013): 387-392. <https://doi.org/10.3182/20130902-3-CN-3020.00146>
- [11] Özdemir, Engin, Atif Ural, Ercüment Karakaş, Ercan Ölçer, and Bülent Karagöz. "Design and application of fuzzy controller for traction motor in metro vehicle." *IFAC Proceedings Volumes* 30, no. 8 (1997): 687-692. [https://doi.org/10.1016/S1474-6670\(17\)43900-0](https://doi.org/10.1016/S1474-6670(17)43900-0)
- [12] Somwanshi, Devendra, Mahesh Bunde, Gaurav Kumar, and Gajal Parashar. "Comparison of fuzzy-PID and PID controller for speed control of DC motor using LabVIEW." *Procedia Computer Science* 152 (2019): 252-260. <https://doi.org/10.1016/j.procs.2019.05.019>
- [13] Zaki, Ahmad M., Mohammad El-Bardini, F. A. S. Soliman, and Mohammed Mabrouk Sharaf. "Embedded two level direct adaptive fuzzy controller for DC motor speed control." *Ain Shams Engineering Journal* 9, no. 1 (2018): 65-75. <https://doi.org/10.1016/j.asej.2015.10.003>
- [14] Wang, Xiuli, Bin Jiang, Ningyun Lu, and Vincent Cocquempot. "Accurate prediction of RUL under uncertainty conditions: Application to the traction system of a high-speed train." *IFAC-PapersOnLine* 51, no. 24 (2018): 401-406. <https://doi.org/10.1016/j.ifacol.2018.09.608>
- [15] Arulmozhiyal, R., and K. Baskaran. "Implementation of a fuzzy PI controller for speed control of induction motors using FPGA." *Journal of Power Electronics* 10, no. 1 (2010): 65-71. <https://doi.org/10.6113/JPE.2010.10.1.065>
- [16] Baz, Rachida, Khalid El Majdoub, Fouad Giri, and Abderrahim Taouni. "Self-tuning fuzzy PID speed controller for quarter electric vehicle driven by In-wheel BLDC motor and Pacejka's tire model." *IFAC-PapersOnLine* 55, no. 12 (2022): 598-603. <https://doi.org/10.1016/j.ifacol.2022.07.377>
- [17] Ashraf, Hossam, Mahmoud M. Elkholy, Sameh O. Abdellatif, and Attia A. El-Fergany. "Synergy of neuro-fuzzy

- controller and tuna swarm algorithm for maximizing the overall efficiency of PEM fuel cells stack including dynamic performance." *Energy Conversion and Management*: X 16 (2022): 100301. <https://doi.org/10.1016/j.ecmx.2022.100301>
- [18] Ammar, Abdelkarim, Billel Talbi, Tarek Ameid, Younes Azzoug, and Abdelaziz Kerrache. "Predictive direct torque control with reduced ripples for induction motor drive based on T-S fuzzy speed controller." *Asian Journal of Control* 21, no. 4 (2019): 2155-2166. <https://doi.org/10.1002/asjc.2148>
- [19] Ben Jabeur, Chiraz, and Hassene Seddik. "Design of a PID optimized neural networks and PD fuzzy logic controllers for a two-wheeled mobile robot." *Asian Journal of Control* 23, no. 1 (2021): 23-41. <https://doi.org/10.1002/asjc.2356>
- [20] Nasiri, Mojtaba, and Ali Arzani. "Robust control scheme for the braking chopper of PMSG-based wind turbines—A comparative assessment." *International Journal of Electrical Power & Energy Systems* 134 (2022): 107322. <https://doi.org/10.1016/j.ijepes.2021.107322>
- [21] Khairudin, M., U. Nursusanto, K. I. Ismara, F. Arifin, D. B. Fahrurrozi, A. Yahya, A. S. Prabuwo, and Z. Mohamed. "Estimated use of electrical load using regression analysis and adaptive neuro fuzzy inference system." *Journal of Engineering Science and Technology* 16, no. 6 (2021): 4452-4467.
- [22] Khairudin, M., R. Refalda, S. Yatmono, H. S. Pramono, A. K. Triatmaja, and A. Shah. "The mobile robot control in obstacle avoidance using fuzzy logic controller." *Indonesian Journal of Science and Technology* 5, no. 3 (2020): 334-351. <https://doi.org/10.17509/ijost.v5i3.24889>
- [23] Agarwal, Vivek. "DC-DC converters (choppers and SMPS)." (2023): 24-35. <https://doi.org/10.1016/B978-0-12-821204-2.00157-4>
- [24] Jain, Akshat, and Dheeraj Joshi. "Realization of class-A chopper using dSPACE." *Procedia computer science* 132 (2018): 563-571. <https://doi.org/10.1016/j.procs.2018.05.010>
- [25] Fujimaki, T., K. Ohniwa, and O. Miyashita. "Simulation of the chopper controlled dc series motor." In *Control in Power Electronics and Electrical Drives*, pp. 609-618. Pergamon, 1978. <https://doi.org/10.1016/B978-0-08-022014-7.50073-4>
- [26] Nasrollahi, R., H. Feshki Farahani, M. Asadi, and M. Farhadi-Kangarlu. "Sliding mode control of a dynamic voltage restorer based on PWM AC chopper in three-phase three-wire systems." *International Journal of Electrical Power & Energy Systems* 134 (2022): 107480. <https://doi.org/10.1016/j.ijepes.2021.107480>
- [27] Best, J., and P. Mutschler. "Control of Armature and Field Current of a Chopper-Fed-DC-Drive by a Single Chip Microcomputer." *IFAC Proceedings Volumes* 16, no. 16 (1983): 515-522. [https://doi.org/10.1016/S1474-6670\(17\)61910-4](https://doi.org/10.1016/S1474-6670(17)61910-4)
- [28] Kumar, N. Senthil, V. Sadasivam, HM Asan Sukriya, and S. Balakrishnan. "Design of low cost universal artificial neuron controller for chopper fed embedded DC drives." *Applied Soft Computing* 8, no. 4 (2008): 1637-1642. <https://doi.org/10.1016/j.asoc.2008.01.001>
- [29] Zadeh, Lotfi A. "Fuzzy sets." *Information and control* 8, no. 3 (1965): 338-353. [https://doi.org/10.1016/S0019-9958\(65\)90241-X](https://doi.org/10.1016/S0019-9958(65)90241-X)
- [30] Nadweh, Safwan, Ola Khaddam, Ghassan Hayek, Bassan Atieh, and Hassan Haes Alhelou. "Time response enhancement for variable speed drive systems by using five-level cascade four quadrant chopper in dc-link." *Heliyon* 6, no. 8 (2020). <https://doi.org/10.1016/j.heliyon.2020.e04739>
- [31] Pidikiti, Tripura, B. Gireesha, Mopidevi Subbarao, and VB Murali Krishna. "Design and control of Takagi-Sugeno-Kang fuzzy based inverter for power quality improvement in grid-tied PV systems." *Measurement: Sensors* 25 (2023): 100638. <https://doi.org/10.1016/j.measen.2022.100638>
- [32] Kumari, K. "Field oriented control of PMSM with model reference adaptive control using Fuzzy-PI controller." *International Journal of Circuit Theory and Applications* 8, no. 1 (2015): 96-108.
- [33] Subbarao, Mopidevi, Kiransai Dasari, SSSR Sarathbabu Duvvuri, K. R. K. V. Prasad, B. K. Narendra, and VB Murali Krishna. "Design, control and performance comparison of PI and ANFIS controllers for BLDC motor driven electric vehicles." *Measurement: Sensors* 31 (2024): 101001. <https://doi.org/10.1016/j.measen.2023.101001>