



Journal of Advanced Research in Applied Sciences and Engineering Technology

Journal homepage:
https://semarakilmu.com.my/journals/index.php/applied_sciences_eng_tech/index
ISSN: 2462-1943



Development of Bionically Inspired Lightweight Design Method for 3D Printed Components

Muhammad Arif Aiman Zulkifly⁴, Norazlianie Sazali^{1,2,*}, Maurice Kettner³, Naqib Salim⁴, Ismayuzri Ishak¹, Saiful Anwar Che Ghani⁵

- ¹ Faculty of Manufacturing and Mechatronic Engineering Technology, University Malaysia Pahang, 26600 Pekan, Pahang, Malaysia
² Centre of Excellence for Advanced Research in Fluid Flow (CARIFF), Universiti Malaysia Pahang Al-Sultan Abdullah, 26600 Pekan, Pahang, Malaysia
³ Institut für Kälte-, Klima- und Umwelttechnik, Karlsruhe University of Applied Sciences, 6133 Karlsruhe, Germany
⁴ Karlsruhe University of Applied Sciences, 76131 Karlsruhe, Germany
⁵ Faculty of Mechanical and Automotive Engineering, Universiti Malaysia Pahang Al-Sultan Abdullah, 26600 Pekan, Pahang, Malaysia

ABSTRACT

Additive manufacturing methods, particularly 3D printing, are widely utilized in research and engineering for crafting lightweight yet durable materials capable of withstanding substantial forces. Leveraging insights from biomechanical structures offers a deeper understanding of reinforcement techniques and optimal design strategies to enhance strength. This paper focuses on the development of a Draisine design, historically significant in Karlsruhe, as part of the BWSplus project "Drais3D-Trinational" workshop. Through a comprehensive analysis of bionic influences on lightweight design and 3D printing parameters, this study aims to create an optimal design framework for the workshop. Utilizing Computer-Aided Design (CAD) software such as SolidWorks and Creo Parametric, along with Finite Element Analysis using ANSYS R2023 Workbench, deformation and stress analysis are conducted. Investigation into 3D printing parameters, including infill patterns, temperature, support systems, and orientation, seeks to identify optimal solutions considering factors like processing time, robustness, and filament wastage. The objective is to explore the biomechanical influence on construction methods, concept design, and parameter construction in preparation for the Drais3D-Trinational workshop in March 2023. The expected outcomes include the presentation of two main designs with varied parameters, alongside analyses such as Finite Element Analysis and optimization of 3D printing parameters, emphasizing the role of bionic structures in defining the optimal Draisine design.

Keywords:

Additive manufacturing; 3D printing;
Biomechanics; Lightweight design

1. Introduction

Additive manufacturing, also referred to as 3D printing, is leading the way in modern production by revolutionizing industries with its unique fabrication method. This advanced technology constructs three-dimensional things by adding layers, providing several approaches to suit different

* Corresponding author.

E-mail address: azlianie@ump.edu.my

<https://doi.org/10.37934/araset.53.1.254270>

user preferences and application requirements. Additive manufacturing includes a range of processes such as powder bed fusion, selective laser sintering, vat polymerization (Stereolithography), binder jetting, directed energy deposition and material jetting utilize the goal of 3D printing to achieve the structures and parameters that the researcher needs [1]. Fused Deposition Modelling (FDM) is a prominent technology in additive manufacturing known for its flexibility and cost-effectiveness. Its uses range from industrial industries to personal hobbies, allowing the development of complex prototypes and functioning pieces. The versatility of FDM has transformed fast prototyping, enabling researchers and manufacturers to quickly develop designs and bring products to market with exceptional efficiency [2].

Success in additive manufacturing depends on several aspects, including process settings and material qualities. Parameters like layer height, thickness, printing speed, temperature control, infill pattern, and percentage are crucial for obtaining the intended outcomes since they directly impact the quality and attributes of the final product [3]. The infill pattern and percentage are crucial factors in influencing the structural integrity and material efficiency. Engineers carefully balance strength and material use by selecting infill patterns such as rectilinear or grid, and percentages, to achieve a precise equilibrium between structural strength and resource efficiency. Comprehending and fine-tuning these factors are crucial for realizing the whole capabilities of additive manufacturing in various applications.

Additive manufacturing is inspired by nature's design principles through biomimicry, in addition to technological aspects. Engineers and designers innovate by studying and imitating nature's effective and eco-friendly solutions, developing technology that work well with the environment [4,5]. Biomimicry promotes a comprehensive engineering approach that combines science with nature's enduring wisdom, from aerodynamic transportation system design to the development of bio-inspired materials [6,7].

This article examines how incorporating biomimicry ideas into additive manufacturing might improve design, functionality, and sustainability. We demonstrate how biomimicry elevates additive manufacturing from a production technique to a channel for innovation by creating a draisine inspired by the natural world. By embracing nature's cleverness, we create a future where technology and the environment coexist peacefully, improving lives and advancing development in unexpected ways.

2. Literature Review

2.1 Investigation of FDM and 3D Printing

Studying 3D printing and its usage in Fused Deposition Modelling (FDM) shows a changing field influenced by technology progress and process improvement. Pham and Gault [2] highlight the crucial importance of fast prototyping with FDM technology, which allows for concurrent engineering and aims to optimize product development efficiency while lowering manufacturing expenses. The focus on efficiency highlights the competitive advantage achieved by using fast prototyping approaches [8]. Rayna *et al.*, [8] emphasize the democratizing impact of 3D printing due to its growing price, making fast prototyping more accessible to people and small enterprises. Enhancing accessibility expands the range of users and promotes innovation in many areas, which in turn drives the advancement of fast prototyping methods. Dey *et al.*, [9] explore the details of process parameters in FDM process optimization to find ways to improve the quality and efficiency of printed products. Researchers want to enhance the performance of FDM technology in fast prototyping applications by optimizing parameters like infill density and raster angle. Durgun *et al.*, [10] highlighted the importance of object orientation in FDM printing, focusing on its effects on surface

roughness and mechanical properties. Their research highlights the intricate relationship between printing settings and the properties of the final product, which helps in attaining the best results in FDM-based manufacturing processes.

FDM is a fundamental aspect of 3D printing techniques, leading to progress in rapid prototyping and production. As competition increases, optimizing process parameters becomes crucial for improving efficiency and quality in FDM-based manufacturing. FDM technology, via ongoing study and improvement, has the potential to transform fast prototyping by providing creative solutions to many technical obstacles.

2.2 3D Printing Filament with Process Parameters

The selection of filament material in Fused Deposition Modelling (FDM) plays a crucial role in determining the quality and characteristics of 3D printed things, highlighting the necessity of making a thoughtful choice. Polylactic Acid (PLA), Acrylonitril-Butadien-Styrol (ABS) and Polyethylene Terephthalate (PETG) are common filaments with distinct properties that are important for various uses in FDM techniques. Researchers, such as Chacón *et al.*, [11] and Abbas *et al.*, [12] have studied the complex relationship between factors including construction orientation, layer thickness, and infill density, explaining how these impact mechanical qualities. The research has shown possible trade-offs, where changes in parameters might improve specific characteristics like as mechanical strength but may negatively affect others like ductility or printing speed.

Tanveer *et al.*, [13] and Yadav *et al.*, [14] have highlighted the importance of infill density and pattern in influencing the structural integrity and performance of printed components, focusing on factors such surface roughness and pattern orientation. Fernandez-vicente *et al.*, [15] and Rodríguez-Panes *et al.*, [16] have provided valuable information on how infill pattern and density affect material strength, emphasizing the need to find a proper balance between these variables for the best results. The study by Palanisamy *et al.*, [17] highlights the importance of parameters such as infill density and raster angle in improving the mechanical properties of PolyJet and FDM printed components. This research contributes to our knowledge of the intricate connection between filament selection, process parameters, and the quality of final prints in FDM-based 3D printing.

2.3 Bicycle and Draisine Design

The bicycle has evolved significantly since it was first created in 1817 by Karl Drais. The original "Draisine" or balancing bike laid the foundation for the contemporary bicycle's development, which has progressed over time with many improvements including the frame, fork, and utilization of new materials. The bicycle's increasing popularity, ease of use, and dependability led to its widespread adoption as a personal mode of transportation. In 1892, it was modified to be used for public transit on suspended rail trips. Bicycles remain significant in both personal and city transportation, as well as in leisure pursuits. Their eco-friendliness, user-friendliness, and adaptability make them a popular choice for individuals of all ages and backgrounds. The future of the bicycle appears promising due to ongoing technological and design improvements, offering significant possibilities for further expansion and progress [18,19]. The design of the first draisine created in 1819 is seen in Figure 1(a), while the design of the current draisine displayed in Figure 1(b) serves as a model for designers and manufacturers to draw inspiration from in order to develop new and improved bicycles.



Fig. 1. (a) Image of Draisine in 1819 [17]. (b) Schematic design of Draisine [16]

2.4 Biomimicry and Bionic Influence

Nature has been a source of inspiration for developing new materials and structures, influencing various industries and uses [1]. Nature's engineering abilities, such as the complex patterns in shells and the strong, flexible properties of spider silk, have fascinated scholars who aim to comprehend and replicate these designs. Biomimicry, the practice of imitating nature, has led to the creation of new materials and design methods that utilize principles found in natural systems. Biomimetic materials, such as those inspired by spider silk or abalone shells, have shown better strength and toughness than traditional materials.

Researchers in the field of 3D printing are increasingly investigating how designs and materials inspired by nature might improve structural qualities and design capabilities. Amit *et al.*, [1] explored the use of 3D printing methods inspired by natural materials and architectures to potentially improve performance beyond typical design approaches. Siddique *et al.*, [20] explored how to imitate porous structures in engineering by using 3D printing to produce lightweight, durable, and energy-absorbing components with specific porosity features. This capacity to regulate pore size, shape, and distribution creates opportunities for developing intricate structures tailored to meet precise engineering needs.

Zhu *et al.*, [21] showcased the potential of combining nature-inspired ideas with modern computational tools in design optimization. Designers may effectively develop lightweight interior support structures for 3D printed components by using hybrid optimization methods and finite element analysis simulations. This helps reduce material wastage and printing time while ensuring structural integrity. Mattheck [22] introduced the notion of "Soft Kill Optimization," which provides techniques to improve designs and increase structural strength by reducing unneeded components and stress points. The methods depicted in Figure 2 of Mattheck's book demonstrate the harmonious combination of design concepts inspired by nature with technical ingenuity, leading to the development of more effective and durable structures for a wide range of applications, such as engine components and bicycles.

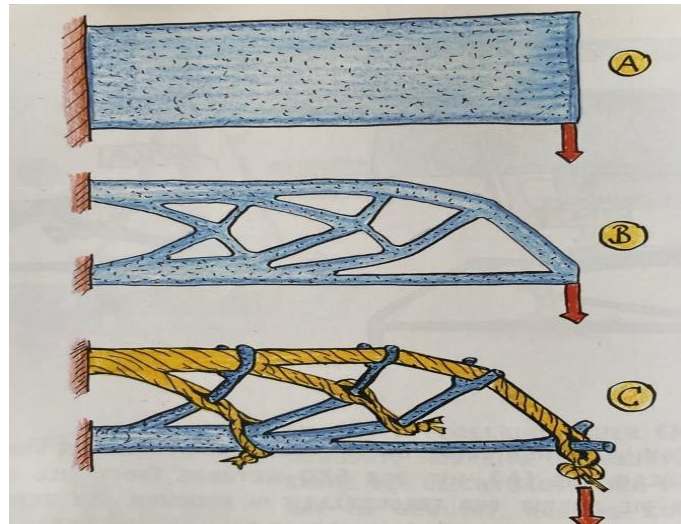

Fig. 2. Example of SKO in Warum Alles Kaputt Geht [26]

2.5 Reinforcement of Design

Reinforcement in design involves increasing a certain feature of a design to increase its performance, longevity, or functionality. This can be accomplished by utilizing a variety of materials and methods, such as reinforcing structures, enhancing the thickness of certain areas, or integrating reinforcements at critical stress locations. Reinforced concrete is a highly utilized building material worldwide. Kloft *et al.*, [23] studied reinforcing techniques for 3D-concrete printing. Additive Manufacturing, also referred to as 3D printing, could significantly transform the methods of reinforcing structures. Designers and engineers may utilize 3D printing to develop elaborate reinforcement patterns tailored to the individual load courses of a building. This enables the development of lighter and more efficient structures that utilize the precise amount of material needed to deliver the requisite strength and stability. Furthermore, 3D printing allows for the development of integrated reinforcing patterns that reduce the necessity for extra assembly reinforcement, hence decreasing the total weight and intricacy of the structure. This not only conserves resource and minimizes prices, but also decreases the time and labour needed for assembly, making it a more efficient option overall. Josten *et al.*, [24] studied arc-welding based additive manufacturing for strengthening applications in automobile engineering. Wire and Arc Additive Manufacturing (WAAM) technology utilizes a welding process to construct metal layers, making it ideal for producing local stiffening elements. This technology enables the creation of intricate shapes that can be precisely positioned to strengthen important body parts.

3. Methodology

3.1 Flow Chart

3D printing is process layering the filament on top of each other until creating a solid part. The steps start with designing the solid structure via Software such SolidWorks or CREO Parametric. Conversion of STL file take place as it is a format or language that can be read by the Slicer Software. Slicer software such Ultimaker Cura enable the designer to reposition the orientation of the parts, adjusting the infill and density of the pattern, control the speed and temperature of the bed and printing time plus to add the support as in tree or normal support. Slicer is then slicing the part to be converted into G-Code as the coding for the printer to move according to the axis. Preview and post

processing is done after the fabrication to remove unnecessary parts and cleaning. Explanation of working flowchart display in Figure 3 below.

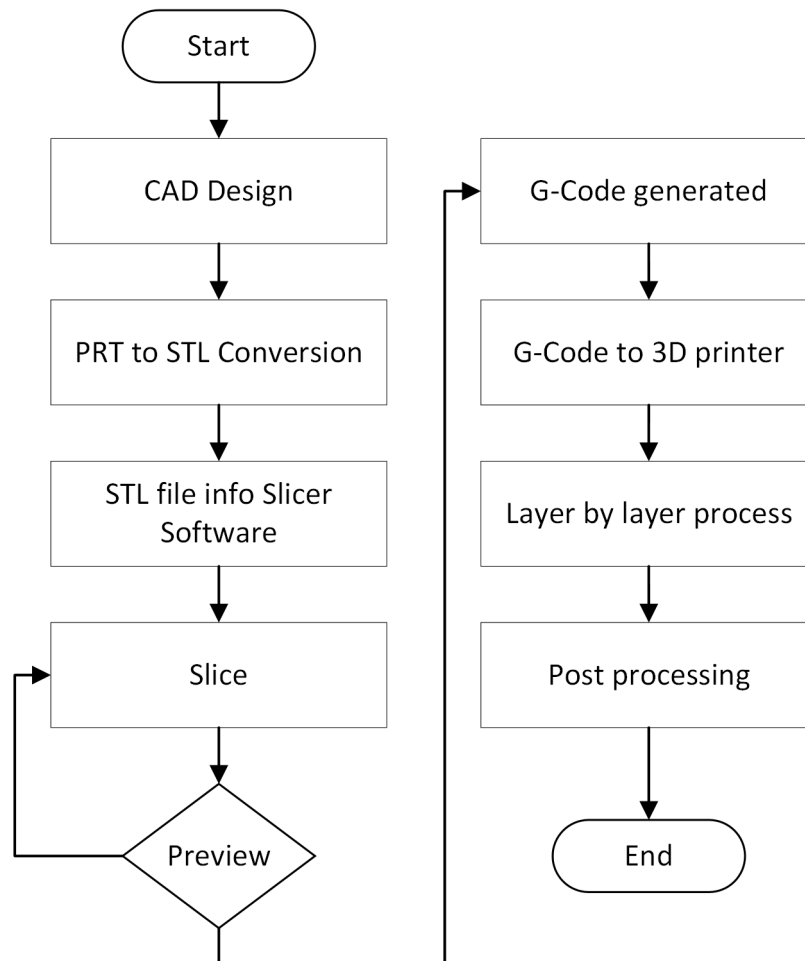

Fig. 3. Flowchart of starting 3D printing

3.2 Design Norms for 3D Printing

Design norms refer to the established and accepted standards, principles, and practices within a particular design field. They can include guidelines for colour use, typography, composition, and other visual elements that are aesthetically pleasing and effective in communicating specific messages. Design norms also include best practices for usability and accessibility, and they can vary across different design disciplines, such as graphic design, product design, interior design, and web design. Design norms are not set in stone and can evolve over time as design trends change and new technologies become available. However, they provide a foundation for designers to work from and can help ensure consistency and quality in the design process. By adhering to design norms, designers can create designs that are both aesthetically appealing and functional and that effectively communicate their intended messages to their intended audiences.

Design norms for 3D printing refer to the best practices, guidelines, and standards that are commonly followed when designing objects for 3D printing. These norms help ensure that the designs are printable, functional, and aesthetically pleasing. Some of the key design norms for 3D printing from DIN EN ISO/ASTM 52900 includes Support material; principle of extrusion; material consideration; design rules; geometry and tolerance; post-processing.

3.2.1 Support materials

Support material in 3D printing refers to a secondary material that is used to support the main part of an object during the printing process. Support material is necessary when printing objects with overhangs, internal structures, or other features that would otherwise collapse or deform during printing. In norm of 3D printing, support structure can be as the same type of materials or different and that depend on the designer to decide. One the first case, it should remove mechanically after the printing process is done. It should be removed with ease using the sharp blade or pliers. On second case, the support structure should be able to remove via chemically or soluble in liquid.

3.2.2 Principle of extrusion

The principle of extrusion refers to a manufacturing process where a material (typically a plastic or metal) is pushed through a shaped die to produce a continuous, one-dimensional object of uniform cross section. For 3D printer, the printer should have the following to allow the extrusion process to happen and Figure 4 is an example of it. The key principle behind the extrusion process is to apply enough pressure to overcome the material's resistance to flow and form it into the desired shape.

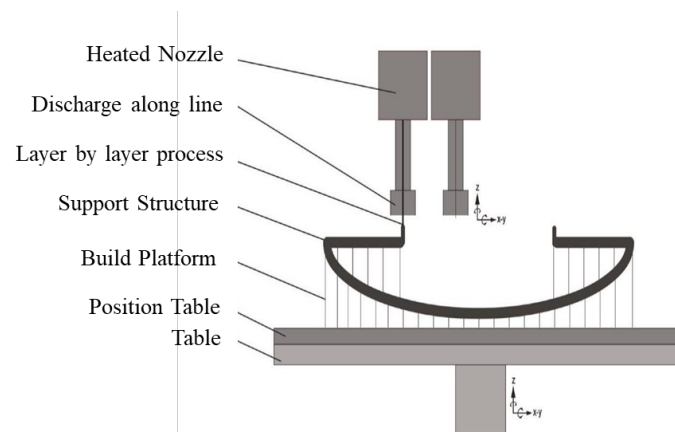

Fig. 4. Part to be in 3D printer [10]

3.2.3 Materials consideration

Material consideration refers to the material insert and melted in the heated nozzle and should be able to discharge from the nozzle in plasticized state. SuiTable processing temperature is dependent on the type of material. Selected material temperature limit can be seen by the provider of the filament and the material should have melted completely during the printing process.

3.2.4 Design rules

Design rules refer to the limitation and aspects to be consider during the printing process to achieve the optimum results and ensure successful printing. For example, in Figure 5, the inner diameter of the front view hole has a diameter of 18 mm.

Numerical values	Not designed for manufacturability	Designed for manufacturability
Vertical: $d \geq 2,0 \text{ mm}$	 <p>minimum diameter of vertical hole, not designed for manufacturability</p>	 <p>minimum diameter of vertical hole, designed for manufacturability</p>
Horizontal: $d \geq 2 \text{ mm } (d \gg 2 t_s)$	 <p>minimum diameter of horizontal hole, not designed for manufacturability</p>	 <p>minimum diameter of horizontal hole, designed for manufacturability</p>

Fig. 5. Example of design rule from DIN EN ISO/ASTM 52900

During the STL conversion, a diameter of 2 mm angle of chord height which is the maximum deviation between the designed part and the STL representation of the part is placed to achieve the perfect design for manufacturing. An example of design norm of DIN EN ISO/ASTM 52900 can be seen in Figure 6.

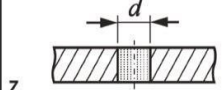
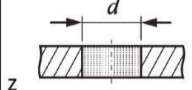
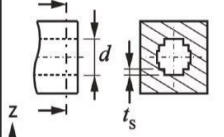
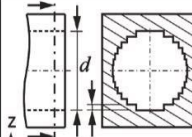
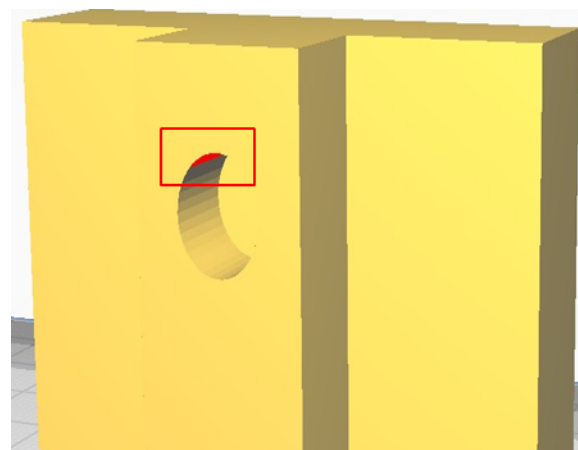

Fig. 6. Example of inner dimension has 2 mm chord height in red frame

3.2.5 Geometry and tolerance

The geometry of the design refers to its shape, size, and arrangement of features. In 3D printing, it is important to consider the design's functionality and strength, as well as its ability to be printed successfully. Tolerance refers to the amount of allowable deviation from a nominal dimension. In 3D printing, tolerance is a crucial aspect that determines the accuracy and precision of the final print.

3.2.6 Post processing

Post-processing is an important step in the 3D printing process that can improve the final quality, appearance, and durability of your printed object. Post processing is advisable for the support structure to be removed mechanically via polishing or grinding as and provide inlet and outlet for removing internal structure.

3.3 Methodology for Bionic Influence

Draisine is the focus of the object to be printed and analysed at the end of the research paper. By involving the influence of bionic structure, the main goal of the thesis paper which is creating a lightweight structure with a high tolerance of stress can be achieved. The influence of bionic mainly focuses on designing the frame of the draisine. Before designing the draisine, limitation or the forces applied onto the draisine need to be specified to give more insight towards the expected outcome of the printed parts.

For concept design of Draisine, three main designs are created to perform the analysis. The criteria for the analysis include Different frame, Type of material, Weight, and Process parameters of the 3D printer Different frame refers to different influence of the design. A design following nature inspired and an aesthetic design which has a curvature area in the Finite Element Analysis. Example of aesthetic design can be seen in Figure 2 where at the seat contain hole and the frame is slightly bending in the blue frame. To perform a finite element analysis on the Draisine, the forces applied on the Draisine need to be considered. Schematic of the forces applied during the position of leaning forward in static can be seen in Figure 7(a) and the boundary condition on the design in Figure 7(b).

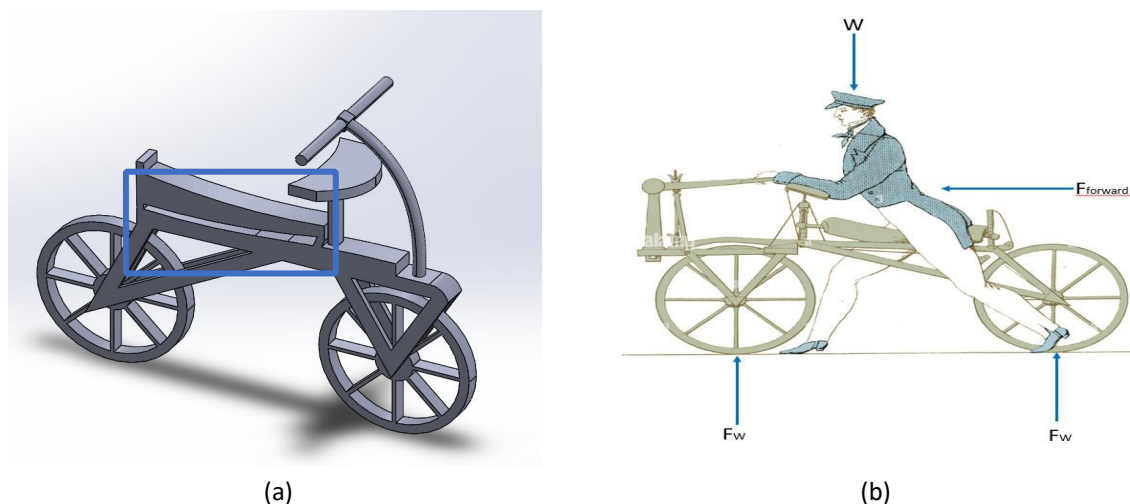

(a) (b)
Fig. 7. (a) Aesthetic design of Draisine (b) Schematic view of forces

The dimension of the Draisine and forces applied are according to the actual norm of bicycle which is the ISO/DIS 4210 – 6:2021 (E). The force of 784.8 N refers to the actual human weight of 80 kg. Material PLA is chosen because it contains greater tensile strength and the tendency to break during the analysis is lower than ABS.

3.4 Selection of Process Parameters during Printing

The selection of process parameters during printing depends on the type of printing technology being used, the material being printed, and the desired outcome of the print. For this methodology, selection of process parameters includes Infill Density and Infill pattern, Speed of Printing, Temperature, Support structure.

Infill densities of 20% and 40% are to be investigated in this thesis as both percentages is commonly used by researcher such as Chacon *et al.*, [11] and suiTable to show the value of density inside the printed part. Speed of the printing can determine the time consume for the printed parts to finish. Speed of 50 and 100 is to be studied in this paper. Temperature of the printed bed and nozzle is constant which is 65° C and 210° C respectively. Support structures help when a part contains

overhang. If the parts are printed separately and later combined with hot glue, support structures will be necessary on the touching build plate.

The printed part of the design is scaled down to 0.1 of the actual design. The outcome of this analysis can be determined by: time consumed, weight of the filaments used, and strength testing by hanging weight underneath the printed parts.

4. Results and Discussion

4.1 Material Selection

Finite element analysis or FEA is a numerical method used to solve and analyse engineering problems by dividing a complex structure or system into smaller, simpler parts called finite element. To begin the structural analysis of the design, the material PLA has been chosen in the FEA-software to test out as the outcome of prototype design will be printed with PLA filament. The mechanical properties of the PLA used in this analysis is display in Table 1 and Figure 8.

Table 1
 Mechanical Properties of PLA [25]

Mechanical Properties	Value	Unit
Density	4.107	g cm ⁻³
Young's modulus	0.3	GPa
Poisson's ratio	3.4225e+09	Pa
Shear modulus	1.5796e+09	Pa
Tensile Yield Strength	60	MPa
Compressive Yield Strength	66.78	MPa
Tensile Ultimate Strength	49.5	MPa
Compressive Ultimate Strength	25	MPa

	A	B	C	D	E
1	Property	Value	Unit		
2	Material Field Variables	Table			
3	Density	1.24	g cm ⁻³		
4	Isotropic Elasticity				
5	Derive from	Young's Mo...			
6	Young's Modulus	4.107	GPa		
7	Poisson's Ratio	0.3			
8	Bulk Modulus	3.4225E+09	Pa		
9	Shear Modulus	1.5796E+09	Pa		
10	Tensile Yield Strength	60	MPa		
11	Compressive Yield Strength	66.78	MPa		
12	Tensile Ultimate Strength	49.5	MPa		
13	Compressive Ultimate Strength	25	MPa		

Fig. 8. Mechanical properties PLA in Ansys workbench

4.2 Analysis on Finite Element Method

Two completed designs were studied in this paper. The differences can be seen in the frame design that has a larger area of structure with less area of curvature and another with curvature hole between the seat and frame holder. The design for both parameters is shown in Figure 9.

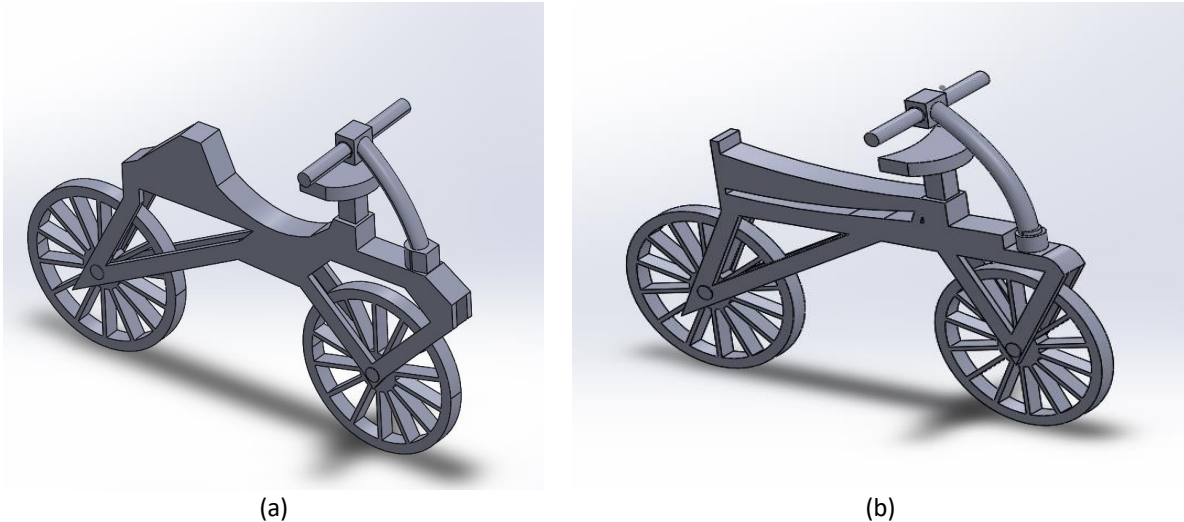

(a) (b)
Fig. 9. (a) Draisine first design (b) Draisine second design

For both design, designs were created in SolidWorks as a SLDPRT. -file. SLDPRT is a file extension used by the software program SolidWorks, which is a 3D CAD (Computer-Aided Design) software tool developed by Dassault Systemes. SLDPRT files are created when a new part is designed in SolidWorks and they contain the part geometry, including sketches, features, and dimensions which is then transferred into Ansys Workbench for FEA simulation. New plane was added in the DesignModeler in SolidWorks to make a differentiation on the original plane and added plane. This will help to slice two different planes for one body, thus can obtain greater FEA results. With reference to YZ plane and offset X axis -0.478m , the slice method can be done to separate some parts of the area of the wheel with the touching ground. In Figure 10(a) is clearly seen the small green area indicate the touching area of tires during position on the ground.

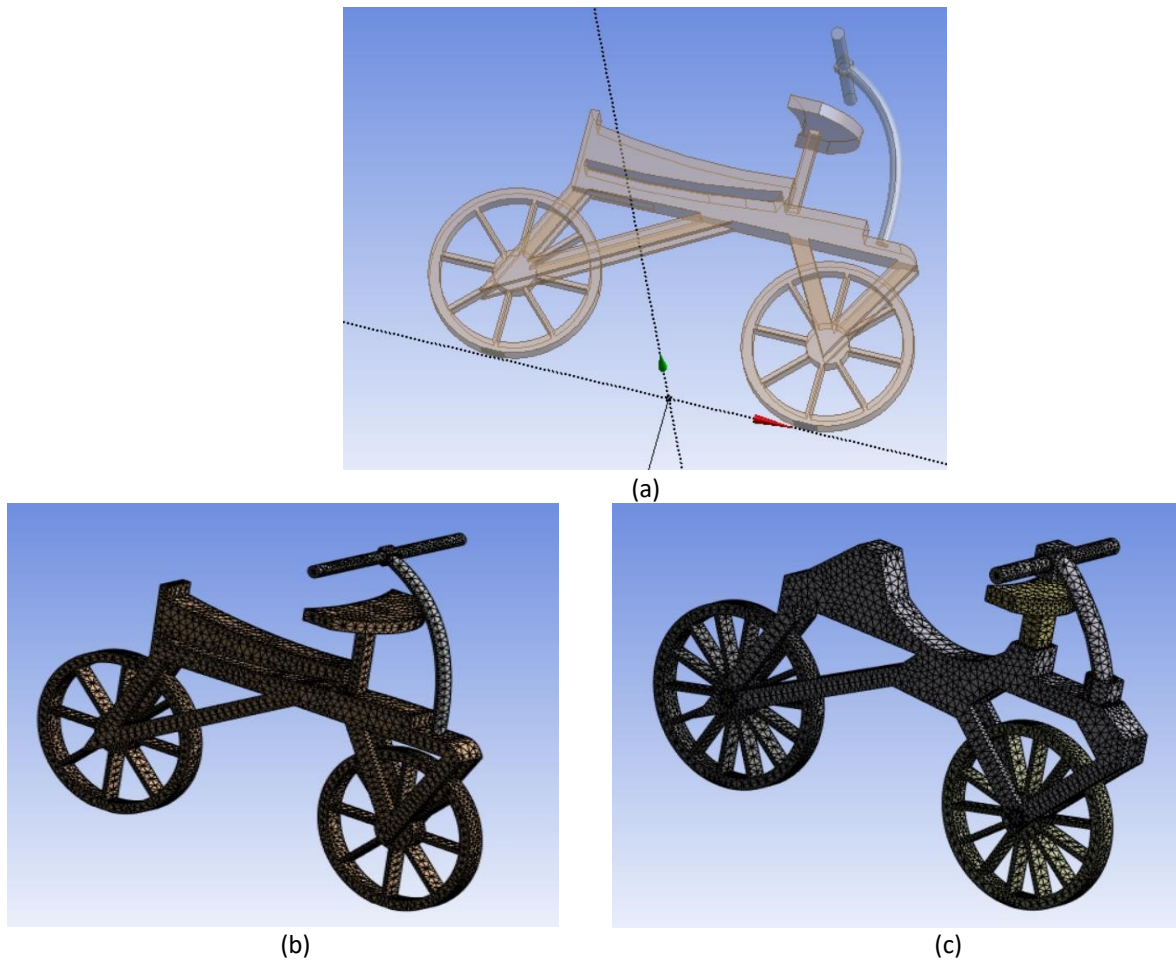

Fig. 10. (a) Partition slice of Draisine design, (b) Meshing property of first design (c) Meshing property of second design

The meshing for both designs contains element size of 10 mm with the first design having a total of 104859 nodes and elements in Figure 10(b) while second design has a total of 81140 nodes and elements in Figure 10(c). After setting the boundary condition as in Figure 7(b) for both designs, a result for total deformation, stress, strain, and safety factor obtain and compare to set the best design. For better view of comparison for the results, Summarization of the experimental obtain results can be seen in Table 2.

Table 2
 Comparison results for the FEA

Result	Design 1	Design 2
Total Deformation (mm)	1.2233	10.579
Equivalent Stress (MPa)	12.56	35.724
Equivalent Elastic Strain (mm)	0.0031074	0.0087477
Safety factor	4.777	1.6795

The comparison of Design 1 and Design 2 for the Draisine design, with Design 1 incorporating bionic structures, yields valuable insights into the structural performance and resilience of each design. Firstly, the incorporation of bionic-inspired elements in Design 1 has resulted in a frame that closely follows the typical design principles of bicycles, leading to reduced regions of curvature. This element is essential because it reduces the risk of excessive bending moments and concentrated tensile stress, which can have a considerable impact on the structural strength and durability of the

draisine. In addition, Design 1's lack of holes or exposed regions reduces the likelihood of stress concentration spots, such as notches, which might cause cracks to form and spread when subjected to oscillating loads.

Finite Element Analysis (FEA) results show that Design 1 has less total deformation than Design 2, especially for load-bearing structures. The reduced total deformation indicates increased stability and safety under heavy loads, further supporting the appropriateness of Design 1 for applications prioritizing structural integrity. Design 1 shows lower stress levels compared to Design 2 based on the equivalent stress analysis. The observation highlights the superior robustness and resilience of Design 1, indicating its ability to withstand external forces and loads without failure or plastic deformation.

Design 1 demonstrates a higher factor of safety in the analysis compared to Design 2, indicating its structural superiority. A higher factor of safety reflects a design's capacity to endure unforeseen loads or stresses, improving the safety and reliability of the structure or system. To summarize, the integration of bionic-inspired structures in Design 1 has led to a stronger and more stable Draisine design in comparison to Design 2. Emphasizing adherence to bicycle design norms, minimizing stress concentration points, and achieving superior performance in FEA analyses highlight the effectiveness of bionic influence in optimizing structural performance and reliability. This discussion highlights the significance of incorporating bionic principles into engineering design, especially in situations where strength, stability, and safety are crucial.

4.3 Analysis on 3D Print Process Parameter

The analysis of 3D printing considers filament weight, design robustness, infill percentage, temperature, and printing speed. This thesis aims to optimize design parameters for strength, filament efficiency, reduced printing time, and lower weight. Figure 11 illustrates how varying infill percentages affect printing speed, highlighting the importance of balancing these factors for efficient and effective 3D printing.

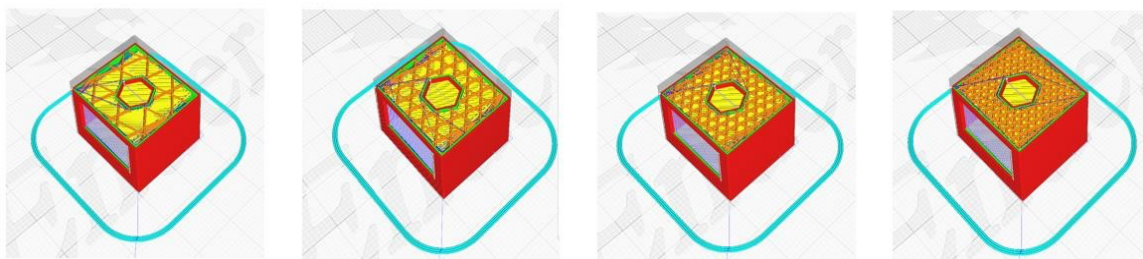
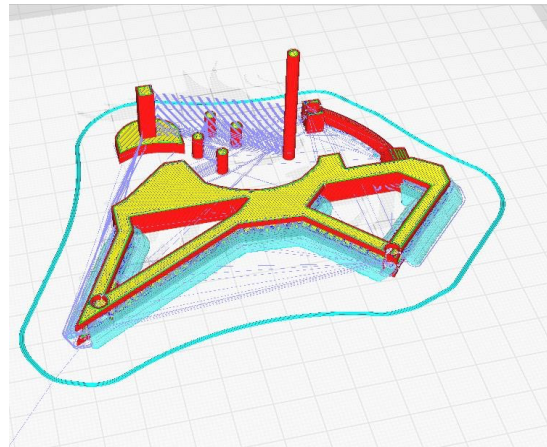
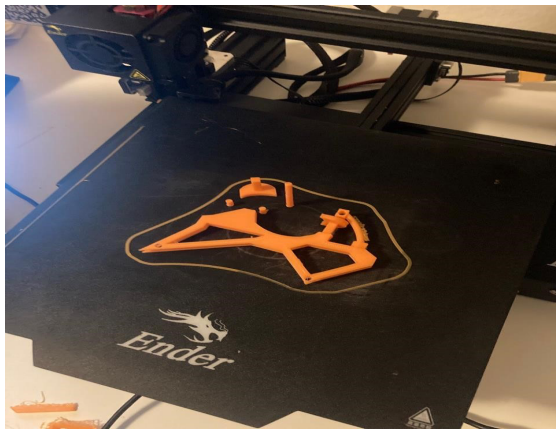

Fig. 11. Different infill comparison

To compare design parameters, all designs were disassembled into multiple parts and printed individually on the build plate. After printing, the parts were assembled into a single piece. Incorporating a tolerance of ± 0.5 mm for connecting parts minimized the need for additional cutting and post-processing efforts. Figure 12(a) illustrates the finished product of the second design on the build plate, while the experimental positioning of the designs can be observed in Figure 12(b). Complete assemblies of both designs are depicted in Figure 12(c) as examples.



(a)



(b)



(c)

Fig. 12. (a) Orientation of 1st design in Ultimaker Cura (b) Experimentally obtain position of design on build plate (c) Example of both designs assembled

To examine various parameters, Figures 13 depict different previews in Ultimaker Cura, with accompanying tables for clarity. Each colour in the figures signifies a specific function: yellow denotes the extruder path, dark blue indicates the traveling line based on the G-Code file, light blue serves as a guide for traveling, red represents the outer shell of the printed part, orange depicts the infill pattern, yellow represents the top and bottom parts of the printed piece, and green illustrates the inner wall. This visual representation aids in understanding how different settings and configurations impact the printing process and the final product's quality and characteristics.

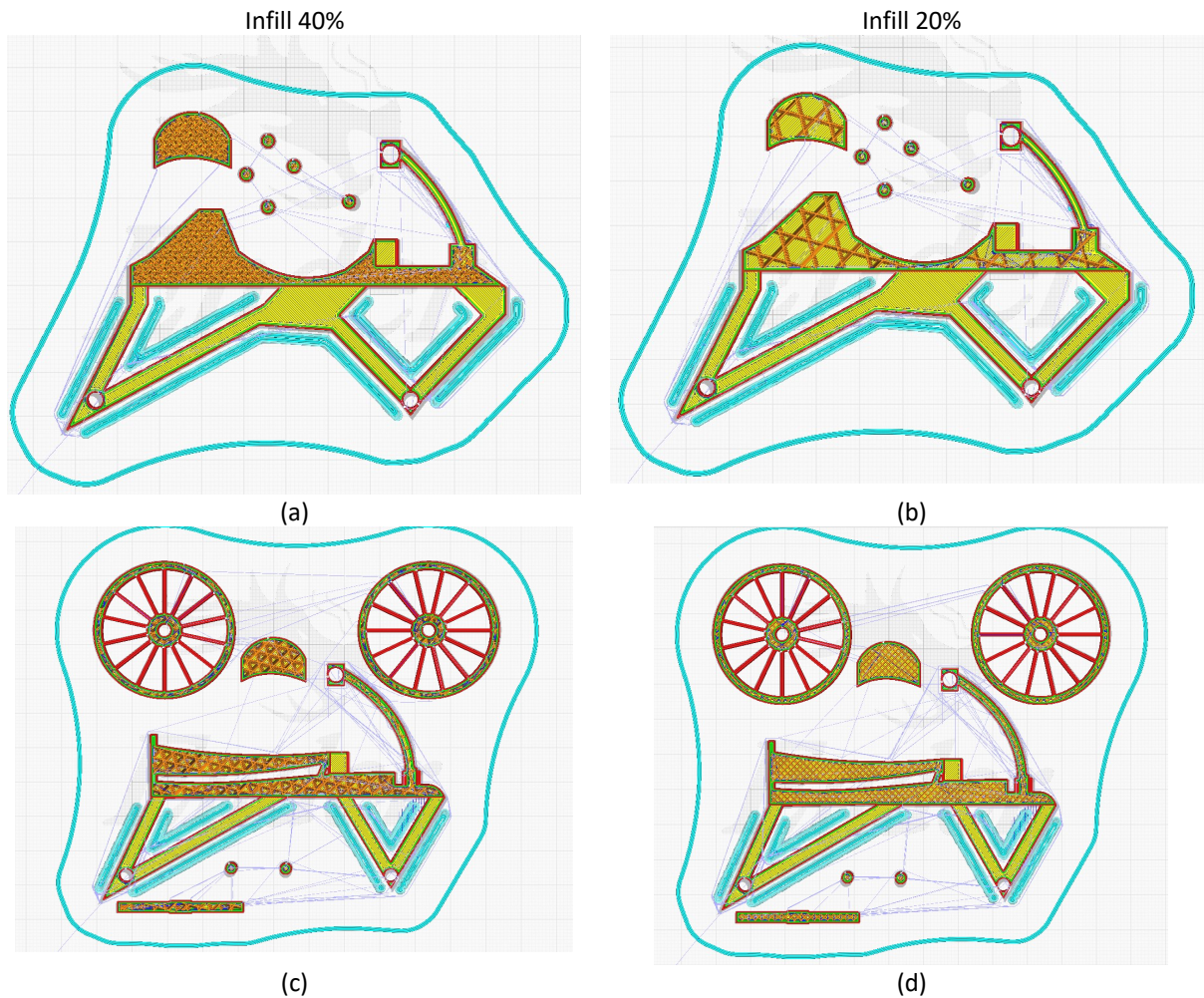

Fig. 13. 1st draisine design with infill 40% (b) 1st draisine design with infill 20%, (c) Draisine 2nd design with infill 40% (d) Draisine 2nd design with infill 20%

Table 3

Comparison of process parameters for both designs

Design	Infill Pattern	Infill Density (%)	Weight filament (g)	Time (min)	Printing speed (mm/s)
1	Cubic	20	8	83 mins	50
1	Gyroid	40	9	95 mins	100
2	Cubic	40	9	94 mins	100
2	Line	30	9	90 mins	50

For optimal design, a higher infill density indicates greater strength, allowing for the support of heavier loads without breaking or elongating. Increasing the infill density improves the structural integrity, similar to hanging a weight underneath the design. A study demonstrates that increasing infill density enhances specimen properties by improving inter-layer adhesion. Yet, achieving peak performance also depends on variables like the pattern type and temperature configurations of the build plate and nozzle.

The gyroid pattern is favoured for its lattice-like structure, providing greater robustness than line and cubic patterns. Although printing times may be extended, the gyroid pattern demonstrates exceptional shape retention and resilience under weight-bearing conditions. Printing at a speed of 100 mm/s enables fast layer building, leading to quicker prototyping and product creation. It is

important to consider that increased printing speeds can affect the quality of prints and necessitate precise calibration.

Both designs show high filament consumption, using up to 9 grams, especially noticeable in designs with tree supports connected to the build plate. Optimizing support structures is crucial to minimize material wastage and improve efficiency in 3D printing processes.

5. Conclusions

The objective of this thesis is to develop an example of bionic influence design that can be fabricated with an FDM machine. A draisine or any design with bionic structure is more robust than aesthetic design. Aesthetic design means that the design has areas which are not in linear position. Linear position designs can lead to reduced tensile force that are created by the bending moment in any bending structure.

Bionic inspiration is a good solution for engineering solution to create new ideas and crafting multiple knowledge as we learn by observing and adapt it in our lives. This thesis also includes on how the bionic inspiration such as structure of a tree can be adapted in Additive Manufacturing or 3D printing. 3D printing is vast and can be used for prototyping modelling. From designing parts with actual dimension, 3D printing enables designers or manufacturers to print out the scale design of the actual dimension as a prototype. It is very cost effective to see the shape of the original design in prototype version as it requires a printer and good care of filament that doesn't cost very high.

This paper will be a guidance for the future students that will be doing Drais3D-Trinational for their exchange semester in Malaysia, Ethiopia and Germany. With the references from this paper can give an insight for the future students to fabricate their own designs, learn more about bionic inspired and 3D printing and finally make their learning more efficient in the future.

Acknowledgement

This research was funded by a grant from Universiti Malaysia Pahang for funding under grant RDU232707 and UIC231511.

References

- [1] Bandyopadhyay, Amit, Kellen D. Traxel, and Susmita Bose. "Nature-inspired materials and structures using 3D Printing." *Materials Science and Engineering: R: Reports* 145 (2021): 100609. <https://doi.org/10.1016/j.mser.2021.100609>
- [2] Pham, Duc Truong, and Rosemary S. Gault. "A comparison of rapid prototyping technologies." *International Journal of machine tools and manufacture* 38, no. 10-11 (1998): 1257-1287. [https://doi.org/10.1016/S0890-6955\(97\)00137-5](https://doi.org/10.1016/S0890-6955(97)00137-5)
- [3] Tanveer, Md Qamar, Gautam Mishra, Siddharth Mishra, and Rohan Sharma. "Effect of infill pattern and infill density on mechanical behaviour of FDM 3D printed Parts-a current review." *Materials Today: Proceedings* 62 (2022): 100-108. <https://doi.org/10.1016/j.matpr.2022.02.310>
- [4] Zainal, Salbiah, Rasimah Che Mohd Yusoff, Hafiza Abas, Suraya Yaacob, and Norziha Megat Zainuddin. "Review of design thinking approach in learning IoT programming." *International Journal of Advanced Research in Future Ready Learning and Education* 24, no. 1 (2021): 28-38.
- [5] Ishak, Norshahidatul Hasana, Siti Nurul Mahfuzah Mohamad, Syamimi Shamsuddin, Intan Fatimah Ahmad, Mohamad Lutfi Dolhalit, Hazmilah Hasan, Norazah Mohd Nordin, and Nor Hafizah Adnan. "Autism Robot (AuRo) Framework to Facilitate Learning for Children with Autism Spectrum Disorder (ASD)." *Journal of Advanced Research in Applied Mechanics* 108, no. 1 (2023): 111-123. <https://doi.org/10.1109/ISCAIE57739.2023.10165357>
- [6] Wegst, Ulrike GK, Hao Bai, Eduardo Saiz, Antoni P. Tomsia, and Robert O. Ritchie. "Bioinspired structural materials." *Nature materials* 14, no. 1 (2015): 23-36. <https://doi.org/10.1038/nmat4089>
- [7] Katiyar, Nirmal Kumar, Gaurav Goel, Sara Hawi, and Saurav Goel. "Nature-inspired materials: Emerging trends and prospects." *NPG Asia Materials* 13, no. 1 (2021): 56. <https://doi.org/10.1038/s41427-021-00322-y>

- [8] Rayna, Thierry, and Ludmila Striukova. "From rapid prototyping to home fabrication: How 3D printing is changing business model innovation." *Technological forecasting and social change* 102 (2016): 214-224. <https://doi.org/10.1016/j.techfore.2015.07.023>
- [9] Dey, Arup, and Nita Yodo. "A systematic survey of FDM process parameter optimization and their influence on part characteristics." *Journal of Manufacturing and Materials Processing* 3, no. 3 (2019): 64. <https://doi.org/10.3390/jmmp3030064>
- [10] Durgun, Ismail, and Rukiye Ertan. "Experimental investigation of FDM process for improvement of mechanical properties and production cost." *Rapid Prototyping Journal* 20, no. 3 (2014): 228-235. <https://doi.org/10.1108/RPJ-10-2012-0091>
- [11] Chacón, Jesus Miguel, Miguel Angel Caminero, Eustaquio García-Plaza, and Pedro J. Núñez. "Additive manufacturing of PLA structures using fused deposition modelling: Effect of process parameters on mechanical properties and their optimal selection." *Materials & Design* 124 (2017): 143-157. <https://doi.org/10.1016/j.matdes.2017.03.065>
- [12] Abbas, T., Farhad Mohammad Othman, and Hind Basil Ali. "Effect of infill Parameter on compression property in FDM Process." *dimensions* 12, no. 7 (2017): 25-4.
- [13] Tanveer, Md Qamar, Abid Haleem, and Mohd Suhaib. "Effect of variable infill density on mechanical behaviour of 3-D printed PLA specimen: an experimental investigation." *SN Applied Sciences* 1 (2019): 1-12. <https://doi.org/10.1007/s42452-019-1744-1>
- [14] Yadav, Pushpendra, Ankit Sahai, and Rahul Swarup Sharma. "Strength and surface characteristics of FDM-based 3D printed PLA parts for multiple infill design patterns." *Journal of The Institution of Engineers (India): Series C* 102 (2021): 197-207. <https://doi.org/10.1007/s40032-020-00625-z>
- [15] Fernandez-Vicente, Miguel, Wilson Calle, Santiago Ferrandiz, and Andres Conejero. "Effect of infill parameters on tensile mechanical behavior in desktop 3D printing." *3D printing and additive manufacturing* 3, no. 3 (2016): 183-192. <https://doi.org/10.1089/3dp.2015.0036>
- [16] Rodríguez-Panes, Adrián, Juan Claver, and Ana María Camacho. "The influence of manufacturing parameters on the mechanical behaviour of PLA and ABS pieces manufactured by FDM: A comparative analysis." *Materials* 11, no. 8 (2018): 1333. <https://doi.org/10.3390/ma11081333>
- [17] Palanisamy, Chandramohan, Raghu Raman, and Pradeesh Kumar Dhanraj. "Additive manufacturing: a review on mechanical properties of polyjet and FDM printed parts." *Polymer Bulletin* 79, no. 9 (2022): 7065-7116. <https://doi.org/10.1007/s00289-021-03899-0>
- [18] Waldbaur, Ansgar, Holger Rapp, Kerstin Länge, and Bastian E. Rapp. "Let there be chip—towards rapid prototyping of microfluidic devices: one-step manufacturing processes." *Analytical Methods* 3, no. 12 (2011): 2681-2716. <https://doi.org/10.1039/c1ay05253e>
- [19] Gross, Bethany C., Jayda L. Erkal, Sarah Y. Lockwood, Chengpeng Chen, and Dana M. Spence. "Evaluation of 3D printing and its potential impact on biotechnology and the chemical sciences." (2014): 3240-3253. <https://doi.org/10.1021/ac403397r>
- [20] Siddique, Shakib Hyder, Paul J. Hazell, Hongxu Wang, Juan P. Escobedo, and Ali AH Ameri. "Lessons from nature: 3D printed bio-inspired porous structures for impact energy absorption—A review." *Additive Manufacturing* 58 (2022): 103051. <https://doi.org/10.1016/j.addma.2022.103051>
- [21] Zhu, Lin, Ruiliang Feng, Xianda Li, Juntong Xi, and Xiangzhi Wei. "Design of lightweight tree-shaped internal support structures for 3D printed shell models." *Rapid Prototyping Journal* 25, no. 9 (2019): 1552-1564. <https://doi.org/10.1108/RPJ-04-2019-0108>
- [22] Matteck, C. "Warum alles kaputt geht. Form und Versagen in Natur und Technik. Forschungszentrum Karlsruhe, S 208." (2003).
- [23] Kloft, Harald, Martin Empelmann, Norman Hack, Eric Herrmann, and Dirk Lowke. "Reinforcement strategies for 3D-concrete-printing." *Civil Engineering Design* 2, no. 4 (2020): 131-139. <https://doi.org/10.1002/cend.202000022>
- [24] Josten, A., and MJWitW Höfemann. "Arc-welding based additive manufacturing for body reinforcement in automotive engineering." *Welding in the World* 64, no. 8 (2020): 1449-1458. <https://doi.org/10.1007/s40194-020-00959-3>
- [25] Kholil, A., E. Asyaefudin, N. Pinto, and S. Syaripuddin. "Compression strength characteristics of ABS and PLA materials affected by layer thickness on FDM." In *Journal of Physics: Conference Series*, vol. 2377, no. 1, p. 012008. IOP Publishing, 2022. <https://doi.org/10.1088/1742-6596/2377/1/012008>