



## Journal of Advanced Research in Fluid Mechanics and Thermal Sciences

Journal homepage:  
[https://semarakilmu.com.my/journals/index.php/fluid\\_mechanics\\_thermal\\_sciences/index](https://semarakilmu.com.my/journals/index.php/fluid_mechanics_thermal_sciences/index)  
ISSN: 2289-7879



# Application of Flywheel Energy Storage on Generator-Set

Fakhrizal Akbar Ilmiawan<sup>1,\*</sup>, Sheikh Ahmad Zaki<sup>1</sup>

<sup>1</sup> Department of Mechanical Precision Engineering, Malaysia-Japan International Institute of Technology, Universiti Teknologi Malaysia

### ARTICLE INFO

### ABSTRACT

#### Article history:

Received 5 January 2023  
Received in revised form 6 April 2023  
Accepted 13 April 2023  
Available online 30 April 2023

#### Keywords:

Flywheel Energy Storage; energy; rotational kinetic energy; generator-set; electromotor; generator

The generator-sets have been widely used as a secondary or an emergency standby power by the society. Despite their several benefits such as their simplicity and reliability, they meet a stability and efficiency decrease when they produce the power. Referring to the above reason, this experimental study is aimed to investigate the potential benefits of the addition of the flywheel energy storage device to generator-set systems, in the term of output power stability concept. In this research, the generator-set system is simulated by using an electromotor as a prime mover coupled with a flywheel, to generate electricity from a generator or alternator. The flywheel basically acts as an energy storage device that stores energy in the form of the rotational kinetic energy. Therefore, the generator-set simulations are performed in loaded and unload conditions, with three different variations; (1) no flywheel, (2) connected to an 8.5 kg flywheel and (3) connected to a 16 kg flywheel. The result shows that the system which is connected to a 16 kg flywheel has a higher magnitude of the rotational kinetic energy than two other test variations, due to its bigger mass of flywheel. The variation (3) also has more stable and economical output when it is fully loaded by two sets of drilling machine in which indicated by the smallest drop rate of the alternator rotational speed and the less electromotor current usage among two others.

## 1. Introduction

The global demand for secondary or emergency power supply continues to increase due to the population growth and the development of the industry [1]. There are many kinds of secondary power sources that have commonly been known such as the generator sets (gen-set) and the uninterruptible power supplies (UPS), or the latest developed ones like solar powers, fuel cells and the combination of certain models of power generations called the hybrid systems [2-4]. Due to the benefits such as their simplicity and reliability, generator set systems have been widely used by the society and industrial world. However, they meet an output stability and efficiency decrease when they are operated in a peak condition [5].

The generator sets basically consist of a diesel or electrical motor (the driver) that are connected to generators or alternators (the driven) by using the pulleys and the belts to generate electricity. In

\* Corresponding author.

E-mail address: [fkhrzlakbr@gmail.com](mailto:fkhrzlakbr@gmail.com)

<https://doi.org/10.37934/arfmts.105.2.7887>

the term of the quality and the efficiency of gen-set systems, the load consideration factor, along with the fuel, the operating conditions and the capacity design, is one of the factors that affects them. The systems are ideally operated in the standard temperature and pressure (STP) condition around 80% of their total capacity, although it is designed to bear the 100% load. However, the gen-sets are sometimes maximumly operated to deliver the 100% of their capacity under the emergency usage resulting in the decrease of the rotational speed that causes an output drop [6,7].

Numerous researches have been conducted in order to study the possibility to enhance the quality and the efficiency of the generator from various aspects, such as the fuel combinations [8] and the frequency controls [9]. In a brief, this experimental study is designed to investigate the potential benefits from the mechanical point of view by adding the flywheel energy storage (FES) in the gen-set systems. The previous study shows that the FES has been applied in the small-scale microhydro turbine power plant and the result is that the FES can smoothen the output of the microhydro power plant when there is a sudden load change, because the flywheel acts as the reservoir that stores the energy in the form of the rotational kinetic energy and releases it when it is needed [10]. Due to the above reasons, this paper is aimed to study the advantage possibility of the application of FES in the term of the output stability concept.

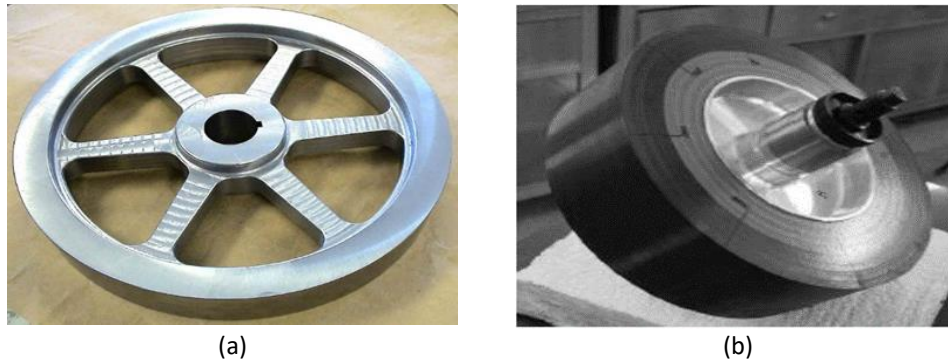
## **2. Theoretical Review**

The theoretical reviews on this research are emphasized on the theories that are used to analyze the application of the flywheel on the gen-set system. They are the flywheel energy storages and the rotational kinetic energy.

### *2.1 Flywheel Energy Storage (FES)*

The energy storage has recently become a discussion topic in the context of the energy shifting and the transition from the fossil fuels to the renewable ones [11]. Among the existing energy storage technologies, the electrochemical batteries are the leading ones. However, they also have a number of environmental disadvantages such as the hazardous chemical substances and the “grey” energy. Therefore, an environmentally friendlier technology will be needed here [12,13].

Basically, the flywheel energy storages (FES) are a rotating cylinder or wheel with a specific mass and diameter that stores energy in the form of the rotational kinetic energy. They are mostly manufactured from the iron or steel (as shown in Figure 1.a) for the commercial usage and the composite or the fiber (as shown in Figure 1.b) for the special application or the research. The FES acts as the energy reservoir during the period when the energy supply is more than the required and release it when the energy required is more than the energy supply [14-17]. The FES models have also been developed for several years and they have been widely applied in various ways, whether for the commercial use such as the combustion engines, the reciprocating compressors and the pumps, or the specialized purpose like the uninterruptible power supply (UPS) systems, the automobile breaking systems, the hybrid cars and the grid stabilizations [18-21].



**Fig. 1.** (a) Steel flywheel [16], (b) Composite flywheel [22]

## 2.2 Rotational Kinetic Energy

The rotational kinetic energy theorem begins with a basic concept of the kinetic energy itself. The kinetic energy is the representation of the energy associated with the motion of the particle or object. Hence, the rotational kinetic energy is defined as the energy associated with the object that rotates in a circular path [23].

$$K = \frac{1}{2} m v^2 \quad (1)$$

The basic kinetic energy equation (K) expressed in the Eq. (1), where  $m$  (kg) and  $v$  (m/sec) are the mass and the tangential speed of the object respectively. Consider the object as the flywheel (Figure 1) and assume it rotates about a fixed axis with an angular speed  $\omega$  (rad/sec), then the tangential speed can be written as

$$v = \omega r \quad (2)$$

where  $r$  represents the radius of the flywheel (m). From the Eq. (1) and Eq. (2), the rotational kinetic energy ( $K_R$ ) can be expressed as

$$K_R = \frac{1}{2} m v^2 = \frac{1}{2} m r^2 \omega^2 \quad (3)$$

From the above equation, the bigger the magnitude of the rotational kinetic energy, the more the object tends to rotate about its axis and vice versa [16,23]. Therefore, the flywheel application on this research is expected to smoothen and to stabilize the output of the generator set when it comes to be fully loaded because of the rotational kinetic energy from the flywheel.

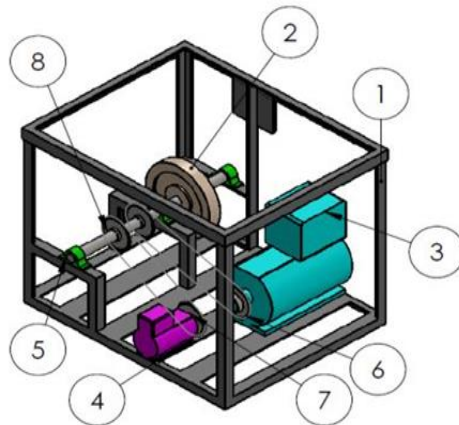
## 3. Methodology

This methodology will explain the system design and the specification, and the data compilation.

### 3.1 System Design

This experimental study is conducted by adopting the flywheel generator module that has been designed by Pratitis *et al.*, [5] and by varying the flywheel in order to investigate the effect of the flywheel addition. The generator set module design, as shown in the Figure 2, is composed by the

aluminum frame (1), the flywheel (2), the alternator or generator (3), the electromotor (4), the flywheel shaft (5) and the pulley transmissions (6-8).



**Fig. 2.** Generator set module design [5]

The application of the flywheel in the generator set system is the main analysis point in this experimental study. Thus, two kinds of flywheel with different mass and geometry are used to study the effect of the rotational kinetic energy of the flywheel in the genset system. The flywheel type and specification are shown in Figure 3 and Table 1.



**Fig. 3.** (a) Flywheel type A, (b) Flywheel type B

**Table 1**  
 The specification of flywheel

	Flywheel A	Flywheel B
Mass	8.5 kg	16 kg
Diameter	34 cm	40 cm
Height	2.1 cm	3 cm

Besides the flywheel, the genset system also composed of the electromotor and alternator. The electromotor is used to convert the electrical energy into the mechanical energy. The mechanical energy is then transmitted by using the pulley transmission to rotate the alternator to generate the electricity. This experimental study uses a 1-phase, 1.1 kW electromotor with 1400-1435 nominal rpm and a 1-phase synchronous generator with 1440-1500 nominal rpm.

### 3.2 System Simulation and Data Compiling

The gen-set system is simulated in three conditions : (1) unloaded condition, (2) loaded with one set of drilling machine and (3) loaded with two sets of drilling machines, and by using three kind of variations : (1) no flywheel, (2) using type A flywheel and (3) using type B flywheel. Several data are compiled and then analyzed and correlated with the rotational kinetic energy theory in order to study the effect of the application of the flywheel in the genset system. The data include

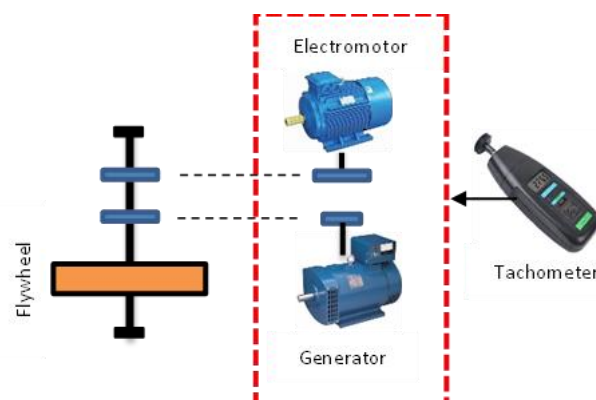
- i. The electromotor current test when it is in unloaded and loaded condition, with (1) the non-flywheel variation, (2) the type A flywheel and (3) the type B flywheel.
- ii. The electromotor rotation speed test (rpm test) when it is in unloaded and loaded, with (1) the non-flywheel variation, (2) the type A flywheel and (3) the type B flywheel.
- iii. The generator rotation speed test when it is in unloaded and loaded with (1) the non-flywheel variation, (2) the type A flywheel and (3) the type B flywheel.
- iv. The system stopping time test

## 4. Result and Discussion

The analysis of this experimental study is divided into 2 parts : the rotational kinetic energy analysis and the electromotor current test and the system time-to-stop test analysis.

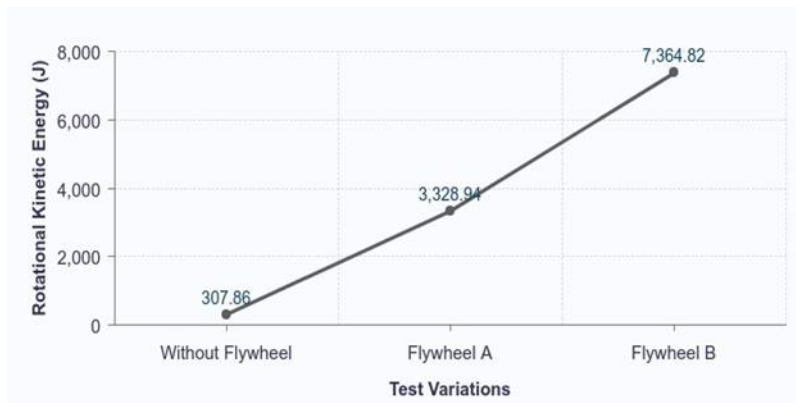
### 4.1 Rotational Kinetic Energy Analysis

The results and analysis of rotational kinetic energy are based on the data from the electromotor rotation rotational speed test, the generator rotational speed test and flywheel rotational speed test by using the tachometer (as shown in Figure 4) when the generator is in unloaded and loaded conditions with the non-flywheel variation, with the type A flywheel (8.5 kg) and the type B flywheel (16 kg). The test results are then processed into the rotational kinetic energy data using the Eq. (3).



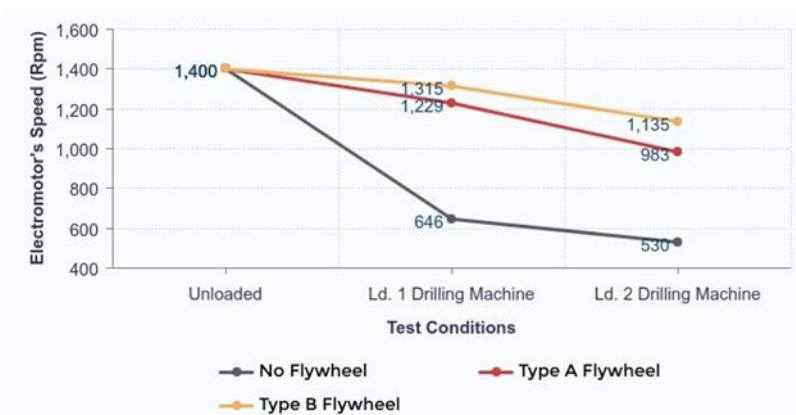
**Fig. 4.** The schematic of the electromotor and the generator rotational speed test

Based on the Figure 5, it can be observed that by adding the flywheel, the rotational kinetic energy of the system increases. It is shown by the increasing trend line when the flywheel is applied. The rotational kinetic energy increases when the flywheel with a bigger mass is used. This is indicated when type A flywheel with a mass of 8.5 kg is used, the rotational kinetic energy of the system is 3328.94 J, and it is increased to 7364.82 J when the type B flywheel with mass of 16 kg is applied.

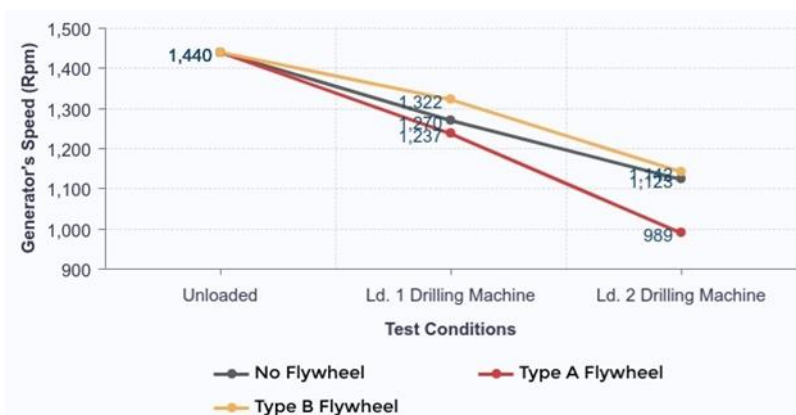


**Fig. 5.** The rotational kinetic energy of the system

The application of the flywheel also affects the rotational speed of electric motor and the generator when given a load. The results of the electromotor and the generator rotational speed test with the non-flywheel variation shows that the greater the load given to the generator, the more the rotational speed of the generator and the electric motor decreases. This is proven by the Figure 6 and Figure 7 when the load is getting closer to the nominal power of the electric motor, the rotational speed of the electric motor is only 530 rpm out of 1400 rpm and the generator decreased to 1123 rpm from the nominal rotation speed of 1440 rpm.



**Fig. 6.** The electromotor speed test result



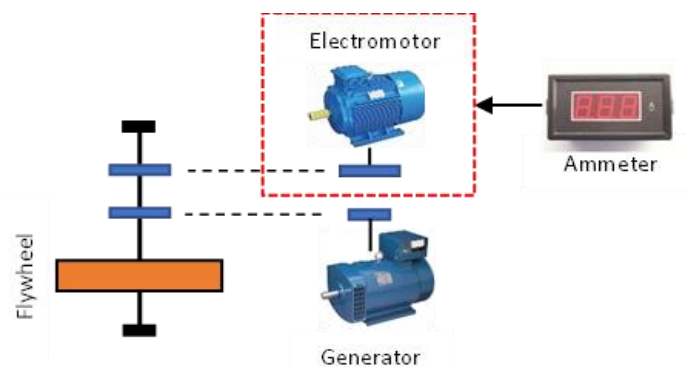
**Fig. 7.** The generator speed test result



In the type A and B flywheel variations, the rotational speed of the electromotor and the generator has better magnitude compared with the non-flywheel variation. From the three test variations, the type B flywheel has better electromotor and generator rotational speed which are closer to their nominal speed. This shows that the application of type B flywheel to the genset system causes a greater rotational kinetic energy, so that the fluctuation of the rotational speed of the electromotor and the generator is decreasing and the genset system is getting more stable, because the electromotor and the generator are closer to their nominal speed.

#### 4.2 Electromotor Current and System Stopping Time Analysis

Based on the rotational kinetic energy analysis, the kinetic energy that is typically stored in the system can be correlated to the electromotor current and the system stopping time. The results of the electromotor current test shows that the non-flywheel variation experiences a fair increase in its current, i.e. from 3.5 A under the unloaded condition and rises to 4.8 A when given a load of 1 kW of two sets of drilling machines which are close to the nominal power of the electromotor. When the gen-set system is connected to the variation of type A and B flywheels, there is a slight current increase compared with the non-flywheel variation when the generator is given a load close to the nominal power of the electric motor in which proven by the Figure 8. The fewest current increase occurs when the type B flywheel variation is used and when the generator is given a load close to the nominal power of the electric motor, there is only a slight current increase of 0.5 A from the initial value of 3.5 A to 4 A. The current increase of the electric motor indicates that the work of the electric motor is getting heavier because of the load given, especially when the load is getting closer to the nominal power of the electric motor. This impacts on the reduction of the rotational speed of the electric motor as well as the rotational speed of the generator.



**Fig. 8.** The schematic of the electromotor current test

Based on the Figure 9, The application of the flywheel to the gen-set system eases the workload of the electric motor. When the generator is given a load, which is closer the nominal power of the electromotor, the rotational speed of the electromotor decreases due to the heavy workload. The role of the flywheel, as shown by the results of the rotational speed test of the electromotor, helps the electromotor stabilize its speed which in return also stabilizes the rotational speed of the generator as well, as indicated in the results of the generator rotational speed test.

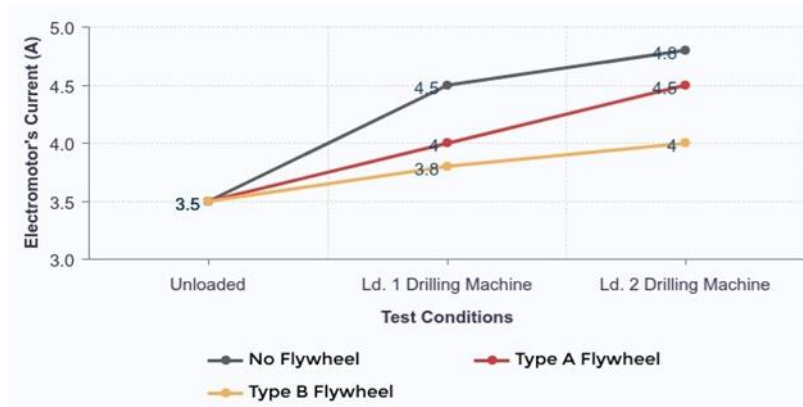


Fig. 9. The electromotor current test result

Furthermore, the electrical power that is used by the electromotor is also reduced when the electromotor has a lighter workload in which it is evidenced by the smaller magnitude of the electric current when the flywheel is applied. Therefore, the electromotor becomes more efficient when the electromotor uses less electrical power.

As shown in the Figure 10, the gen-set system in which the type B flywheel is applied has a longer stopping time when the electrical power supply is removed, about 70 seconds, than the type A flywheel variation which has 24 seconds and the non-flywheel variation with only 13 seconds of stopping time. This indicates that the application of the flywheel helps the gen-set system to maintain its rotational speed while it is operated or even when the power supply is removed for a certain time interval because of the rotational kinetic energy that is stored and released by the flywheel itself.

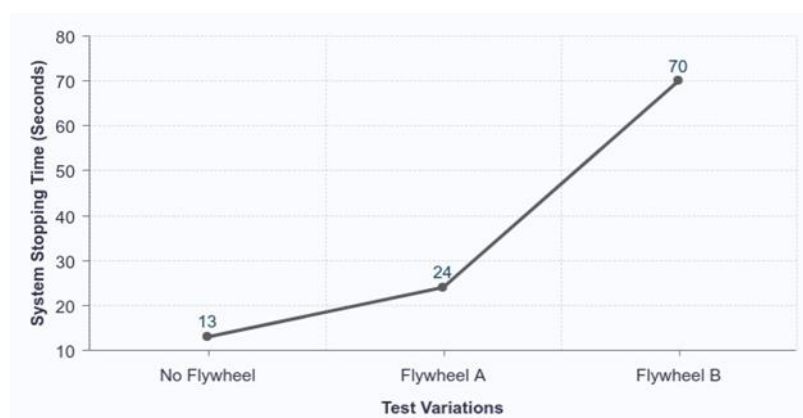


Fig. 10. The system stopping time test result

## 5. Conclusion

Referring to above explanation, it can be concluded that the application of the flywheel on the generator set helps the system stabilizes its output under a heavier load in which it is proven by the fewer reduction of the electromotor and the generator rotational speed as shown in the Figure 5 and 6. The addition of the flywheel also lightens the workload of the system as indicated by the smallest increase rate of the electromotor current usage under a loaded condition as proven in the Figure 7. The rotational kinetic energy that is stored inside the flywheel also helps the gen-set system to maintain its rotational speed while it is operated under a loaded condition or even when the power supply is removed as proven the system stopping time test and the Figure 8. Therefore, the expected research result is achieved and the flywheel can stabilize the gen-set system.



## Acknowledgement

The authors would like to thank Assoc. Prof Sheikh Ahmad Zaki of the Department of Mechanical Precision Engineering of Malaysia-Japan International Institute of Technology, Universiti Teknologi Malaysia for his supervision and Drs. Sudarno, M.H from Indonesia as the personal English expert.

## References

- [1] Benton, Kelly, Xufei Yang, and Zhichao Wang. "Life cycle energy assessment of a standby diesel generator set." *Journal of Cleaner Production* 149 (2017): 265-274. <https://doi.org/10.1016/j.jclepro.2017.02.082>
- [2] Zhang, Z., K. Sato, Y. Nagasaki, M. Tsuda, Daisuke Miyagi, T. Komagome, K. Tsukada, T. Hamajima, Y. Ishii, and D. Yonekura. "Continuous operation in an electric and hydrogen hybrid energy storage system for renewable power generation and autonomous emergency power supply." *International Journal of Hydrogen Energy* 44, no. 41 (2019): 23384-23395. <https://doi.org/10.1016/j.ijhydene.2019.07.028>
- [3] Lyman, Dale. "Chapter 8 : Emergency power, supplies and electrical systems." *Ambulatory Surgery Center Safety Guidebook*, p 37-41. 2018. <https://doi.org/10.1016/B978-0-12-849889-7.00008-X>
- [4] Zhang, Z., Y. Nagasaki, D. Miyagi, M. Tsuda, T. Komagome, K. Tsukada, T. Hamajima, H. Ayakawa, Y. Ishii, and D. Yonekura. "Stored energy control for long-term continuous operation of an electric and hydrogen hybrid energy storage system for emergency power supply and solar power fluctuation compensation." *International Journal of Hydrogen Energy* 44, no. 16 (2019): 8403-8414. <https://doi.org/10.1016/j.ijhydene.2019.02.076>
- [5] Yuniarsih, Pratitis, Fahmi Bachtiyar, Mufti Rosyidin, and Trisakti Prabawanto. "Flywheel Generator." In *Pekan Ilmiah Mahasiswa Nasional Program Kreativitas Mahasiswa-Teknologi 2014*. Indonesian Ministry of Research, Technology and Higher Education, 2014.
- [6] Shakti Foundation. "Diesel generators : Improving efficiency and emission performance in India."
- [7] Diesel service and Supply. "Factors affecting generator output rating."
- [8] Lee, Seokhwan, Young Choi, and Kernyong Kang. "Application of blended fuel containing coffee ground pyrolysis oil in a diesel generator." *Fuel* 256 (2019): 115998. <https://doi.org/10.1016/j.fuel.2019.115998>
- [9] Semshchikov, Evgenii, James Hamilton, Liuer Wu, Michael Negnevitsky, Xiaolin Wang, and Sarah Lyden. "Frequency control within high renewable penetration hybrid systems adopting low load diesel methodologies." *Energy Procedia* 160 (2019): 483-490. <https://doi.org/10.1016/j.egypro.2019.02.196>
- [10] Aminudin, Moh. Syaikhu, Sarwono and Ridho Hantoro. "Studi aplikasi flywheel energy storage untuk peningkatan dan menjaga kestabilan pembangkit listrik tenaga mikrohidro (PLMTH)." *Institute Teknologi Sepuluh Nopember Surabaya*. 2010.
- [11] Akinyele, Daniel O., and Ramesh K. Rayudu. "Review of energy storage technologies for sustainable power networks." *Sustainable energy technologies and assessments* 8 (2014): 74-91. <https://doi.org/10.1016/j.seta.2014.07.004>
- [12] Köhler, Jonathan, Wolfgang Schade, Guillaume Leduc, Tobias Wiesenthal, Burkhard Schade, and Luis Tercero Espinoza. "Leaving fossil fuels behind? An innovation system analysis of low carbon cars." *Journal of Cleaner Production* 48 (2013): 176-186. <https://doi.org/10.1016/j.jclepro.2012.09.042>
- [13] Longo, Sonia, Vincenzo Antonucci, Maurizio Cellura, and Marco Ferraro. "Life cycle assessment of storage systems: the case study of a sodium/nickel chloride battery." *Journal of Cleaner Production* 85 (2014): 337-346. <https://doi.org/10.1016/j.jclepro.2013.10.004>
- [14] Wicki, Samuel, and Erik G. Hansen. "Clean energy storage technology in the making: An innovation systems perspective on flywheel energy storage." *Journal of cleaner production* 162 (2017): 1118-1134. <https://doi.org/10.1016/j.jclepro.2017.05.132>
- [15] Khurmi, R. S., and J. K. Gupta. *A textbook of machine design*. S. Chand publishing, 2005.
- [16] Ilmiawan, Fakhri Akbar, Joke Pratilastiarso, and Prima Dewi Permatasari. "Studi Eksperimen Aplikasi Flywheel Pada Pembangkit Listrik Untuk Daerah Terpencil." In *Prosiding Seminar Nasional Teknologi Elektro Terapan*, vol. 1, no. 01, pp. 181-186. 2017.
- [17] Han, Yongjie, Zhengyi Ren, and Yongxiang Tong. "General design method of flywheel rotor for energy storage system." *Energy Procedia* 16 (2012): 359-364. <https://doi.org/10.1016/j.egypro.2012.01.059>
- [18] Hadjipaschalis, Ioannis, Andreas Poullikkas, and Venizelos Efthimiou. "Overview of current and future energy storage technologies for electric power applications." *Renewable and sustainable energy reviews* 13, no. 6-7 (2009): 1513-1522. <https://doi.org/10.1016/j.rser.2008.09.028>
- [19] Doucette, Reed T., and Malcolm D. McCulloch. "A comparison of high-speed flywheels, batteries, and ultracapacitors on the bases of cost and fuel economy as the energy storage system in a fuel cell based hybrid

- electric vehicle." *Journal of Power Sources* 196, no. 3 (2011): 1163-1170. <https://doi.org/10.1016/j.jpowsour.2010.08.100>
- [20] Boroogeni, Kianoosh G., M. Hadi Amini, and Sundararaja S. Iyengar. *Smart grids: security and privacy issues*. Vol. 221. Cham, Switzerland: Springer International Publishing, 2017. <https://doi.org/10.1007/978-3-319-45050-6>
- [21] Bergek, Anna, Marko Hekkert, Staffan Jacobsson, Jochen Markard, Björn Sandén, and Bernhard Truffer. "Technological innovation systems in contexts: Conceptualizing contextual structures and interaction dynamics." *Environmental innovation and societal transitions* 16 (2015): 51-64. <https://doi.org/10.1016/j.eist.2015.07.003>
- [22] Bai, J. G., X. Z. Zhang, and L. M. Wang. "A flywheel energy storage system with active magnetic bearings." *Energy Procedia* 16 (2012): 1124-1128. <https://doi.org/10.1016/j.egypro.2012.01.179>
- [23] Jewett, John W., Raymond A. Serway, and Vahé Perroomian. *Physics for scientists and engineers with modern physics*. Brooks/Cole, 2010.