

Transformation of Carbon Dioxide into Methanol

Nurjehan Ezzatul Ahmad^{1,*}, Maizirwan Mel^{1,*}, Fatin Nabilah Murad¹, Nur Amalina Ramli¹, Zulaika Muhamad Sade¹, Ima Shahanaz Ahmad Zailani¹, Mohd Sharul Amri Rosmadi¹, Hamzah Mohd Salleh¹

¹ Department of Biotechnology Engineering, Faculty of Engineering, International Islamic University, Malaysia (IIUM), PO Box 50278, Kuala Lumpur, Malaysia

ARTICLE INFO

Article history:

Received 26 August 2018

Received in revised form 12 October 2018

Accepted 14 October 2018

Available online 3 December 2018

ABSTRACT

Due to high potential of pollution risk of the untreated palm oil mill effluent (POME), it can be treated and converted into methane gas and with a further conversion that can produce into methanol. Previously, methanol is widely used in domestic and industrial applications as a solvent. It has a unique characteristic, which are colourless, flammable, volatile, odourless liquid that is readily miscible in water and has boiling point approximately 64.5°C. Nowadays, the methanol has more been used in transportation and energy production. In future, it is predicted that the use of methanol in fuel applications will generate a huge demand. This study targets to design the process of transforming carbon dioxide, captured from the biogas through anaerobic digestion into synthesizing the methanol with the aim to produce 200 tonnes of methanol per year. This expectation is due to several advantages offered by the use of methanol, which less polluted to the environment, economically attractive, less flammable, high performance with high calorific value and thus become the focus of research nowadays.

Keywords:

POME, Biogas, Carbon dioxide, Methanol

Copyright © 2018 PENERBIT AKADEMIA BARU - All rights reserved

1. Introduction

Energy produced from fossil fuel can be detrimental to our nature due to harmful emission of carbon dioxide. Due to its limited resources, the price and high cost of production, the energy from fuel cells becoming more expensive. People opt to alternatives for the replacement of fossil fuel for clean and affordable energy sources. In years to come, biogas will be the most feasible alternative replacement for fossil fuel. It is cheap and green energy to the environment, by reducing the emission of heat and methane gas of the natural sources for biogas production which are landfill, animal manure, wastewater, organic waste, and many more [1].

* Corresponding author.

E-mail address: nrjehanahmad@gmail.com (Nurjehan Ezzatul Ahmad)

* Corresponding author.

E-mail address: maizirwan@iium.edu.my (Maizirwan Mel)

The energy demand worldwide is growing rapidly, and around 88 per cent of this demand is met at present time by fossil fuels. There are expectations that the energy demand will increase by a factor of two or three during this century. Biogas can be produced from wastes, residues, and energy crops will have a significant role and importance in the future [2]. To begin with, biogas is recognized as a versatile renewable source of energy. The only time it will be depleted is when we stop producing any waste since it often produces from materials that form sewage and waste products. Biogas is also non-polluting in nature. There is no oxygen requirement in the production of biogas [3]. This means that resources are conserved as it is not using any further fuel. By utilizing the gases being produced in landfills as forms of energy, it can reduce the greenhouse effect. This is a primary reason why the use of biogas has started to catch on. Most of the biodegradable wastes can be recycled and it works on simple forms of technology. Biogas plant is easy to set up and requires only little capital investment on a small-scale basis.

The easiest way to use biogas is heating. This is because, besides removing the water, there is no pre-treatment is required for this purpose. Biogas is usually used for heating buildings as well as a biogas plant. The surplus heat can also be directed into the district heating network. The energy of biogas can be utilized to generate power. With the help of a gas-powered generator, both electricity and heat can be produced. Many industries such as sugar refineries, distilleries, dairies and paper mills generate processing and waste water that can be digested directly on site [4]. Thus, biogas can be used for heating premises, district heating power production and so forth.

In many countries, biogas is considered as an alternative to diesel and gasoline that has an environmentally attraction to operate any types of transportation [5]. Methane-powdered engines generate lower sound level the exhaust fume emissions are also lower if compared diesel engines. Others, the emission of nitrogen oxides is very low. However, in order to be used as vehicle fuel, biogas requires a considerable processing. The energy value must be raised to achieve a methane content of between 95 per cent and 99 per cent by separating carbon dioxide [6]. Water, impurities and particles must be removed to avoid mechanical and environmental damage. Finally, the gas must be compressed. Although significant works have to be implied to upgrade methane gas to biogas fuel, the environmental benefits are so great compared to the others. It can be proved with the increasing number of filling stations are opening throughout the country every year.

In this study, palm oil mill effluent (POME) are used as the feed for biogas production. Major product from biogas is methane. The biogas produced contains usually 50 to 65 percent of methane, whereas carbon dioxide takes up to 35 to 50 per cent [2,7]. However, variation of proportion for methane and carbon dioxide keep increasing with the duration and extent of bio methanation over retention time. At every 1000 liters of biogas production, 400 liters of CO₂ will be produced. From here, it clearly shows that the high emission of CO₂ gas from the biogas production may cause a critical issue [3].

Therefore, in this study, CO₂ are captured and converted into methanol to reduce the problems of greenhouse effect.

2. Methodology

The process involves are illustrated in Figure 1. POME undergo the anaerobic digestion process where it is a decomposition process of using different species of anaerobic microorganisms in the process of degradation of organic matter [8,9]. Then, the gases produce from anaerobic digestion process are feed in into absorption column to remove H₂S, NH₃ and CH₄. CO₂ are compressed into liquid before feeding in into methanol reactor for production of methanol. Then, the methanol entering the distillation column to remove remaining water and to obtain purified methanol.



Fig. 1. Process flow diagram for conversion of raw POME to purified methanol

The process condition for each unit operations are shown in Table 1.

Table 1
 Process condition of unit operations involved

Unit operation	Process conditions		
	Function	Pressure	Temperature
Anaerobic digester	Conversion of POME to biogas	2 bar	55°C
Absorption column 1	H ₂ S and ammonia removal	8 bar	60°C
Absorption column 2	Carbon dioxide removal	8 bar	60°C
Stripper column	Carbon dioxide removal	8 bar	60°C
Compressor	Compress CO ₂ gas into liquid CO ₂	10 bar	60°C
Methanol synthesis	Synthesis of methanol	60 bar	250°C
Distillation column 1	Removal of CO ₂ and H ₂	0.8 bar	70°C
Distillation column 2	Removal of H ₂ O	0.8 bar	70°C

The target product is 200 tonnes per year. Hence, by backward calculation as shown in Equation 1, 20.712 kg/h POME are required.

$$(200 \text{ tonnes per year}) \left(\frac{907.185 \text{ kg}}{1 \text{ tonnes}} \right) \left(\frac{1 \text{ year}}{365 \text{ day}} \right) \left(\frac{1 \text{ day}}{24 \text{ h}} \right) = 20.712 \text{ kg/h} \quad (1)$$

All reactions in the anaerobic digester are determined empirically based on Buswell's equation:

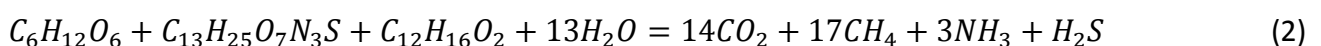

It is assumed that from the anaerobic digester, the total composition of component in outflow gas are 30 per cent, 60 per cent, 0.3 per cent, 1 per cent and 8.7 per cent of CO₂, CH₄, H₂S, NH₃ and water, respectively. After the separation process in the H₂S scrubber [10] where the H₂S are

absorbed by the solvent (NaOH) [11], there are about 2 per cent to 5 per cent of CO₂ and CH₄ are still in the residual stream and the gas released are the treated biogas contains CO₂ and CH₄. About 96 per cent purity of CH₄ in the outlet methane stream from the water scrubber. It is assumed that after water scrubbing, CH₄ and CO₂ will separate completely. About 96 per cent of aqueous CO₂ released and entered stripper column. It is assumed that CO₂ and water in stripper column is completely separated. CO₂ gas are compressed into liquid CO₂ and being feed in into packed bed reactor with a catalyst Cu-ZnO/Al₂O₃. In the packed bed reactor, H₂ are feed in and 95 per cent of conversion of liquid CO₂ and H₂ can be achieved to produce crude methanol, CH₃COH. The composition of methanol in crude methanol is 91 per cent while water is 9 per cent.

The crude methanol entering the distillation column to remove remaining CO₂ and H₂. In the first distillation column, it boiled at a lower temperature than the boiling point of the methanol, where by the differences in temperature, the crude methanol and CO₂ with H₂ will be separated, and this process known as topping process. The removal of CO₂ increases the purity of methanol to 91 per cent. The product leaving from the first distillation column are transferred to the second distillation column to get a high purity of methanol. The second distillation column also known as refining column. In this step, the methanol liquid is constantly boiled until the water is separated from the product, methanol. The methanol boils faster than water as it has a lower boiling temperature than water. Methanol leaves the top of the column while the bottom contains mainly of water and small traces of other gases. Condenser is inserted at the top of the column so that the methanol vapor can be separated and rises to the top. At the bottom part, a reboiler is set up to recycle the water leaving to the outside of the column by re-boiling it to get the least composition of methanol in the bottom. The purity of the methanol that are purified was up to 95 per cent.

3. Results

Simulation process has been done in the Aspen HYSYS V9 simulator to simulate the process of transforming the carbon dioxide into methanol as shown in Figure 2.

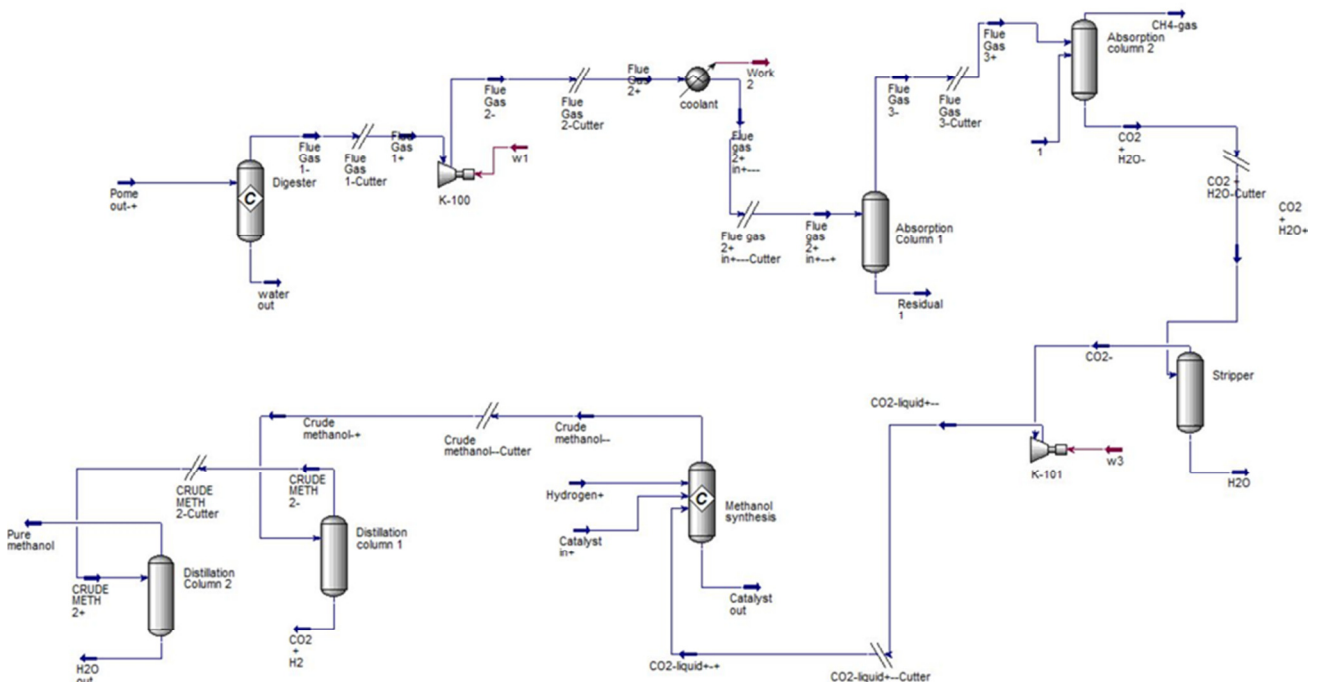

Fig. 2. Process flowsheet of conversion of raw POME to purified methanol in the Aspen HYSYS V9 simulator

As shown in the Figure 2, there are anaerobic digester, absorption column, stripper column, methanol synthesis reactor and distillation column involved. From the process, methanol is obtained after the purification process of crude methanol in the distillation column.

From the unit operations designed, production of 200 ton of methanol per year by the conversion of carbon dioxide with addition of hydrogen can be obtained. According to previous study, biogas composition released from anaerobic digestion on POME comprise of 60 per cent of methane gas, 39 per cent carbon dioxide gas and another 1 per cent gases include H₂S, NH₃ and water. Therefore, instead of releasing the CO₂ gas into the atmosphere, another alternative is capturing the CO₂ gas to produce pure methanol as energy sources [12, 13]. Equation 3 below is used to calculate the amounts of product obtained from each unit operation involved.

$$Mass\ in\ (F_{in}) = Mass\ out\ (F_{out}) \tag{3}$$

Table 2 indicate the result of the conversion from feed which is POME at 44.938 kg/h and produce pure methanol at 20.712 kg/h with all the unit operations involved.

Table 2
 Result of mass flow rate of feed and product

Unit operation	Feed	Product
Anaerobic digester	POME = 44.938 kg/h Glucose = 8.313 kg/h Protein = 16.950 kg/h Lipids = 8.863 kg/h Water = 10.807 kg/h Total = 44.938 kg/h	Biogas = 44.938 kg/h NH ₃ = 2.355 kg/h CO ₂ = 28.450 kg/h H ₂ S = 1.570 kg/h CH ₄ = 12.562 kg/h Total = 44.937 kg/h
Absorption column 1	Biogas = 44.938 kg/h NH ₃ = 2.355 kg/h CO ₂ = 28.450 kg/h H ₂ S = 1.570 kg/h CH ₄ = 12.562 kg/h Total = 44.937 kg/h	Mixed CO ₂ and CH ₄ = 41.012 kg/h Residual gas = 3.925 kg/h Total = 44.937 kg/h
Absorption column 2	Mixed CO ₂ and CH ₄ = 41.012 kg/h Water = 100 kg/h Total = 141.012 kg/h	Mixed CO ₂ and H ₂ O = 128.450 kg/h Methane = 12.562 kg/h Total = 141.012 kg/h
Stripper column	Mixed CO ₂ and H ₂ O = 128.450 kg/h Total = 128.450	CO ₂ = 28.450 kg/h H ₂ O = 100 kg/h Total = 128.450 kg/h
Compressor	CO ₂ Gas = 28.450 kg/h Total = 28.450 kg/h	CO ₂ Liquid = 28.450 kg/h Total = 28.450 kg/h
Methanol synthesis	CO ₂ Liquid = 28.450 kg/h H ₂ = 3.880 kg/h Total = 32.330 kg/h	Crude Methanol = 32.330 kg/h Total = 32.330 kg/h
Distillation column 1	Crude Methanol = 32.330 kg/h Total = 32.330 kg/h	Liquid stream: Crude Methanol = 32.330 kg/h Gas stream: CO ₂ and H ₂ = 1.702 (unreacted) Total = 32.330 kg/h
Distillation column 2	Liquid stream : Crude Methanol = 32.330 kg/h Total = 32.330 kg/h	Liquid stream: H ₂ O = 11.618 kg/h Gas stream: Pure Methanol = 20.712 kg/h Total = 20.712 kg/hr

The processing of fresh fruit bunches of oil palm results in the generation of different types of residue. Among all the waste generated, palm oil mill effluent (POME), which is considered as the

most harmful waste for the environment if discharge untreated. POME is a thick brownish liquid that contains high amounts of solids, oil and grease, chemical oxygen demand (COD) and biochemical oxygen demand (BOD) values. Due to the presence of high total solids in POME, attempts have been made to convert this waste into valuable products such as feedstock, where focusing POME as biogas feedstock to obtain CH₄ and CO₂. CO₂ is the major part of global warming issue, hence, CO₂ that emits from the digester are captured to avoid contribution into global warming problem.

There are four different stages involves in the anaerobic digestion process for the production of biogas [2] which are hydrolysis, acidogenesis, acetogenesis and methanogenesis, where in hydrolysis, microbes hydrolyse complex molecules in the waste into simple building blocks. While the acidogenesis bacteria convert these into organic acids and acetic acid is formed then by acetogens. Lastly, the acetic acid being taken up by methanogenesis microbes to make CH₄ and CO₂.

All reactions in the anaerobic digester are determined empirically based on Buswell's equation.

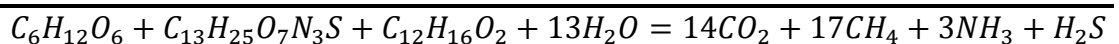
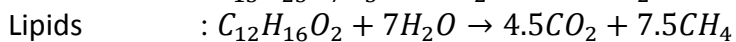
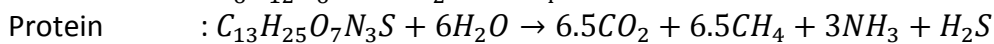
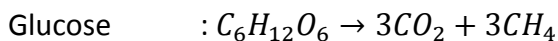
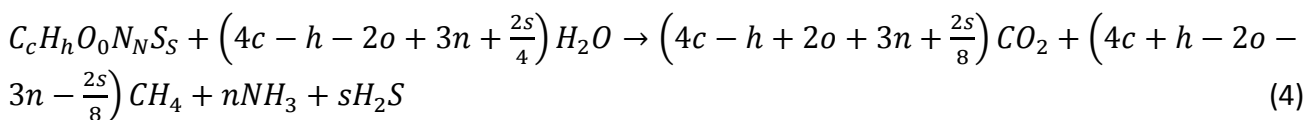

From the reaction, it shows that biogas is produced after the anaerobic digestion of the POME. Biogas is innocuous to our environment and the answer to mitigate most of general environment problems associated with global warming and air pollution. In biogas, which primarily contain 65 per cent of CH₄ and 35 per cent of CO₂, only CH₄ are being used and the CO₂ are being released into the atmosphere. With the 35 per cent of CO₂ in biogas, it is abundant source of CO₂ which can be used properly in the industry.

Methanol has been widely used nowadays since people start to aware about the advantages of methanol. The use of methanol is because of it is less polluted to the environment, economically attractive, less flammable and high performance with high calorific values. In previously, it has used in the domestic and industrial applications as a solvent. Nowadays, it is use more in transportation and energy production [14]. And in future, it is predicted that the use of the methanol in biofuel applications will generate a huge demand. After several processes [15], for examples separation of CH₄ and CO₂, and increase in the purity of the CO₂ concentration, CO₂ react with H₂ to produce methanol with the chemical formula CH₃OH and it is known as the most basic alcohol that exist. The reaction involves for production of methanol known as carbon dioxide hydrogenation where it required hydrogen supply.

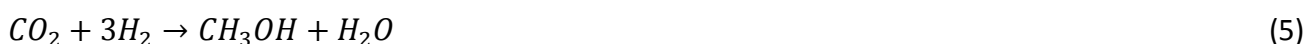

By capturing the carbon dioxide, the greenhouse effect can be reduced since the emission of greenhouse gases is reduced as well. Compared the conversion of methanol to the methanation process, methanol conversion consumes less hydrogen and easy to be stored since it has higher energy density. The conversion of methanol from carbon dioxide hydrogenation required catalyst to ensure higher selectivity.

The crude methanol mixture from the synthesis loop must be purified to meet the final specification in purity. There is crude methanol storage tank where it will become the feed to the next part of unit operation, which is purification by distillation [15]. Distillation is a method of separating mixtures based on difference in volatilities. At this stage, crude methanol usually contains approximately 18 per cent of water along with other impurities. Besides reducing water content in the methanol, it is essential for crude methanol to be stabilized by removing volatile components such as carbon dioxide. This stabilized methanol permits shipment and transport in atmospheric vessels in a more economical way by reducing the cost [14]. Separation of components in the crude methanol also depends on the commercial uses of methanol currently range widely.

4. Conclusions

Hence, with production of 20.71 kg/h of methanol, 200 tonnes of methanol can be produced in a year. Methanol has been widely used nowadays since people start to aware about the advantages of methanol. Therefore, there will be a huge demand of methanol in the industry especially where the source of methanol is from biogas, due to the abundance of biogas and it less polluted to the environment. According to Islamic point of view, there is a hadith stated that "*The earth is green and beautiful, and Allah has appointed you his stewards over it*" which reiterates Quran teaching that human beings have been given the responsibility of guardianship over the natural environment. Hence, this study is an ideal approach because it able to bring benefit to the world.

References

- [1] Abdurahman, N. H., Y. M. Rosli, and N. H. Azhari. "The performance evaluation of anaerobic methods for Palm Oil Mill Effluent (POME) treatment: A review." In *International perspectives on water quality management and pollutant control*. InTech, 2013.
- [2] Sinaga, N, Nasution, S.B., Mel, M. "Process Optimization of Biogas Production from Palm Oil Mill Effluent. A Case Study of a Crude Palm Oil Factory in Muaro Jambi, Indonesia." *Journal of Advanced Research in Fluid Mechanics and Thermal Sciences* 49, no. 2 (2018): 155-169.
- [3] Metz, Bert, Ogunlade Davidson, H. C. De Coninck, Manuela Loos, and L. A. Meyer. "IPCC, 2005: IPCC special report on carbon dioxide capture and storage. Prepared by Working Group III of the Intergovernmental Panel on Climate Change." *Cambridge, United Kingdom and New York, NY, USA* 442 (2005).
- [4] Zanganeh, Kourosh E., Ahmed Shafeen, and Carlos Salvador. "CO₂ capture and development of an advanced pilot-scale cryogenic separation and compression unit." *Energy Procedia* 1, no. 1 (2009): 247-252.
- [5] Ahouari, Hania, Ahcène Soualah, Anthony Le Valant, Ludovic Pinard, Patrick Magnoux, and Yannick Pouilloux. "Methanol synthesis from CO₂ hydrogenation over copper based catalysts." *Reaction Kinetics, Mechanisms and Catalysis* 110, no. 1 (2013): 131-145.
- [6] Khirsariya, Priyank, and Raju K. Mewada. "Single step oxidation of methane to methanol—towards better understanding." *Procedia Engineering* 51 (2013): 409-415.
- [7] Zhao, Q., E. Leonhardt, C. MacConnell, C. Frear, and S. Chen. "Purification technologies for biogas generated by anaerobic digestion." *Compressed Biomethane, CSANR, Ed* (2010).
- [8] Côté, Caroline, Daniel I. Massé, and Sylvain Quessy. "Reduction of indicator and pathogenic microorganisms by psychrophilic anaerobic digestion in swine slurries." *Bioresource Technology* 97, no. 4 (2006): 686-691.
- [9] Ahmad, N.E, Mel M, and Sinaga, N. "Design of Liquefaction Process of Biogas using Aspen HYSYS Simulation." *Journal of Advanced Research in Biofuel and Bioenergy* 2, no. 1 (2018): 10-15.
- [10] Nock, William J., Mark Walker, Rimika Kapoor, and Sonia Heaven. "Modeling the water scrubbing process and energy requirements for CO₂ capture to upgrade biogas to biomethane." *Industrial & Engineering Chemistry Research* 53, no. 32 (2014): 12783-12792.
- [11] Salazar, Juan, Urmila Diwekar, Kevin Joback, Adam H. Berger, and Abhoyjit S. Bhowan. "Solvent selection for post-combustion CO₂ capture." *Energy Procedia* 37 (2013): 257-264.
- [12] Miguel, Carlos V., Miguel A. Soria, Adélio Mendes, and Luis M. Madeira. "Direct CO₂ hydrogenation to methane or methanol from post-combustion exhaust streams—A thermodynamic study." *Journal of Natural Gas Science and Engineering* 22 (2015): 1-8.

-
- [13] Van-Dal, Éverton Simões, and Chakib Bouallou. "Design and simulation of a methanol production plant from CO₂ hydrogenation." *Journal of Cleaner Production* 57 (2013): 38-45.
- [14] Witkowski, Andrzej, and Mirosław Majkut. "General physical properties of CO₂ in compression and transportation processes." In *Advances in Carbon Dioxide Compression and Pipeline Transportation Processes*, pp. 5-12. Springer, Cham, 2015.
- [15] Peters, Max Stone, Klaus D. Timmerhaus, Ronald Emmett West, Klaus Timmerhaus, and Ronald West. *Plant design and economics for chemical engineers*. Vol. 4. New York: McGraw-Hill, 1968.