

## Study of The Performance of The Gas Turbine Power Plants From The Simple To Complex Cycle: A Technical Review

Thamir Khalil Ibrahim<sup>1,\*</sup>, Mohammed Kamil Mohammed<sup>1</sup>, Wadhah Hussein Abdulrazzaq Al Doori<sup>1</sup>,  
Ahmed Tawfeeq Al-Sammarraie<sup>3</sup>, Firdaus Basrawi<sup>4</sup>

<sup>1</sup> Department of Mechanical Engineering, Tikrit University, Tikrit, Iraq

<sup>2</sup> Department of Mechanical and Nuclear Engineering, University of Sharjah, United Arab Emirates

<sup>3</sup> Department of Mechanical Engineering, University of California, Riverside, CA 92521, USA

<sup>4</sup> Faculty of Mechanical Engineering, Universiti Malaysia Pahang, 26600 Pahang, Malaysia

### ARTICLE INFO

#### Article history:

Received 10 February 2019

Received in revised form 17 March 2019

Accepted 2 April 2019

Available online 17 May 2019

### ABSTRACT

In this study, a comprehensive review of previous studies on GT power plants was conducted. The recent decades have witnessed several studies on the modelling and simulation of GT performance. This review concentrated on a simple cycle GT power plant (GTPP) with a 2-shaft, regenerative, reheat, intercooler, complex cycle GT with effect intercooler, regenerative and reheat. Further reviews focused on the influence of operating conditions on the performance of GTPP with more emphasis on the complex and simple cycles of the GT. Finally, the technical review focused on the improvement of the performance of the GTPP. However, information can be found on the assessment of the performance of GTPPs, especially, for GTPP operation in both ambient conditions and complex configurations. This review adopted a systematic approach to ensure that this study can be conducted properly to contribute to the existing information in this field.

#### Keywords:

Gas turbines, power plant, strategy,  
intercooler, regenerative, reheat

Copyright © 2019 PENERBIT AKADEMIA BARU - All rights reserved

## 1. Introduction

The first gas turbine built in 1903 by Aegidius Elling, a Norwegian, using rotary dynamic compressor and turbines marked the beginning of GT. This effort was credited with the building of the first GTPP that produced about 8kW [1]. This design was further improved by Elling in 1904 to operate at about 20 000 rpm and achieve about 33kW with an exhaust gas temperature of 773 K from the previous 673 K [2]. A practical GT was successfully built in 1905 by The Societe Anonyme des Turbomoteurs French Company when they assembled a GT [3,4]. At first, this engine was built to operate at constant pressure and under its own power, with an efficiency of 3%; the input to the machine was the fuel while useful shaft power was the output [1,5,6]. The engine was also built with a multistage centrifugal compressor of 20 or more stages, compressor efficiency of <60 %, pressure ratio of 4, and turbine inlet temperature of approximately 393°C [2,7-9]. However, several years

\* Corresponding author.

E-mail address: [thamirmathcad@yahoo.com](mailto:thamirmathcad@yahoo.com) (Thamir Khalil Ibrahim)

passed (until in 1939) before the establishment of a Brown Boveri (BBC) unit in Neuchatel, Switzerland, for emergency electric power supply. The efficiency of this unit was about 18% with an output of 4,000 kW. The first ever gas turbine set built with a single combustor is depicted in Figure 1. This unit operates at a turbine inlet temperature of 550°C, rotating at 3000 rpm, and generating about 15,400 kW. Out of this generated power rating, about 11000 kW were used to power the compressor of the system at an ambient temperature 20°C [10-13].

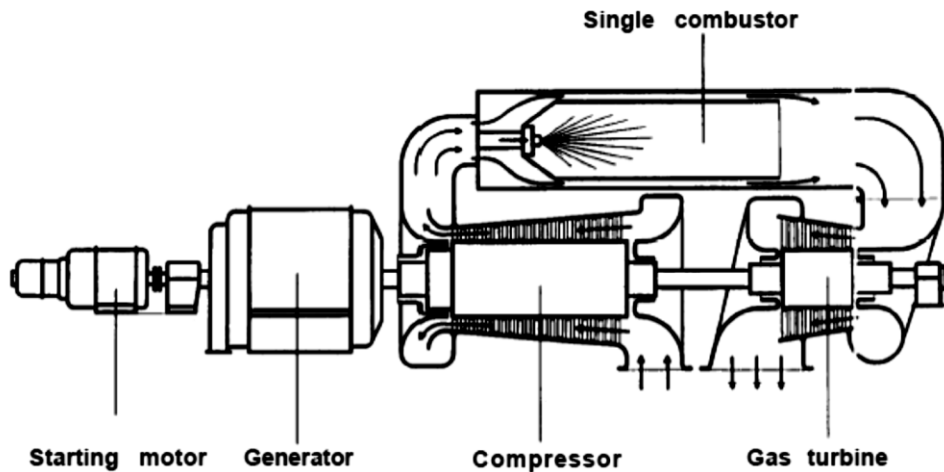

Fig. 1. The first ever built industrial GT set with a single combustor

In 1949, the first electric utility gas turbine built by General Electric (GE) Company as a part of a CCGT plant was installed in Oklahoma (USA) [1,14,15] with a power rating of about 3.5 MW. Until the mid-70s, the efficiency and reliability of this system were consistently low and poor [16,17]. In the 1990s, GE manufactured GTs with a pressure ratio of 13.5, power rating of 135.7 MW, and thermal efficiency of 33 % under a normal cycle operation. Recently, GE manufactured a GT that produced power of up to 300 MW at a turbine inlet temperature of 1425°C and a thermal efficiency 40 % under a normal cycle mode [18-21].

Recently, industrial mechanical power has been mainly produced from GTs in various industries; GT power has also been used in other power-driven activities such as driving of loads generators, propellers, process compressors, and pumps [22-24]. Initially, GT evolved as a relatively simple engine but has recently become a complex and dependable prime mover with high-efficiency [3, 25-27]. In most industries (such as in civil and military aviation, oil and gas production, and power generation), profitability depends on the performance and reliability of GTs [2,7]. The recent advancements in GTs have seen the compressor pressure ratio  $s$  increased from about 4:1 to more than 40:1, power output to around 350MW, operating temperatures of about 1800 K, and thermal efficiencies of >40 % [28,29].

## 2. Classification of Gas Turbines

Different arrangements of the GT components have developed in the past. Some of these arrangements are appropriate for power generation and the others used to mechanically drive applications such as compressors and pumps [2]. In this section, GT was classified based on the working cycle, components arrangements, and the field of application as follows:

## 2.1 Based on the Working Cycle

For CCGT and basic GT units, open cycle is the commonly used cycle. In this system, fresh air is continuously drawn into the circuit through an air compressor while energy is supplied to the system from the burning of fuel in the combustion chamber [30-32]. The waste gases and other products of the combustion process are expelled from the system into the air through the turbine as depicted in Figure 2(a) [6,33-35].

As in the open cycle of a GT, gases or working fluids are repeatedly circulated through the machine. The required energy in the system is added to a heat recovery while an auxiliary fan supplies the air required to burn the fuel [36-38]. Typically, the closed cycle of a GT resembles that of an ST plant by virtue of the gases produced from the combustion process not directly moving through the turbine as depicted in Figure 2(b) [39,40].

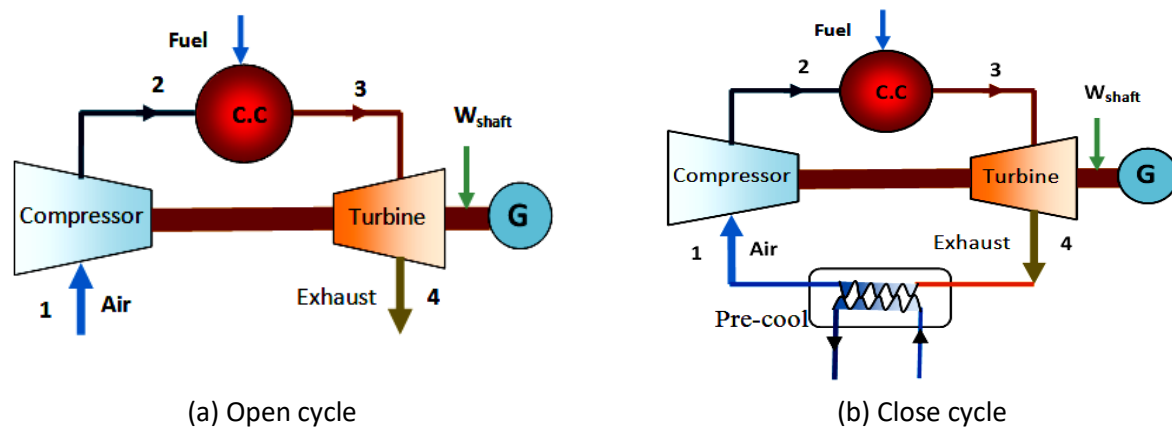
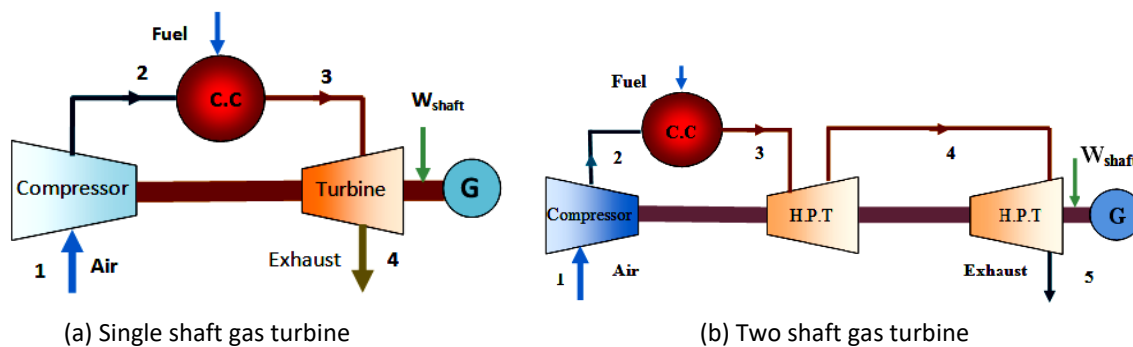

Fig. 2. Simple gas turbine cycles

## 2.2 Based on the Components Arrangement

As depicted in Figure 3, GTs can be designed based on either a single or two-shaft arrangement. The compressor and turbine of a single shaft gas turbine (SSGT) are both driven on a common shaft connected to a driver [41-43]. For the two-shaft or split shaft GT, a common shaft drives the compressor and the turbine while another shaft drives the free power turbine [44,45]. In this arrangement, the rotational speed of both shafts may vary to ensure a large extent of load control flexibility [31,46-48]. Often, the set comprised of the compressor, the combustion chamber, and the compressor-turbine in the split-shaft arrangement is usually referred to as the gas generator [40,49]. In the SSGT power plant, the compressors directly deliver compressed air into the combustion chamber for subsequent heating and mixing with the products of the combustion process at relatively constant pressure [50-54]. On entering the turbine of the GT, the hot gas expands and get expelled to the immediate environment via a chimney (Figure 3 (a)) [55,56]. About 60 % of the turbine power output from a GT plant is utilized by the compressor [10,13,57] while the rest is used to either power the generator or lost to the environment with the expelled gases [11,58].

When there is a need for load control flexibility, the two-shafts GTPP is deployed, such as in driving a road vehicle or the marine propeller as depicted in Figure 3(b) [33,59]. In this type of GT, the compressor is driven by a high-pressure turbine while the generator of the GT plant is driven by a low-pressure turbine [60-63]. A significant advantage of this system is that it can be started with ease compared to the SSGT plant while its drawback lies in the rapid shedding of electrical load which can cause the turbines to over-speed rapidly [64-66].



**Fig. 3.** The schematic representation of simple gas turbines

### 2.3 Based on the Field of Application

In terms of application, the aircraft industry accounts for the highest application of GTs as their ability to produce high-power output despite their low engine weight has made them the ideal propulsion system in aviation for both military and civilian purposes [67-69]. They have also found application as the ideal propulsion system in both ground armored and marine military equipment. The propulsion system of an aircraft is depicted in Figure 4 [70]. In the aviation field, a thermal jet engine is simply a jet propulsion device that depends on fuel combustion and air from its environment to produce the fluid jet used for propulsion purpose [71]. The period of the Second World War witnessed the basic development of jet engines when it was parallelly developed by Whittle and Von Ohain in England and Germany, respectively [1]. Gas turbine application in the aviation sector comes in many designs, including Turbojet, Turboshaft, Turboprop, Ramjet, Turbofan or bypass engines. The Turbojet is the most designed engine that resembles that of the basic cycle GT as it was designed to produce power that is just sufficient to power drive the compressor [68,72-74]. In this system, a high-velocity jet is produced by the expelled gas from the turbine which at a high temperature and pressure, expands to the atmospheric pressure in the propelling nozzle [75,76].

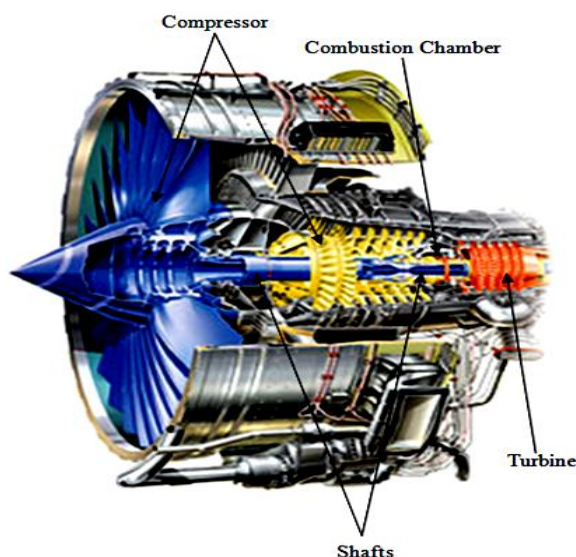

**Fig. 4.** Aircraft propulsion

Gas turbines for industrial application were designed after World War II but introduced to the public in the 1950s [77]. The design of the early heavy-duty GT design was to an extent an extension

of the ST design; there was no consideration for weight and space in these early designs as they were comprised of heavy-wall casings split on horizontal centerlines, large-sized combustors, stators, and large frontal areas, sleeve bearing, as well as thick airfoil sections for blades [53,78]. An industrial plant is meant to serve a service life of approximately 100,000-200,000 h but this is not the case with the aviation GTs where there is a wastage of the kinetic energy of gases expelled from the turbine in a simple cycle due to the absence of a steam generator for heat recovery [79,80]. As depicted in Figure 5, the heavy-duty GT mainly use axial-flow turbines and compressors. Most of the U.S. designs use can-annular combustors while European designs utilize a single-stage side combustor [81]. A fixed or free power turbine is usually used to build GTs for industrial applications since their design is mainly based on the driven load [24,82]. Some are designed to directly drive loads (as in pipeline compressors or alternators) while some are designed to drive loads via gearbox reduction (a requirement for increasing the speed of power turbines) as found in marine propellers [83,84].

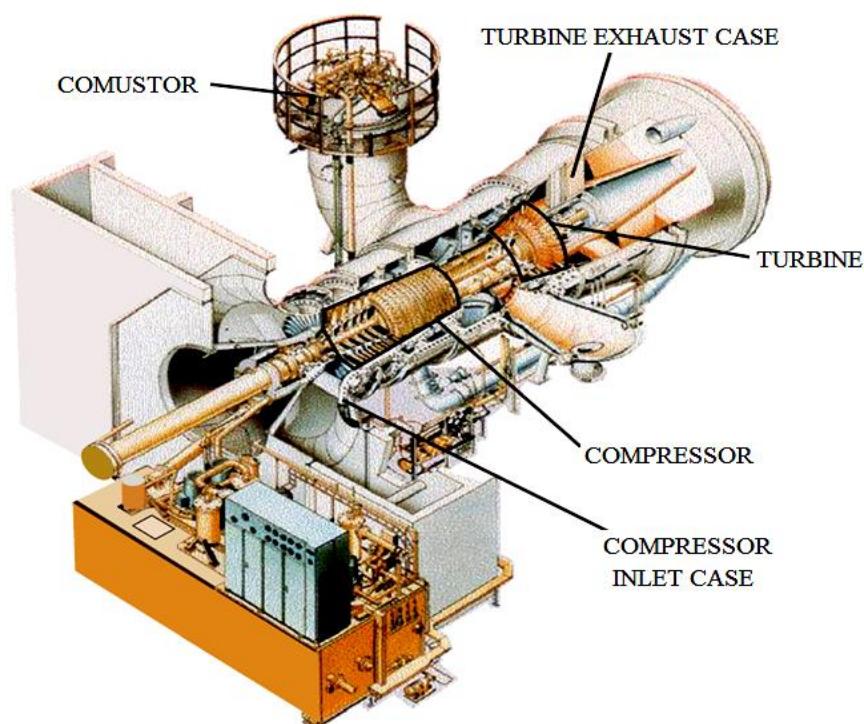

Fig. 5. An industrial-scale GTPP

### 3. Actual Gas Turbine Cycle

In the GT, an actual cycle comprises of the chemical reaction that occurs in the combustion chamber and the combustion processes that terminate in the production of high-temperature gases [85]. These processes are different from the reactants that increase the working fluids' enthalpy [86]. Although the compression processes in the axial flow and centrifugal compressors used in GTs are irreversible, they are adiabatic. A depiction of the expansion process in the GT turbines is presented in Figure 6. As a result of this irreversibility, there is a need to ensure that GTs are designed to increase the required work output to drive the compressor and withstand the mechanical losses in the drive [30, 87, 88].

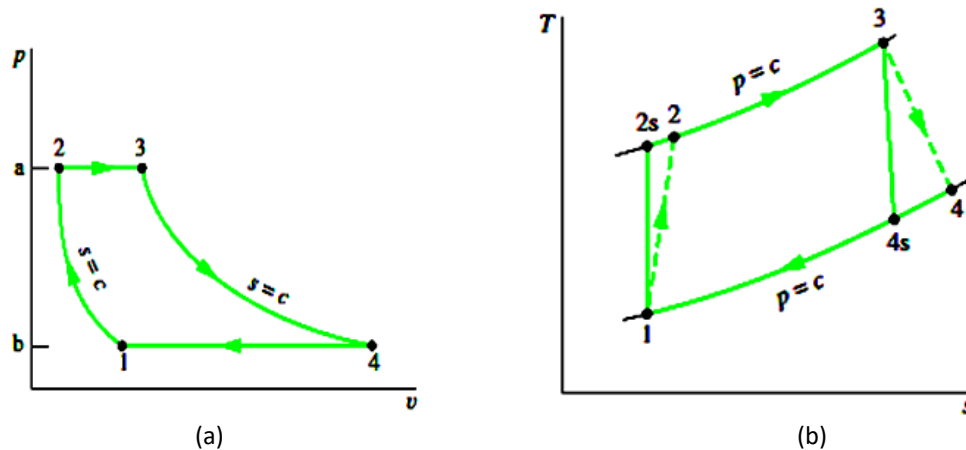

Fig. 6. a)  $p$ - $v$  and b)  $T$ - $s$  diagrams of GTs

#### 4. Gas Turbine Performance

In terms of performance, GT plants built in the 1940s had a simple-cycle efficiency of approximately 17 % as a result of low turbine and compressor isentropic efficiencies and low turbine inlet temperatures [2,89]. The applicability of GT plants was limited despite their versatility and ability to produce energy from different forms of fuel [90-93].

The determination of the performance of GTPPs and their components during the developmental stage has mainly been performed via experiments on the prototypes of the whole GTPP and its major components. However, this approach is not just expensive but time inefficient [94]. Moreover, GTs are meant to usually operate at full load conditions over a significant period of their service life; therefore, there is a need for a detailed study of their cycle performance [32,95]. The most efficient solution for the determination of the performance of a power plant is a mathematical modelling approach using computational techniques [96-99]. To enhance power production, reduce fuel consumption, and boost the performance of power plants, there is a need for continuous studies and in this direction, areas of power leakage in the system can be identified and addressed to achieve the maximum performance efficiency [100,101]. There is a need to develop the tools and equipment that will bring about improvements in the performance of power plants and assist in future design and energy analysis of power plants [102-105]. In this regard, there is a need to mathematically model GTPPs.

The inlet and exit conditions of a GTPP determines its performances in terms of power outputs, thermal efficiency, and fuel consumption [106,107]. The determination of the most important factors (turbine inlet temperature and pressure ratio ) depends on the combination of the values of the ambient conditions and changes associated to pressure loss during the installation [108,109]. The two areas of research and development towards improving the cycle efficiency of GTPP are as follows.

- I. Improvement of the factors that influence the performance of GTs, such as the ambient and operation conditions by
  - Following ISO standards when developing GTs.
  - Improving the compressor pressure ratio and turbine inlet temperatures.
  - Ensuring an increased efficiency of the components of the turbo-machinery.
- II. Modification of the basic GT cycle (e.g. Two-shaft, intercooler, regeneration, and reheated).

#### 4.1 Parametric Influences

Before now, GTs are used for capacity enhancement [110-112] but nowadays, they are used with alterations in power-generation systems and for increased thermal efficiency, especially in the baseload power. The 1930s saw a rapid development of GTs as propulsion devices for jet aircraft but it took until early 1980 for the reliability and efficiency GT plants to progress sufficiently and be widely used in stationary power applications [113]. The size of GTPPs range from 30 - 350 MW [42,55,114].

The performance of GTPPs is influenced by the ambient conditions and these conditions vary with time and place [115]. Both air density, pressure ratio, air mass flow, and power output are greatly reduced in hot days due to low pressure, high temperature, and low air mass flow. These changes significantly affect GTPP performances [116,117]. Therefore, the power output decreases and fuel consumption (SFC) increase when the ambient temperature increases [10,118]. Changes in the flow rate of the air mass entering a GT affects the performance of the whole system, including changes in the air pressure, humidity, and temperature, all of which affects the air density [119-121]. The performance of GTPPs can be decreased in hot days due to the following reasons.

- I. Air density reduction.
- II. Airflow rate reduction.
- III. Pressure ratio n reduction.
- IV. High air temperature, low pressure ratio, and low air mass flow rate which decreases the power output.
- V. Decrease power output which increases specific fuel consumption.
- VI. Decrease in thermal efficiency due to the aforementioned reasons.

Increase in ambient temperatures results in increased temperature and decreased pressure in all stations. The effect of ambient temperature on the performance of GTPPs has been investigated by several studies [106,108,109,122-125]. The monthly ambient temperature changes have been shown to cause a significant reduction in power output from 1.7 to 7.2 %. Similarly, increased ambient temperature has been reported to decrease power generation and increase fuel consumption. A reduction of ambient temperature by about 10 was reported to increase power output by about 0.4 to 7.5 % [120].

The performance of a GTPP is commonly estimated based on its thermal efficiency, specific fuel consumption, work ratio, and power output. However, the performance of a GTPP can be adversely affected by several other parameters like the pressure ratio, combustion inlet temperature, ambient temperature, and turbine inlet temperature [35,126,127]. The effects of ambient temperature, exhaust gas temperature, and ambient pressure on the performance of a GTPP has been studied and reported as depicted in Figure 7 [16]. Evidently, an increase in the ambient temperature caused a decrease in the power output; an increase in the air ambient temperature from 15°C to 30 °C decreased the net power output by about 10 %. This is a typical scenario in the tropical regions with an annual average temperature of about 25 to 35 °C [128,129]. Mostly, the capacity of CCGT power plants is mainly improved by lowering the intake air temperature to about 15°C at a relative humidity of 100 % prior to entering the GTPPs' air compressor [130]. Usually, the efficiency and output power of a GT module is measured by calculating the efficiency operation conditions for the module [131-134]; however, the estimated parameters may sometimes not always be optimal within the gas turbine. Hence, it is important to control the input parameters when aiming to improve the performance of GTPPs [135,136]. Meanwhile, the influence of the pressure ratio, air-fuel ratio, ambient temperature, turbine inlet temperature, compressor isentropic efficiency, and turbine isentropic efficiency on the performance of GTPPs was investigated. Consequently, the management of the operation conditions of a system requires a parametric study on the effect of operation

conditions [13,124]. It is, therefore, necessary to develop a strategy for estimating the performance of GTPPs that considered the influence of operating and ISO conditions [82].

The most significant developments in the thermal efficiency of GTPPs over the last 70 years are due to the efforts made towards increasing the inlet temperature of turbines as driven by the advancement in materials technology and blade cooling technologies [133,137-139]. Such advancements have brought about the use of advanced steam air technologies for metallic turbine blades in large CCGT plant with an overall performance efficiency of 60 % [138,140,141]. Regarding large GTPPs, this advancement has significantly increased the turbine inlet temperatures to about 1800 K but for the small GTPPs, ceramic components must be used due to the geometry of the blade irrespective of the difficulty of its cooling [141]. Another factor that causes an increase in the turbine inlet temperature is the expelled gases from the GT plants [103,142].

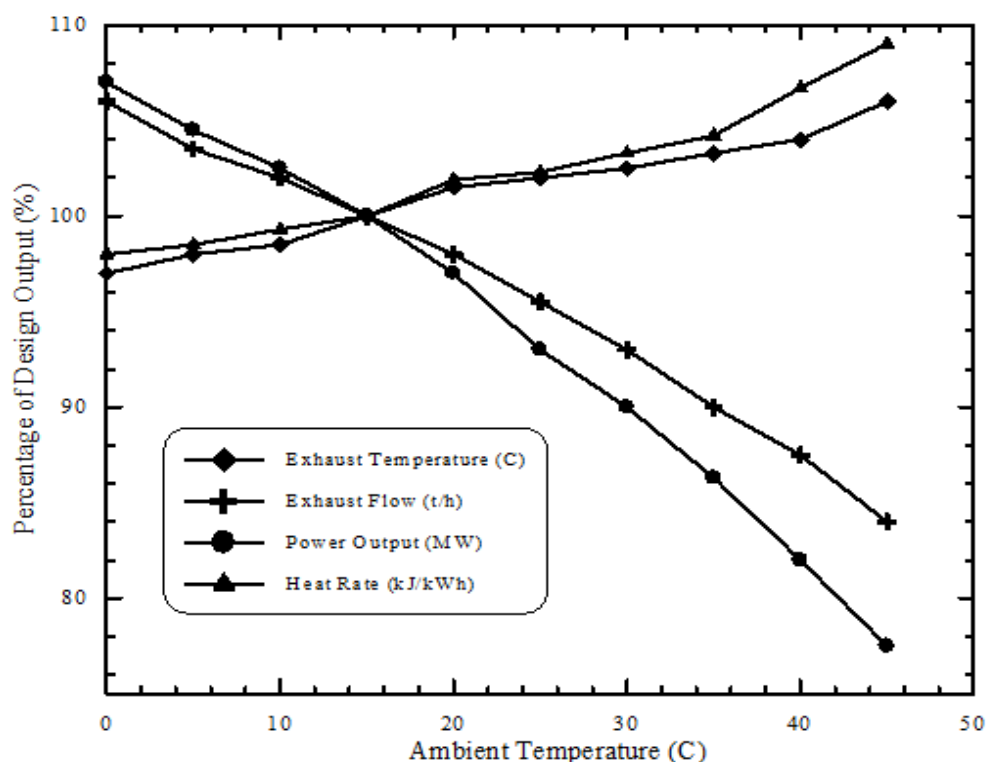

Fig. 7. Ambient temperature effects on the performance of GTs

A parametric study on the effect of various parameters (including turbine inlet temperatures, combustion efficiency, pressure ratio, and isentropic turbine and compressor efficiencies) on GTPPs performance has been carried out by [136]. The values of the performance parameters were calculated based on the basic cycle equations with assumptions of a constant value of the thermodynamic properties. Furthermore, Arrieta and Lora investigated the influence of ambient temperature on CCGT plant performance [119] by considering the ambient temperature effects on the performance of the system at the design stage. Shi and Che [143] suggested a CCGT plant work that utilizes Liquefied Natural Gas as a fuel. The study investigated the effects of the operation parameters on them in a bid to assess the influence of the turbine inlet temperature, pinch point, fuel heating temperature, and condenser pressure on the systems' performance.

A decrease in the condenser pressure at any given turbine inlet temperature will increase the overall thermal efficiency of the system. The reduced fuel consumption associated with the heating of the fuel gas temperature increases the thermal efficiency of GTPPs [144,145]. However, the occurrence of a higher exhaust temperature of an HRSG system at a higher turbine inlet temperature



has been reported [104,146]. A GT system has been thermodynamically studied by Gülen [147] with emphasis on the modelling and analysis of the effect of the pressure ratio, isentropic compressor and turbine efficiency, and turbine inlet temperature on the performance of GTPPs. The performance of the system was measured using the thermal efficiency and power output as performance metrics. The selection of the maximum cycle temperature depended on the strength of the material used in the GTPP at full load and based on ISO recommendations [148].

A thermodynamic model for assessing the performance of an ideal open GT cycle has been proposed by Kurt *et al.*, [149]. This model investigated the influence of several parameters such as the pressure ratio, ambient temperature, and turbine inlet temperature on the systems' performance while the combustion efficiency, low heat values, and isentropic turbine and compressor and turbine efficiencies were kept constant. The performance of the GT was measured based on the cycle fuel consumption, thermal efficiency, and power output [30]. The study observed the optimal power output and thermal efficiency to occur at a high turbine inlet and low ambient temperatures [12,43,56,150].

#### 4.2 Gas Turbine Cycle Modification

Gas turbine power plants are usually built light and compact for performance improvement [92]; however, this is the case for stationary power generation turbines [151,152]. The GTPPs have usually been used as heavy-duty plants for electricity generation and have been presented as better power generation systems [18]. Several strategies that could enhance the performance of GTPPs have been explored by several engineers [153] while different methods for increasing the net power of GTPPs have been used. One of the commonly used methods of enhancing the performance of GTPPs is the intercooler [4,43,154]. This method is mainly used to reduce the air temperature between the compressor stages as depicted in Figure 8. This is aimed at reducing the compressors' power consumption while maintaining a high expelled air pressure from the compressor [155]. The air between the compressor stages can be cooled by the compressor of GTPPs with a high pressure ratio to allow for the combustion of extra fuel and increase power generation using the intercooler [156]. However, the turbine inlet temperature is a limiting factor on the burnt due to the need to provide nozzle and blades on the initial phase of the turbine design using superior materials [157]. This limitation has been addressed by the recent advancements in materials technology.

The use of intercoolers in GTPPs can decrease the power consumption and consequently can increase the thermal efficiency of such systems and the net power output [158,159]. In the low-pressure compressor, air is compressed to intermediate pressure before being passed through the intercooler at a constant pressure to cool. This cooled air heads to a high-pressure compressor where it will be compressed to high pressure and later directed to the combustion chamber and to the expander [160,161]. The intercooler can also be applied in a multistage compression [162,163]. Several studies have presented parametric GT models with intercooler effect, with emphasis on the effects of ambient temperature, pressure ratio, intercooler effectiveness, and peak temperature ratio on the thermal efficiency and power output of such models [2,40,132,156,164,165]. The intercooler effect on GTPPs was analyzed and performances improved based on the first law of thermodynamics. Many studies have shown that for a given pressure ratio, a lower input power is required; however, using intercooler without reheating can decrease the thermal efficiency for at least low pressure ratios [132,157,166]. This decrease is due to the remuneration of the dropped air temperature expelled from the compressor by boosting the inlet temperature of the turbine [138]. The incorporation of an intercooler in a GTPP can reduce the power consumption by the high pressure compressors (HPC), thereby, having a significant influence on the enhancement of the

GTPPs' performance [142,161,167]. As the temperature of the air entering the HPC is decreased, the air mass flow rate will be increased, thereby, boosting the power output. The low temperature discharged from the compressor carries enough air to cool the GT blades [158,168].

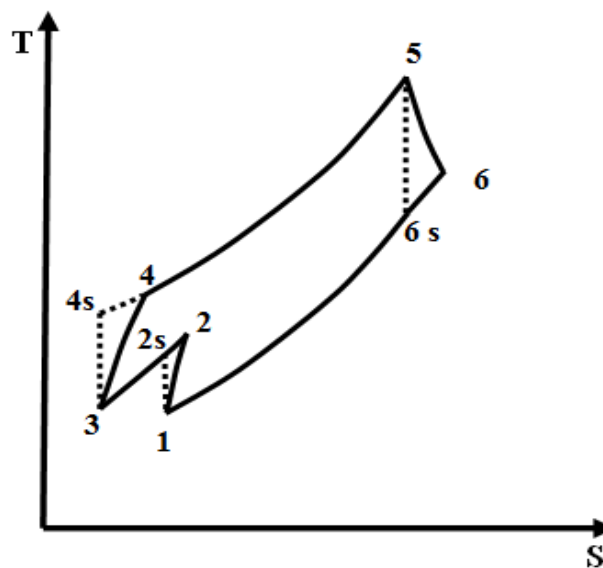

Fig. 8. T-S diagram for GT with an intercooler

The GTs manufactured by GE in the early 1990s generated a net power of 135.7 MW, with a pressure ratio of 13.5, and a thermal efficiency of 33 % in a simple GT operation cycle [1]. These GTs produced up to 282 MW using a turbine inlet temperature of 1425 °C at a thermal efficiency of 39.5 % in the simple GT operation cycle [17,129,169]. The GT plants increasingly becoming the ideal option for future power plants due to their reduced electricity cost, efficient fuel conversion, low installation and maintenance costs, and their ability to utilize a wide range of hydrocarbons as fuel [61,90,170]. They emit gases with relatively fewer pollutants and can be used to preheat air before entering into the combustion chamber; it can also be used for district heating as in combined power and heat plants [171-174]. The performance of a GT can be evaluated in terms of its power output, efficiency, specific fuel consumption, and the work ratio; however, several parameters such as the combustion inlet temperature and the inlet turbine temperature can affect this performance [56,58,175]. Obviously, GT manufacturers have improved on these parameters in recent times [149,176,177]. Meanwhile, the performance of GT plants can also be affected by the operating parameters like the altitude, humidity, ambient temperature, inlet, and exhaust losses. Normally, GTs draw air directly from the environment and as such, factors that affect air density or air mass flow rate into the compressor will affect its performance [108,109].

The exhaust gas expelled from the GT turbine is usually at a high temperature of about 500°C while air exiting the compressor is at a lower temperature of about 300°C [110,114,178]. Hence, the hot exhaust gas serves as a medium of heat transfer to the air that is leaving the compressor through a heat exchanger in a process known as recuperation or regeneration [179,180]. The Gt regenerators are typically tube and shell heat exchangers which are designed as tubes of small diameters. The air within these tubes is at high pressure while the exhaust gas is at a lower pressure in multiple passes outside the tubes [32,152,181]. The use of a regenerative heat exchanger in the cycle improved the thermal efficiency of the GT due to the regeneration of a portion of the heat lost to the environment in the exhaust gases and its subsequent use to preheat the air that is entering the combustion chamber [132,182]. Consequently, this process reduces the fuel consumption below the level required to generate the same power output in the GT [97,183,184]. It is, however, recommended

to use regenerators when the exiting air temperature from the compressor is less than the exhaust gas temperature exiting the turbine [185-187]; otherwise, there will be a reverse in the heat flow direction which will cause a decrease in the efficiency of the system. This condition must be met to achieve a GT that operates at a high-pressure ratio [106,188-191].

Fuel consumption is reduced when the efficiency of the regenerator is high because the air entering the combustion chamber will be preheated to a higher temperature as depicted in shown Figure 9 [57]. However, such a high level of effectiveness can only be achieved with larger regenerators and such regenerators come at a higher cost and could cause a drop in the pressure because of the decrease in the shaft power. Due to the significant effect of pressure drop on the effectiveness of regenerators, it must be kept low on both sides [152,181]. The pressure drop of the air on the high-pressure side is usually maintained at < 2% of the overall discharged pressure from the compressor [179,192]. The effectiveness of most regenerators in practice is < 85 % [193]. Under the influence of a regenerator, the performance of an ideal Brayton cycle is dependent on the pressure ratio and on the maximum to minimum temperature ratio [57,179,194,195]. Mostly, regeneration is most effective at high maximum to minimum temperature ratios and lower pressure ratios of the GT cycle [195,196].

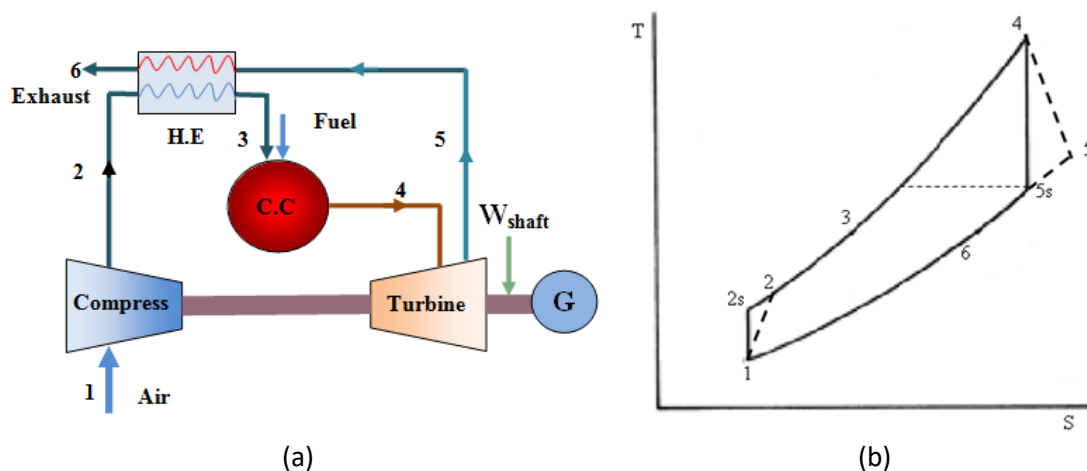

**Fig. 9.** (a) Schematic and (b) T-S diagram of regenerative GT cycle

An alternative regenerative GT approach has been proposed due to the growth of the regenerative GTPPs [47,197]. A comparison of the temperature-entropy plots of the regenerative GTPP and the proposed alternative regenerative GTPP is depicted in Figure 10. Facchini [198] suggested and analyzed the performance of an alternative regenerative GTPP while Facchini and Sguanci [199] performed an off-design performance evaluation of the alternative regenerative GTPP. The evaluations showed the proposed alternative regenerative GTPP to be possible even at high pressure ratios and thus, making it possible to convert high pressure ratio regenerative GTPPs into the GT cycle for thermal efficiency improvement. The design performance of a GT cycle has been analyzed by Cardu and Baica and based on the analysis, the alternative regenerative GT cycle was concluded to be superior to the regenerative GT cycle [200].

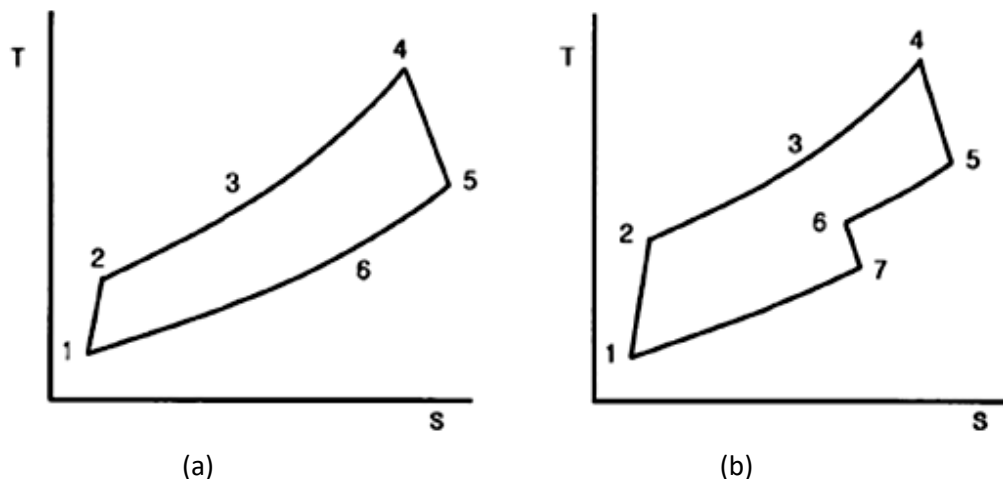

**Fig. 10.** Temperature-entropy diagrams of regenerative and alternative regenerative cycles (a) Regenerative gas turbine (b) Alternative regenerative gas turbine

The same cycle was also suggested by Dellenback [179] who conducted a performance and parametric analyses of the system. The analyses showed the pressure ratio of the alternative regenerative GT cycle to be higher compared to that of the regenerative GT cycle with a high maximum thermal efficiency. The results are, however, still unreliable since the model was based on constant properties. The obtained regenerative thermal efficiency was 50 % at the optimum pressure ratio of 22 while for a simple GT working at the same temperatures, the thermal efficiency will only be 43.8 % at an optimal pressure ratio of 50 [132,179]. Elmegaard and Qvale [201] analyzed an alternative regenerative GT cycle based on variable properties and posited that it is advantageous when there is a limited range of design parameters.

The last 3 decades have witnessed great development in the role of GTPP in electric energy generation. The flexible cycles of Gt due to performance parameters can be enhanced through the addition of new components to the simple GT cycle. Several methods have been developed for the enhancement of the performance of GT cycles [151]; thus, several studies have been conducted on advanced GT cycles, such as those on the humid air, turbine regenerative cycle, and the steam injected GT cycle [198,202,203]. The primary aim of most of these investigations is mainly to achieve higher thermal efficiency in GT cycles [166]. However, this performance improvement can be achieved through the use of an additional combustion chamber (reheat) in the GT cycle [2,7,57]. There are two processes in the expansion process within the reheat GT. An additional combustion chamber is positioned between the low-pressure and high-pressure turbines. In the GT cycle, the combustion process takes place at a higher air-fuel ratio [2,97,168]; therefore, the gases exiting the high-pressure turbine is saturated with oxygen. This gas enters the reheat combustion chamber to stimulate a supplementary combustion process that will increase the gas temperature. From the reviewed studies on reheat GT cycles, the reheating combustion chamber has been shown to increase the network and decrease the thermal efficiency compared to a simple GT cycle [204]. However, the maximum network is obtained in the reheat GT when there is an equal pressure ratio between the low and high-pressure turbines [86,133,164]. Da Cunha Alves *et al.*, [205], they presented A model for evaluation of the GT performance with effect of reheat and intercooler.

A comprehensive design method to obtain improved performance of GTPP has been presented in many studies [166,201,205-208]. Furthermore, a study on the influence of regenerated, intercooled, and reheated on a range of existing GTs has been presented in Figure 11 [34,209]. The proposed design steps have been applied on the 3 existing GT with varying design complexities while a comparison of the performance of GTs with these modifications has been presented. Furthermore,

a stage-wise analysis of the turbine and compressor sections of the modified GT was conducted [47,210]. The analyses showed all the modified GT plants to exhibit higher performances, with an increase in the cycle efficiency from 9% to 26% compared to their original values [88,211]. A computational thermodynamic analysis method has been used to study the effects of the relative humidity, turbine inlet temperature, and pressure ratio on the performance of complex GT cycles. The studied complex GT cycle consisted of the indirect intercooled reheat regenerative GT with inlet air influenced by the indirect evaporative cooling and air evaporative aftercooling of the compressor discharge [196,207,209]. There was a significant variation in the effects of the power output and thermal efficiency compared to those of the pressure ratio, relative humidity, and turbine inlet temperature [122,177].

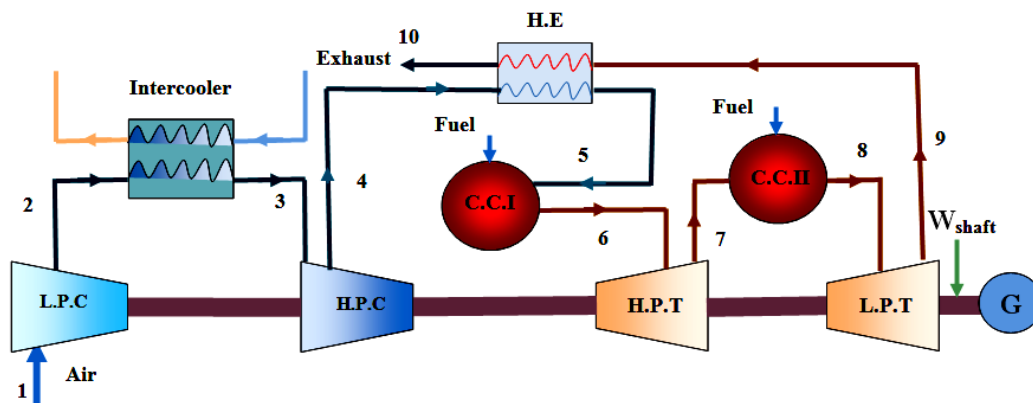

Fig. 11. A schematic representation of regenerative, intercooler, and reheat GTPP

Bassily [132] presented 6 different GT configurations with intercooled, reheat, and regenerative before proposing a parametric analysis for the influence of the turbine inlet temperature, the ambient temperature, and relative humidity on the systems' performance. From the results, the optimal pressure ratio was found to increase by about 1.5 after increasing the turbine inlet temperature (100 K). A simulation model for the study of the influence of the ambient temperature, the turbine inlet temperature, the ambient relative humidity, the pressure ratio, and the effectiveness of the regenerated heat exchanger on the performance of all configurations have been introduced by Bassily [165]. The study showed an increase in the regenerative heat exchanger capacity after increasing the turbine inlet temperature. This capacity increase translated into an increased effectiveness of the regenerated heat exchanger and a gain in the GT cycles' thermal efficiency. Ilett and Lawn [212] depended on thermodynamic analysis to derive the optimum efficiencies and work outputs of a simple GT cycle, equivalent CCGT cycles, and several advanced GT cycles. The performance of the advanced cycles with CCGT was improved significantly compared to the simple GT cycle; they were observed to achieve the lowest electricity cost for externally-powered heavy-duty power generation plants.

## 5. Conclusions

The significant progress in the performance of the GT plants research was apparently reviewed. In parallel, several uncertainties were revealed in the applicability of the developed advanced models to evaluate the performance of the power plants based on effective parameters and advanced configurations. These developments were mainly in the strategies used to improve the performance of GTPPs. A summary of the conclusions is as follows.

- I. A decrease in the pressure ratio decreases the heat duty in both simple and complex cycles of GT plants but was increased with reduced ambient temperature and increased TIT (translates to enhanced thermal efficiency).
- II. The efficiency of GTPPs is strongly affected by the pressure ratio  $s$ , the air-fuel ratio, the ambient temperature, and the isentropic efficiencies.
- III. Most of the proposed models are obviously dependent on fixed-up cycles or performance analysis some have considered variable plant modeling configurations and have been based on energy analysis approach.
- IV. Optimization techniques have been used to investigate the maximum technical parameters that could maximize the performance of power plants.

The literature review demonstrates that the ongoing power plant optimization research looks for peak performance. The employment of the optimization techniques has shown robustness, suitability for parallel computing, and efficiency; therefore, it does not require modification for a specific problem. The qualitative and quantitative identifications are a necessity for the vital effective parameters that requires to be included in the development of the performance of GT power plants.

### Acknowledgements

The authors would like to thank Tikrit University for providing laboratory facilities and financial support.

### References

- [1] E. Jeffs, *Generating power at high efficiency: Combined cycle technology for sustainable energy production*, Elsevier, 2008.
- [2] A. Razak, *Industrial gas turbines: performance and operability*, Elsevier, 2007.
- [3] Olumayegun, Olumide, Meihong Wang, and Greg Kelsall. "Closed-cycle gas turbine for power generation: A state-of-the-art review." *Fuel* 180 (2016): 694-717.
- [4] Alkilaibi, A. M., M. N. Khan, and W. A. Khan. "Thermodynamic analysis of gas turbine with air bottoming cycle." *Energy* 107 (2016): 603-611.
- [5] Bartnik, Ryszard, and Zbigniew Buryn. *Conversion of coal-fired power plants to cogeneration and combined-cycle: thermal and economic effectiveness*. Springer Science & Business Media, 2011.
- [6] Dincer, Ibrahim, Marc A. Rosen, and Calin Zamfirescu. "Exergetic performance analysis of a gas turbine cycle integrated with solid oxide fuel cells." *Journal of Energy Resources Technology* 131, no. 3 (2009): 032001.
- [7] Nakamura, Hiromi, Takehiko Takahashi, Norio Narazaki, Kazuo Yamamoto, and Norio Sayama. "Regenerative gas turbine cycle." U.S. Patent 4,653,268, issued March 31, 1987.
- [8] Ibrahim, Thamir K., Firdaus Basrawi, Omar I. Awad, Ahmed N. Abdullah, G. Najafi, Rizlman Mamat, and F. Y. Hagos. "Thermal performance of gas turbine power plant based on exergy analysis." *Applied thermal engineering* 115 (2017): 977-985.
- [9] Awad, Omar I., Rizalman Mamat, Thamir K. Ibrahim, Maurice Kettner, K. Kadirgama, A. M. Leman, and A. I. M. Saiful. "Effects of fusel oil water content reduction on fuel properties, performance and emissions of SI engine fueled with gasoline-fusel oil blends." *Renewable energy* 118 (2018): 858-869.
- [10] Ibrahim, Thamir K., M. M. Rahman, and Ahmed N. Abdalla. "Improvement of gas turbine performance based on inlet air cooling systems: A technical review." *International journal of physical sciences* 6, no. 4 (2011): 620-627.
- [11] Rahman, M. M., Thamir K. Ibrahim, and Ahmed N. Abdalla. "Thermodynamic performance analysis of gas-turbine power-plant." *International Journal of Physical Sciences* 6, no. 14 (2011): 3539-3550.
- [12] Ibrahim, Thamir K., M. M. Rahman, and Ahmed N. Abdalla. "Gas turbine configuration for improving the performance of combined cycle power plant." *Procedia Engineering* 15 (2011): 4216-4223.
- [13] Rahman, M. M., Thamir K. Ibrahim, K. Kadirgama, R. Mamat, and Rosli A. Bakar. "Influence of operation conditions and ambient temperature on performance of gas turbine power plant." In *Advanced Materials Research*, vol. 189, pp. 3007-3013. Trans Tech Publications, 2011.
- [14] Aker, G. F., and H. I. H. Saravanamuttoo. "Predicting gas turbine performance degradation due to compressor fouling using computer simulation techniques." *Journal of engineering for gas turbines and power* 111, no. 2 (1989): 343-350.

- [15] Ragland, T. L. "Industrial gas turbine performance uprates: Tips, tricks, and traps." *Journal of engineering for gas turbines and power* 120, no. 4 (1998): 727-734.
- [16] Taniguchi, Hiroshi, Sigehiro Miyamae, Norio Arai, and Noam Lior. "Power generation analysis for high-temperature gas turbine in thermodynamic process." *Journal of Propulsion and Power* 16, no. 4 (2000): 557-561.
- [17] Allouis, C., A. Amoresano, G. Langella, V. Niola, and G. Quaremba. "Characterization of gas turbine burner instabilities by wavelet analysis of infrared images." *Experimental Thermal and Fluid Science* 73 (2016): 94-100.
- [18] Balevic, David, Steven Hartman, and Ross Youmans. "Heavy-duty gas turbine operating and maintenance considerations." *GE Energy, Atlanta, GA* (2010).
- [19] Ibrahim, Thamir K., Mohammed K. Mohammed, Omar I. Awad, Rizalman Mamat, and M. Kh Abdolbaqi. "Thermal and Economic Analysis of Gas Turbine Using Inlet Air Cooling System." In *MATEC Web of Conferences*, vol. 225, p. 01020. EDP Sciences, 2018.
- [20] Awad, Omar I., Rizalman Mamat, M. M. Noor, Thamir K. Ibrahim, I. M. Yusri, and A. F. Yusop. "The impacts of compression ratio on the performance and emissions of ice powered by oxygenated fuels: A review." *Journal of the Energy Institute* 91, no. 1 (2018): 19-32.
- [21] Awad, Omar I., R. Mamat, Thamir K. Ibrahim, Ftwi Y. Hagos, M. M. Noor, I. M. Yusri, and A. M. Leman. "Calorific value enhancement of fusel oil by moisture removal and its effect on the performance and combustion of a spark ignition engine." *Energy conversion and management* 137 (2017): 86-96.
- [22] Sullerey, R. K., and Ankur Agarwal. "Performance improvement of gas turbine cycles." *International Journal of Turbo and Jet Engines* 25, no. 3 (2008): 209-220.
- [23] Bade, Mukund H., and Santanu Bandyopadhyay. "Analysis of gas turbine integrated cogeneration plant: Process integration approach." *Applied Thermal Engineering* 78 (2015): 118-128.
- [24] Boyce, Meherwan P. *Gas turbine engineering handbook*. Elsevier, 2011.
- [25] Liu, Mingxi, Yang Shi, and Fang Fang. "Combined cooling, heating and power systems: A survey." *Renewable and Sustainable Energy Reviews* 35 (2014): 1-22.
- [26] Basrawi, Firdaus, Thamir K. Ibrahim, Khairul Habib, and Takanobu Yamada. "Effect of operation strategies on the economic and environmental performance of a micro gas turbine trigeneration system in a tropical region." *Energy* 97 (2016): 262-272.
- [27] Basrawi, Firdaus, Izwan Ismail, Thamir Khalil Ibrahim, Daing Mohamad Nafiz Daing Idris, and Shahrani Anuar. "A study on the power generation potential of mini wind turbine in east coast of Peninsular Malaysia." In *AIP Conference Proceedings*, vol. 1826, no. 1, p. 020023. AIP Publishing, 2017.
- [28] Fischer, Willibald J., Wolfgang Winter, and Joergen Kroemeke. "SCC5-8000H 1S."
- [29] Mohammed, Mohammed Kamil, Omar I. Awad, M. M. Rahman, G. Najafi, Firdaus Basrawi, Ahmed N. Abd Alla, and Rizalman Mamat. "The optimum performance of the combined cycle power plant: A comprehensive review." *Renewable and Sustainable Energy Reviews* 79 (2017): 459-474.
- [30] De Sa, Ashley, and Sarim Al Zubaidy. "Gas turbine performance at varying ambient temperature." *Applied Thermal Engineering* 31, no. 14-15 (2011): 2735-2739.
- [31] Kim, Kyoung Hoon, Hyung-Jong Ko, and Horacio Perez-Blanco. "Analytical modeling of wet compression of gas turbine systems." *Applied Thermal Engineering* 31, no. 5 (2011): 834-840.
- [32] Kim, Tong Seop, and Sung Hoon Hwang. "Part load performance analysis of recuperated gas turbines considering engine configuration and operation strategy." *Energy* 31, no. 2-3 (2006): 260-277.
- [33] Moran, Michael J., Howard N. Shapiro, Daisie D. Boettner, and Margaret B. Bailey. *Fundamentals of engineering thermodynamics*. John Wiley & Sons, 2010.
- [34] Ibrahim, Thamir K., and M. M. Rahman. "Effects of isentropic efficiency and enhancing strategies on gas turbine performance." *Journal of Mechanical Engineering and Sciences* 4 (2013): 383-96.
- [35] Ibrahim, Thamir K., M. M. Rahman, Obed M. Ali, Firdaus Basrawi, and Rizalman Mamat. "Optimum performance enhancing strategies of the gas turbine based on the effective temperatures." In *MATEC Web of Conferences*, vol. 38, p. 01002. EDP Sciences, 2016.
- [36] Wu, Chih. *Thermodynamics and heat powered cycles: a cognitive engineering approach*. Nova Publishers, 2007.
- [37] Boles, M., and Y. Cengel. "An Engineering Approach." *New York: McGraw-Hill Education* (2014).
- [38] Basrawi, Firdaus, Thamir K. Ibrahim, Surendran S. Sathiyaseelan, and A. A. Razak. "Experimental Investigation on Performance of Solar-Powered Attic Ventilation." In *Sustainable Thermal Power Resources Through Future Engineering*, pp. 1-19. Springer, Singapore, 2019.
- [39] J.H. Horlock, D.T. Watson, T.V. Jones. "Limitations on Gas Turbine Performance Imposed by Large Turbine Cooling Flows." *Journal of Engineering for Gas Turbines and Power* 123, no. 3 (2001): 487-494.
- [40] Horlock, John H. *Advanced gas turbine cycles: a brief review of power generation thermodynamics*. Elsevier, 2013.
- [41] Zhang, Na, and Ruixian Cai. "Analytical solutions and typical characteristics of part-load performances of single shaft gas turbine and its cogeneration." *Energy Conversion and Management* 43, no. 9-12 (2002): 1323-1337.

- [42] Ibrahim, Thamir K. "The Life cycle assessments of gas turbine using inlet air cooling system." *Tikrit Journal of Engineering Sciences* 22, no. 1 (2015): 69-75.
- [43] Ibrahim, Thamir K., and M. M. Rahman. "Optimum performance improvements of the combined cycle based on an intercooler–reheated gas turbine." *Journal of Energy Resources Technology* 137, no. 6 (2015): 061601.
- [44] Najjar, Yousef SH. "Enhancement of performance of gas turbine engines by inlet air cooling and cogeneration system." *Applied Thermal Engineering* 16, no. 2 (1996): 163-173.
- [45] Najjar, Yousef SH. "Efficient use of energy by utilizing gas turbine combined systems." *Applied Thermal Engineering* 21, no. 4 (2001): 407-438.
- [46] Kim, J. H., T. S. Kim, J. L. Sohn, and S. T. Ro. "Comparative analysis of off-design performance characteristics of single and two shaft industrial gas turbines." In *ASME Turbo Expo 2002: Power for Land, Sea, and Air*, pp. 509-516. American Society of Mechanical Engineers, 2002.
- [47] Kim, Kyoung Hoon, and Horacio Perez-Blanco. "Potential of regenerative gas-turbine systems with high fogging compression." *Applied Energy* 84, no. 1 (2007): 16-28.
- [48] Kim, T. S., and S. T. Ro. "Power augmentation of combined cycle power plants using cold energy of liquefied natural gas." *Energy* 25, no. 9 (2000): 841-856.
- [49] Najjar, Yousef SH, Abdullah S. Alghamdi, and Mohammad H. Al-Beirutty. "Comparative performance of combined gas turbine systems under three different blade cooling schemes." *Applied Thermal Engineering* 24, no. 13 (2004): 1919-1934.
- [50] Haglind, Fredrik. "Variable geometry gas turbines for improving the part-load performance of marine combined cycles–gas turbine performance." *Energy* 35, no. 2 (2010): 562-570.
- [51] F Haglind, Fredrik. "Variable geometry gas turbines for improving the part-load performance of marine combined cycles–Combined cycle performance." *Applied Thermal Engineering* 31, no. 4 (2011): 467-476.
- [52] Al-Sammarraie, Ahmed Tawfeeq Ahmed, Raaid Rashad Jassem, and Thamir K. Ibrahim. "Mixed convection heat transfer in inclined tubes with constant heat flux." *European Journal of Scientific Research* 97, no. 1 (2013): 144-158.
- [53] Zaidan, Maki H., Aadel AR Alkumait, and Thamir K. Ibrahim. "Assessment of heat transfer and fluid flow characteristics within finned flat tube." *Case studies in thermal engineering* 12 (2018): 557-562.
- [54] Mhamuad, Aziz7 M., Thamir Kh Ibrahim, and Raid R. Jasim. "Determination of the temperature distribution the perforated fins under." *Tikrit Journal of Engineering Sciences* 15, no. 2 (2008): 63-78.
- [55] Ibrahim, Thamir K., and Marwah N. Mohammed. "Thermodynamic evaluation of the performance of a combined cycle power plant." *International Journal of Energy Science and Engineering* 1 (2015): 11.
- [56] Ibrahim, Thamir K., and M. M. Rahman. "Parametric simulation of triple-pressure reheat combined cycle: A case study." *Advanced Science Letters* 13, no. 1 (2012): 263-268.
- [57] Rahman, M. M., Thamir K. Ibrahim, M. Y. Taib, M. M. Noor, and Rosli A. Bakar. "Thermal analysis of open-cycle regenerator gas-turbine power-plant." *Fuel* 200, no. 4 (2010): 2.
- [58] Ibrahim, Thamir K., and Mustafizur M. Rahman. "Study on effective parameter of the triple-pressure reheat combined cycle performance." *Thermal Science* 17, no. 2 (2013): 497-508.
- [59] Moran, Michael J., Howard N. Shapiro, Bruce R. Munson, and David P. DeWitt. "Introduction to thermal systems engineering." *Thermodynamics, Fluid Mechanics, and Heat Transfer* (2003).
- [60] Khaljani, M., R. Khoshbakhti Saray, and K. Bahlouli. "Comprehensive analysis of energy, exergy and exergo-economic of cogeneration of heat and power in a combined gas turbine and organic Rankine cycle." *Energy Conversion and Management* 97 (2015): 154-165.
- [61] Aminov, Zarif, Nobukazu Nakagoshi, Tran Dang Xuan, Osamu Higashi, and Khusniddin Alikulov. "Evaluation of the energy efficiency of combined cycle gas turbine. Case study of Tashkent thermal power plant, Uzbekistan." *Applied Thermal Engineering* 103 (2016): 501-509.
- [62] Awad, Omar I., Rizalman Mamat, Thamir K. Ibrahim, Obed M. Ali, K. Kadirgama, and A. M. Leman. "Performance and combustion characteristics of an SI engine fueled with fusel oil-gasoline at different water content." *Applied Thermal Engineering* 123 (2017): 1374-1385.
- [63] Alkumait, Aadel Abdul Razzaq, Maki Haj Zaidan, and Thamir Khalil Ibrahim. "Numerical Investigation of Forced Convection Flow over Backward Facing Step Affected By A Baffle Position." *Journal of Advanced Research in Fluid Mechanics and Thermal Sciences* 52, no. 1 (2018): 33-45.
- [64] A. Zwebek, P. Pilidis. "Degradation Effects on Combined Cycle Power Plant Performance—Part I: Gas Turbine Cycle Component Degradation Effects." *Journal of Engineering for Gas Turbines and Power* 125, no. 3 (2003): 651-657.
- [65] A. Zwebek, P. Pilidis. "Degradation Effects on Combined Cycle Power Plant Performance—Part III: Gas and Steam Turbine Component Degradation Effects." *Journal of Engineering for Gas Turbines and Power* 126, no. 2 (2004): 306-315.



- [66] Zwebek, A., and P. Pilidis. "Degradation Effects on Combined Cycle Power Plant Performance—Part II: Steam Turbine Cycle Component Degradation Effects." *Journal of engineering for gas turbines and power* 125, no. 3 (2003): 658-663.
- [67] Singhal, Subhash C. "Solid oxide fuel cells for stationary, mobile, and military applications." *Solid State Ionics* 152 (2002): 405-410.
- [68] Giampaolo, Tony. *Gas turbine handbook: principles and practice*. Fairmont Press, 2002.
- [69] Binotti, Marco, Paolo De Giorgi, David Sanchez, and Giampaolo Manzolini. "Comparison of different strategies for heliostats aiming point in cavity and external tower receivers." *Journal of Solar Energy Engineering* 138, no. 2 (2016): 021008.
- [70] El-Sayed, Ahmed F. *Aircraft propulsion and gas turbine engines*. CRC press, 2017.
- [71] Walsh, Philip P., and Paul Fletcher. *Gas turbine performance*. John Wiley & Sons, 2004.
- [72] Ibrahim, Thamir K., Mohammed Kamil Mohammed, Omar I. Awad, Ahmed N. Abdalla, Firdaus Basrawi, Marwah N. Mohammed, G. Najafi, and Rizalman Mamat. "A comprehensive review on the exergy analysis of combined cycle power plants." *Renewable and Sustainable Energy Reviews* 90 (2018): 835-850.
- [73] Salimpour, Mohammad Reza, Amin Ahmadzadeh, and Ahmed T. Al-Sammarraie. "Comparative investigation on the exergoeconomic analysis of solar-driven ejector refrigeration systems." *International Journal of Refrigeration* 99 (2019): 80-93.
- [74] Al-Jethelah, Manar SM, Ahmed Al-Sammarraie, Syeda H. Tasnim, Shohel Mahmud, and Animesh Dutta. "Effect of convection heat transfer on thermal energy storage unit." *Open Physics* 16, no. 1 (2018): 861-867.
- [75] Wilson, David Gordon, and Theodosios Korakianitis. *The design of high-efficiency turbomachinery and gas turbines*. MIT press, 2014.
- [76] Mohammed, Mohammed K., M. Kh Abdolbaqi, Thamir K. Ibrahim, Rizalman Bin Mamat, and Omar I. Awad. "Experimental and Numerical investigation of Heat transfer enhancement using Al<sub>2</sub>O<sub>3</sub>-Ethylene Glycol/Water nanofluids in straight channel." In *MATEC Web of Conferences*, vol. 225, p. 01019. EDP Sciences, 2018.
- [77] Mohajer, A., A. Noroozi, and S. Norouzi. "Optimization of diverter box configuration in a V94. 2 gas turbine exhaust system using numerical simulation." *World Academy of Science, Engineering and Technology* 57 (2009): 566-571.
- [78] Brandt, D. E., and R. R. Wesorick. "GE gas turbine design philosophy." *GER-3434, General Electric* (1994).
- [79] Valdés, Manuel, and José L. Rapún. "Optimization of heat recovery steam generators for combined cycle gas turbine power plants." *Applied Thermal Engineering* 21, no. 11 (2001): 1149-1159.
- [80] Valdes, Manuel, Antonio Rovira, and Ma Dolores Duran. "Influence of the heat recovery steam generator design parameters on the thermoeconomic performances of combined cycle gas turbine power plants." *International Journal of Energy Research* 28, no. 14 (2004): 1243-1254.
- [81] Bilgen, E. "Exergetic and engineering analyses of gas turbine based cogeneration systems." *Energy* 25, no. 12 (2000): 1215-1229.
- [82] Ibrahim, Thamir K., and M. M. Rahman. "Effects of isentropic efficiency and enhancing strategies on gas turbine performance." *Journal of Mechanical Engineering and Sciences* 4 (2013): 383-96.
- [83] Saravanamuttoo, Herbert IH, Gordon Frederick Crichton Rogers, and Henry Cohen. *Gas turbine theory*. Pearson Education, 2001.
- [84] Ibrahim, Thamir K., and M. M. Rahman. "Parametric study of a two-shaft gas turbine cycle model of power plant." In *IOP Conference Series: Materials Science and Engineering*, vol. 36, no. 1, p. 012024. IOP Publishing, 2012.
- [85] Soares, Claire. *Gas turbines: a handbook of air, land and sea applications*. Elsevier, 2011.
- [86] Heppenstall, T. "Advanced gas turbine cycles for power generation: a critical review." *Applied Thermal Engineering* 18, no. 9-10 (1998): 837-846.
- [87] Grange, B., C. Dalet, Q. Falcoz, A. Ferrière, and G. Flamant. "Impact of thermal energy storage integration on the performance of a hybrid solar gas-turbine power plant." *Applied Thermal Engineering* 105 (2016): 266-275.
- [88] Noroozian, Afsaneh, and Mokhtar Bidi. "An applicable method for gas turbine efficiency improvement. Case study: Montazar Ghaem power plant, Iran." *Journal of Natural Gas Science and Engineering* 28 (2016): 95-105.
- [89] Edris, M. "Comparison between single-shaft and mutli-shaft gas fired 800 MWel combined cycle power plant." *Applied Thermal Engineering* 30, no. 16 (2010): 2339-2346.
- [90] Baina, Fabiola, Anders Malmquist, Lucio Alejo, and Torsten H. Fransson. "Effect of the fuel type on the performance of an externally fired micro gas turbine cycle." *Applied Thermal Engineering* 87 (2015): 150-160.
- [91] Harun, Nor Farida, David Tucker, and Thomas A. Adams II. "Impact of fuel composition transients on SOFC performance in gas turbine hybrid systems." *Applied energy* 164 (2016): 446-461.
- [92] Antonanzas, J., E. Jimenez, J. Blanco, and F. Antonanzas-Torres. "Potential solar thermal integration in Spanish combined cycle gas turbines." *Renewable and Sustainable Energy Reviews* 37 (2014): 36-46.
- [93] Antonanzas, J., M. Alia-Martinez, F. J. Martinez-de-Pison, and F. Antonanzas-Torres. "Towards the hybridization of gas-fired power plants: a case study of Algeria." *Renewable and Sustainable Energy Reviews* 51 (2015): 116-124.

- [94] Al-Hamdan, Qusai Z., and Munzer S. Ebaid. "Modeling and simulation of a gas turbine engine for power generation." *Journal of Engineering for Gas Turbines and Power* 128, no. 2 (2006): 302-311.
- [95] Al-Doori, Wadhah Hussein Abdul Razzaq. "Influence of Steam Injection on the Performance of Combined Cycle Power Plant." *Journal of Engineering and Applied Sciences* 6, no. 6 (2011): 390-396.
- [96] Barsali, Stefano, A. De Marco, Romano Giglioli, Giulia Ludovici, and A. Possenti. "Dynamic modelling of biomass power plant using micro gas turbine." *Renewable Energy* 80 (2015): 806-818.
- [97] Barsali, Stefano, A. De Marco, Romano Giglioli, Giulia Ludovici, and A. Possenti. "Dynamic modelling of biomass power plant using micro gas turbine." *Renewable Energy* 80 (2015): 806-818.
- [98] Balamurugan, S., N. Janarthanan, and KRM Vijaya Chandrakala. "Small and large signal modeling of heavy duty gas turbine plant for load frequency control." *International Journal of Electrical Power & Energy Systems* 79 (2016): 84-88.
- [99] Tiwari, A. K., Mohd Islam, M. M. Hasan, and M. N. Khan. "Thermodynamic simulation of performance of combined cycle with variation of cycle peak temperature & specific heat ratio of working fluid." *International Journal of Engineering Studies* 2, no. 3 (2010): 307-316.
- [100] Poullikkas, Andreas. "An overview of current and future sustainable gas turbine technologies." *Renewable and Sustainable Energy Reviews* 9, no. 5 (2005): 409-443.
- [101] Basrawi, Firdaus, A. I. M. Al-Anati, Thamir K. Ibrahim, Mohd Hazwan Yusof, A. A. Razak, Shaharin Anuar Sulaiman, and Takanobu Yamada. "Theoretical Analysis on the Micro Gas Turbine Integrated Solar Farm for Power Output Stabilization." In *MATEC Web of Conferences*, vol. 225, p. 04012. EDP Sciences, 2018.
- [102] Barzegar Avval, H., P. Ahmadi, A. R. Ghaffarizadeh, and M. H. Saidi. "Thermo-economic-environmental multiobjective optimization of a gas turbine power plant with preheater using evolutionary algorithm." *International Journal of Energy Research* 35, no. 5 (2011): 389-403.
- [103] Ahmadi, Pouria, Ibrahim Dincer, and Marc A. Rosen. "Exergy, exergoeconomic and environmental analyses and evolutionary algorithm based multi-objective optimization of combined cycle power plants." *Energy* 36, no. 10 (2011): 5886-5898.
- [104] Ehyaei, Mehdi A., Mojtaba Tahani, Pouria Ahmadi, and Mohammad Esfandiari. "Optimization of fog inlet air cooling system for combined cycle power plants using genetic algorithm." *Applied Thermal Engineering* 76 (2015): 449-461.
- [105] Al-Taha, Wadhah H., and Hassan A. Osman. "Performance Analysis of a Steam Power Plant: A Case Study." In *MATEC Web of Conferences*, vol. 225, p. 05023. EDP Sciences, 2018.
- [106] Farshi, L. Garooci, SM Seyed Mahmoudi, and A. H. Mosafa. "Improvement of simple and regenerative gas turbine using simple and ejector-absorption refrigeration." *IUST International Journal of Engineering Science* 19, no. 5-1 (2008): 127-136.
- [107] Khaliq, Abdul, and Ibrahim Dincer. "Energetic and exergetic performance analyses of a combined heat and power plant with absorption inlet cooling and evaporative aftercooling." *Energy* 36, no. 5 (2011): 2662-2670.
- [108] Farzaneh-Gord, Mahmood, and Mahdi Deymi-Dashtebayaz. "A new approach for enhancing performance of a gas turbine (case study: Khangiran refinery)." *Applied Energy* 86, no. 12 (2009): 2750-2759.
- [109] Farzaneh-Gord, Mahmood, and Mahdi Deymi-Dashtebayaz. "Effect of various inlet air cooling methods on gas turbine performance." *Energy* 36, no. 2 (2011): 1196-1205.
- [110] Basrawi, Firdaus, Thamir K. Ibrahim, Giok Chui Lee, Khairul Habib, and Hassan Ibrahim. "Effect of solar fraction on the economic and environmental performance of solar air-conditioning by adsorption chiller in a tropical region." *Journal of Solar Energy Engineering* 137, no. 6 (2015): 061009.
- [111] Ibrahim, Thamir K., and M. M. Rahman. "Effects of cycle peak temperature ratio on the performance of combined cycle power plant." *International Journal of Automotive & Mechanical Engineering* 13, no. 2 (2016).
- [112] Ibrahim, Thamir K., and M. M. Rahman. "Thermal impact of operating conditions on the performance of a combined cycle gas turbine." *Journal of applied research and technology* 10, no. 4 (2012): 567-577.
- [113] Eveloy, Valérie, Peter Rodgers, and Linyue Qiu. "Hybrid gas turbine-organic Rankine cycle for seawater desalination by reverse osmosis in a hydrocarbon production facility." *Energy Conversion and Management* 106 (2015): 1134-1148.
- [114] Ibrahim, Thamir K., and M. M. Rahman. "Effect of compression ratio on performance of combined cycle gas turbine." *International journal of energy engineering* 2, no. 1 (2012): 9-14.
- [115] Kakaras, E., A. Doukelis, and S. Karellas. "Compressor intake-air cooling in gas turbine plants." *Energy* 29, no. 12-15 (2004): 2347-2358.
- [116] De Lucia, Maurizio, Carlo Lanfranchi, and Varmi Boggio. "Benefits of compressor inlet air cooling for gas turbine cogeneration plants." *Journal of engineering for gas turbines and power* 118, no. 3 (1996): 598-603.
- [117] Kakaras, E., A. Doukelis, A. Prelipceanu, and S. Karellas. "Inlet air cooling methods for gas turbine based power plants." *Journal of engineering for gas turbines and power* 128, no. 2 (2006): 312-317.

- [118] Alhazmy, M. M., and Yousef SH Najjar. "Augmentation of gas turbine performance using air coolers." *Applied thermal engineering* 24, no. 2-3 (2004): 415-429.
- [119] Arrieta, Felipe R. Ponce, and Electro E. Silva Lora. "Influence of ambient temperature on combined-cycle power-plant performance." *Applied Energy* 80, no. 3 (2005): 261-272.
- [120] Erdem, Hasan Hüseyin, and Süleyman Hakan Sevilgen. "Case study: Effect of ambient temperature on the electricity production and fuel consumption of a simple cycle gas turbine in Turkey." *Applied Thermal Engineering* 26, no. 2-3 (2006): 320-326.
- [121] Zhang, Guoqiang, Jiongzhi Zheng, Yongping Yang, and Wenyi Liu. "Thermodynamic performance simulation and concise formulas for triple-pressure reheat HRSG of gas-steam combined cycle under off-design condition." *Energy conversion and management* 122 (2016): 372-385.
- [122] El Hadik, A. A. "The impact of atmospheric conditions on gas turbine performance." *Journal of Engineering for Gas Turbines and Power* 112, no. 4 (1990): 590-596.
- [123] Ait-Ali, M. A. "Optimum power boosting of gas turbine cycles with compressor inlet air refrigeration." *Journal of engineering for gas turbines and power* 119, no. 1 (1997): 124-130.
- [124] Kolev, N., K. Schaber, and D. Kolev. "A new type of a gas-steam turbine cycle with increased efficiency." *Applied thermal engineering* 21, no. 4 (2001): 391-405.
- [125] Aklilu, B. T., and S. I. Gilani. "Mathematical modeling and simulation of a cogeneration plant." *Applied Thermal Engineering* 30, no. 16 (2010): 2545-2554.
- [126] Basrawi, Firdaus, M. R. R. Chand, K. H. Koo, and Thamir K. Ibrahim. "Theoretical analysis on the economic performance of micro gas turbine-trigeneration system with different operation strategies for residential building in a tropical region." In *MATEC Web of Conferences*, vol. 38, p. 01003. EDP Sciences, 2016.
- [127] Ust, Yasin, Feyyaz Arslan, Ibrahim Ozsari, and Mehmet Cakir. "Thermodynamic performance analysis and optimization of DMC (Dual Miller Cycle) cogeneration system by considering exergetic performance coefficient and total exergy output criteria." *Energy* 90 (2015): 552-559.
- [128] Boonnasa, Somkiat, Pichai Namprakai, and Terachun Muangnapoh. "Performance improvement of the combined cycle power plant by intake air cooling using an absorption chiller." *Energy* 31, no. 12 (2006): 2036-2046.
- [129] Boonnasa, S., and P. Namprakai. "Sensitivity analysis for the capacity improvement of a combined cycle power plant (100-600 MW)." *Applied Thermal Engineering* 28, no. 14-15 (2008): 1865-1874.
- [130] Mohanty, B., and G. Paloso Jr. "Enhancing gas turbine performance by intake air cooling using an absorption chiller." *Heat recovery Systems and CHP* 15, no. 1 (1995): 41-50.
- [131] Bassily, Ashraf M. "Effects of evaporative inlet and aftercooling on the recuperated gas turbine cycle." *Applied thermal engineering* 21, no. 18 (2001): 1875-1890.
- [132] Bassily, A. M. "Performance improvements of the intercooled reheat regenerative gas turbine cycles using indirect evaporative cooling of the inlet air and evaporative cooling of the compressor discharge." *Proceedings of the Institution of Mechanical Engineers, Part A: Journal of Power and Energy* 215, no. 5 (2001): 545-557.
- [133] Bassily, A. M. "Enhancing the efficiency and power of the triple-pressure reheat combined cycle by means of gas reheat, gas recuperation, and reduction of the irreversibility in the heat recovery steam generator." *Applied Energy* 85, no. 12 (2008): 1141-1162.
- [134] Khaliq, A., and S. C. Kaushik. "Thermodynamic performance evaluation of combustion gas turbine cogeneration system with reheat." *Applied Thermal Engineering* 24, no. 13 (2004): 1785-1795.
- [135] Khaliq, Abdul, and Rajesh Kumar. "Thermodynamic performance assessment of gas turbine trigeneration system for combined heat cold and power production." *Journal of Engineering for Gas Turbines and Power* 130, no. 2 (2008): 024501.
- [136] Badran, Omar Othman. "Gas-turbine performance improvements." *Applied Energy* 64, no. 1-4 (1999): 263-273.
- [137] Sanjay, Y., Onkar Singh, and B. N. Prasad. "Energy and exergy analysis of steam cooled reheat gas-steam combined cycle." *Applied Thermal Engineering* 27, no. 17-18 (2007): 2779-2790.
- [138] Sanjay. "Investigation of effect of variation of cycle parameters on thermodynamic performance of gas-steam combined cycle." *Energy* 36, no. 1 (2011): 157-167.
- [139] Bassily, A. M. "Numerical cost optimization and irreversibility analysis of the triple-pressure reheat steam-air cooled GT commercial combined cycle power plants." *Applied Thermal Engineering* 40 (2012): 145-160.
- [140] McDonald, Colin F., and David Gordon Wilson. "The utilization of recuperated and regenerated engine cycles for high-efficiency gas turbines in the 21st century." *Applied Thermal Engineering* 16, no. 8-9 (1996): 635-653.
- [141] McDonald, Colin F., and Colin Rodgers. "Ceramic recuperator and turbine: The key to achieving a 40 percent efficient microturbine." In *ASME Turbo Expo 2005: Power for Land, Sea, and Air*, pp. 963-971. American Society of Mechanical Engineers, 2005.
- [142] Kumari, Anupam. "Investigation of parameters affecting exergy and emission performance of basic and intercooled gas turbine cycles." *Energy* 90 (2015): 525-536.

- [143] Shi, Xiaojun, and Defu Che. "Thermodynamic analysis of an LNG fuelled combined cycle power plant with waste heat recovery and utilization system." *International journal of energy research* 31, no. 10 (2007): 975-998.
- [144] Chuang, Chia-Chin, and Deng-Chern Sue. "Performance effects of combined cycle power plant with variable condenser pressure and loading." *Energy* 30, no. 10 (2005): 1793-1801.
- [145] Basha, Mehaboob, S. M. Shaahid, and Luai Al-Hadhrami. "Impact of fuels on performance and efficiency of gas turbine power plants." *Energy Procedia* 14 (2012): 558-565.
- [146] Nadir, Mahmoud, Adel Ghenaiet, and Carlo Carcasci. "Thermo-economic optimization of heat recovery steam generator for a range of gas turbine exhaust temperatures." *Applied Thermal Engineering* 106 (2016): 811-826.
- [147] Gülen, S. Can. "Second law analysis of integrated solar combined cycle power plants." *Journal of Engineering for Gas Turbines and Power* 137, no. 5 (2015): 051701.
- [148] Ibrahim, Thamir K., and M. M. Rahman. "Effects of operation conditions on performance of a gas turbine power plant." In *National Conference in Mechanical Engineering Research and Postgraduate Studies (2nd NCMER 2010)*, pp. 135-144. 2010.
- [149] Kurt, Hüseyin, Ziyaddin Recebli, and Engin Gedik. "Performance analysis of open cycle gas turbines." *International Journal of Energy Research* 33, no. 3 (2009): 285-294.
- [150] Ibrahim, Thamir K., and M. M. Rahman. "Effects of isentropic efficiencies on the performance of combined cycle power plants." *International Journal of Automotive & Mechanical Engineering* 12 (2015).
- [151] Sheikhbeigi, B., and M. B. Ghofrani. "Thermodynamic and environmental consideration of advanced gas turbine cycles with reheat and recuperator." *International Journal of Environmental Science & Technology* 4, no. 2 (2007): 253-262.
- [152] Sayyaadi, Hoseyn, and Reza Mehrabipour. "Efficiency enhancement of a gas turbine cycle using an optimized tubular recuperative heat exchanger." *Energy* 38, no. 1 (2012): 362-375.
- [153] Bhargava, R. K., M. Bianchi, A. De Pascale, G. Negri Di Montenegro, and A. Peretto. "Gas turbine based power cycles—a state-of-the-art review." In *Challenges of power engineering and environment*, pp. 309-319. Springer, Berlin, Heidelberg, 2007.
- [154] Kaushik, S. C., H. Chandra, and A. Khaliq. "Thermal exergy optimisation for an irreversible cogeneration power plant." *International Journal of Exergy* 2, no. 3 (2005): 260-273.
- [155] Ibrahim, Thamir K., M. M. Rahman, and Ahmed N. Abd Alla. "Study on the effective parameter of gas turbine model with intercooled compression process." *Scientific Research and Essays* 5, no. 23 (2010): 3760-3770.
- [156] Al-Doori, Wadhah Hussein Abdul Razzaq. "Parametric performance of gas turbine power plant with effect intercooler." *Modern Applied Science* 5, no. 3 (2011): 173.
- [157] Canière, Hugo, Arnout Willockx, Erik Dick, and Michel De Paepe. "Raising cycle efficiency by intercooling in air-cooled gas turbines." *Applied Thermal Engineering* 26, no. 16 (2006): 1780-1787.
- [158] Boggia, Stefano, and Klaus Rüd. "Intercooled recuperated gas turbine engine concept." In *41st AIAA/ASME/SAE/ASEE Joint Propulsion Conference & Exhibit*, p. 4192. 2005.
- [159] Cheng, Ching-Yang, and Cha'o-Kuang Chen. "Maximum power of an endoreversible intercooled Brayton cycle." *International Journal of Energy Research* 24, no. 6 (2000): 485-494.
- [160] Yi, Yaofan, Ashok D. Rao, Jacob Brouwer, and G. Scott Samuelsen. "Analysis and optimization of a solid oxide fuel cell and intercooled gas turbine (SOFC-ICGT) hybrid cycle." *Journal of Power Sources* 132, no. 1-2 (2004): 77-85.
- [161] Wang, W. H., L. G. Chen, F. R. Sun, and C. Wu. "Performance optimisation of open cycle intercooled gas turbine power plant with pressure drop irreversibilities." *Journal of the Energy Institute* 81, no. 1 (2008): 31-37.
- [162] Farrell, William M., and Gary L. Leonard. "Intercooled gas turbine engine." U.S. Patent 5,553,448, issued September 10, 1996.
- [163] Horner, Michael W. "Extracted, cooled, compressed/intercooled, cooling/combustion air for a gas turbine engine." U.S. Patent 6,050,080, issued April 18, 2000.
- [164] Abdallah, H., B. Facchini, F. Danes, and J. De Ruyck. "Exergetic optimization of intercooled reheat chemically recuperated gas turbine." *Energy conversion and management* 40, no. 15-16 (1999): 1679-1686.
- [165] Bassily, A. M. "Performance improvements of the intercooled reheat recuperated gas-turbine cycle using absorption inlet-cooling and evaporative after-cooling." *Applied Energy* 77, no. 3 (2004): 249-272.
- [166] Chandra, H., A. Arora, S. C. Kaushik, A. Tripathi, and A. Rai. "Thermodynamic analysis and parametric study of an intercooled-reheat closed-cycle gas turbine on the basis of a new isentropic exponent." *International Journal of Sustainable Energy* 30, no. 2 (2011): 82-97.
- [167] Yadav, R., Sunil Kumar Jumhare, Pradeep Kumar, and Samir Saraswati. "Thermodynamic analysis of intercooled gas-steam combined and steam injected gas turbine power plants." In *ASME Turbo Expo 2004: Power for Land, Sea, and Air*, pp. 731-738. American Society of Mechanical Engineers, 2004.

- [168] Tyagi, S. K., G. M. Chen, Q. Wang, and S. C. Kaushik. "Thermodynamic analysis and parametric study of an irreversible regenerative-intercooled-reheat Brayton cycle." *International Journal of Thermal Sciences* 45, no. 8 (2006): 829-840.
- [169] Awad, Omar I., R. Mamat, Thamir K. Ibrahim, Ali Thaeer Hammid, I. M. Yusri, Mohd Adnin Hamidi, Ali M. Humada, and A. F. Yusop. "Overview of the oxygenated fuels in spark ignition engine: Environmental and performance." *Renewable and Sustainable Energy Reviews* 91 (2018): 394-408.
- [170] Şöhret, Yasin, Selcuk Ekici, Önder Altuntaş, Arif Hepbasli, and T. Hikmet Karakoç. "Exergy as a useful tool for the performance assessment of aircraft gas turbine engines: A key review." *Progress in Aerospace Sciences* 83 (2016): 57-69.
- [171] Wulff, A., and J. Hourmouziadis. "Technology review of aeroengine pollutant emissions." *Aerospace science and technology* 1, no. 8 (1997): 557-572.
- [172] Cano-Andrade, Sergio, Michael R. Von Spakovsky, Alejandro Fuentes, Chiara Lo Prete, and Lamine Mili. "Upper Level of a Sustainability Assessment Framework for Power System Planning." *Journal of Energy Resources Technology* 137, no. 4 (2015): 041601.
- [173] Ozcan, Mustafa. "Estimation of Turkey' s GHG emissions from electricity generation by fuel types." *Renewable and Sustainable Energy Reviews* 53 (2016): 832-840.
- [174] Abdalla, Ahmed N., Omar I. Awad, Hai Tao, Thamir K. Ibrahim, Rizalman Mamat, and Ali Thaeer Hammid. "Performance and emissions of gasoline blended with fusel oil that a potential using as an octane enhancer." *Energy Sources, Part A: Recovery, Utilization, and Environmental Effects* 41, no. 8 (2019): 931-947.
- [175] Ibrahim, Thamir K., and M. M. Rahman. "Effective Parameters on Performance of Multipressure Combined Cycle Power Plants." *Advances in Mechanical Engineering (Hindawi Publishing Corporation)* (2014).
- [176] Tsague, Louis, Thomas Tamié, John Ngundam, and Joseph Tsogo. "Prediction of emissions in turbojet engines exhausts: relationship between nitrogen oxides emission index (EINOx) and the operational parameters." *Aerospace science and technology* 11, no. 6 (2007): 459-463.
- [177] Mohapatra, Alok Ku. "Thermodynamic assessment of impact of inlet air cooling techniques on gas turbine and combined cycle performance." *Energy* 68 (2014): 191-203.
- [178] Ghazikhani, Mohsen, I. Khazaei, and Ehsan Abdekhodaie. "Exergy analysis of gas turbine with air bottoming cycle." *Energy* 72 (2014): 599-607.
- [179] Dellenback, Paul A. "Improved gas turbine efficiency through alternative regenerator configuration." *Journal of Engineering for Gas Turbines and Power* 124, no. 3 (2002): 441-446.
- [180] Benato, Alberto, Anna Stoppato, and Stefano Bracco. "Combined cycle power plants: A comparison between two different dynamic models to evaluate transient behaviour and residual life." *Energy conversion and management* 87 (2014): 1269-1280.
- [181] Dellenback, Paul A. "A reassessment of the alternative regeneration cycle." *Journal of engineering for gas turbines and power* 128, no. 4 (2006): 783-788.
- [182] Hwang, Sung Hoon, Soo Hyoung Yoon, and Tong Seop Kim. "Design and off-design characteristics of the alternative recuperated gas turbine cycle with divided turbine expansion." *Journal of engineering for gas turbines and power* 129, no. 2 (2007): 428-435.
- [183] Rahman, M. M., Thamir K. Ibrahim, M. Y. Taib, M. M. Noor, and Rosli A. Bakar. "Thermal analysis of open-cycle regenerator gas-turbine power-plant, World Academy of Science." *Engineering and Technology Journal* 68, (2010): 6.
- [184] Goodarzi, M. "Comparative energy analysis on a new regenerative Brayton cycle." *Energy Conversion and Management* 120 (2016): 25-31.
- [185] Herraiz, Laura, Dougal Hogg, Jim Cooper, Jon Gibbins, and Mathieu Lucquiaud. "Reducing water usage with rotary regenerative gas/gas heat exchangers in natural gas-fired power plants with post-combustion carbon capture." *Energy* 90 (2015): 1994-2005.
- [186] Tao, Guisheng, Lingen Chen, and Fengrui Sun. "Exergoeconomic performance optimization for an endoreversible regenerative gas turbine closed-cycle cogeneration plant." *Revista mexicana de física* 55, no. 3 (2009): 192-200.
- [187] Bannai, Masaaki, Akira Houkabe, Masahiko Furukawa, Takao Kashiwagi, Atsushi Akisawa, Takuya Yoshida, and Hiroyuki Yamada. "Development of efficiency-enhanced cogeneration system utilizing high-temperature exhaust-gas from a regenerative thermal oxidizer for waste volatile-organic-compound gases." *Applied Energy* 83, no. 9 (2006): 929-942.
- [188] Erbay, L. Berrin, Selahattin Göktun, and Hasbi Yavuz. "Optimal design of the regenerative gas turbine engine with isothermal heat addition." *Applied energy* 68, no. 3 (2001): 249-264.
- [189] Al-Sammarraie, Ahmed T., and Kambiz Vafai. "Heat transfer augmentation through convergence angles in a pipe." *Numerical Heat Transfer, Part A: Applications* 72, no. 3 (2017): 197-214.

- [190] Salimpour, Mohammad Reza, Ahmed T. Al-Sammarraie, Azadeh Forouzandeh, and Mahsa Farzaneh. "Constructal design of circular multilayer microchannel heat sinks." *Journal of Thermal Science and Engineering Applications* 11, no. 1 (2019): 011001.
- [191] Ibrahim, Thamir K., Firdaus Basrawi, Marwah Noori Mohammed, and Hassan Ibrahim. "Effect of perforation area on temperature distribution of the rectangular fins under natural convection." *ARPN Journal of Engineering and Applied Sciences* 11, no. 10 (2016): 6371-6375.
- [192] Bozza, Fabio, Maria Cristina Cameretti, and Raffaele Tuccillo. "Adapting the micro-gas turbine operation to variable thermal and electrical requirements." In *ASME Turbo Expo 2003, collocated with the 2003 International Joint Power Generation Conference*, pp. 741-753. American Society of Mechanical Engineers, 2003.
- [193] Oliveira, Luciana M., Marco AR Nascimento, and Genésio J. Menon. "The thermal impact of using syngas as fuel in the regenerator of regenerative gas turbine engine." In *ASME Turbo Expo 2009: Power for Land, Sea, and Air*, pp. 201-209. American Society of Mechanical Engineers, 2009.
- [194] Kumar, N. Ravi, K. Rama Krishna, and AV Sita Rama Raju. "Performance improvement and exergy analysis of gas turbine power plant with alternative regenerator and intake air cooling." *Energy Engineering* 104, no. 3 (2007): 36-53.
- [195] Kumar, Ravi N., and Rama K. Krishna. "Thermodynamic Analysis of Alternative Regenerator Gas Turbine Configuration based on Exergy." *Journal of the Institution of Engineers(India), Part MC, Mechanical Engineering Division* 87, no. 3 (2006): 47-51.
- [196] A. Kumar, S. Kachhwaha, R. Mishra. "Thermodynamic analysis of a regenerative gas turbine cogeneration plant." *Journal of scientific and Industrial Research* 69, no. 3 (2010): 225-231.
- [197] Chen, Lingen, Fengrui Sun, Chih Wu, and R. L. Kiang. "Theoretical analysis of the performance of a regenerative closed Brayton cycle with internal irreversibilities." *Energy Conversion and Management* 38, no. 9 (1997): 871-877.
- [198] Facchini, Bruno. "New prospects for the use of regeneration in gas turbine cycles." In *the 7 th Congress & Exposition on Gas Turbines in Cogeneration and Utility Industrial and Independent Power Generation, Bournemouth, Engl, 09/21-23/93*, pp. 263-269. 1993.
- [199] Facchini, B., and S. Sguanci. *RE Cycle: A system for good off-design performance*. No. CONF-941024-. American Society of Mechanical Engineers, New York, NY (Unit Cârdu, Mircea, and Malvina Baica. "Gas turbine installations with divided expansion." *Energy conversion and management* 43, no. 13 (2002): 1747-1756.ed States), 1994.
- [200] M. Cârdu, M. Baica, Gas turbine installations with divided expansion, *Energy conversion and management*, 43(13) (2002) 1747-1756.
- [201] Elmegaard, Brian, and Bjofn Qvale. "Regenerative Gas Turbines With Divided Expansion." In *ASME Turbo Expo 2004: Power for Land, Sea, and Air*, pp. 675-682. American Society of Mechanical Engineers, 2004.
- [202] Stecco, Sergio, Umberto Desideri, and N. Bettagli. "Humid air gas turbine cycle: a possible optimization." ASME, 1993.
- [203] De Paepe, Michel, and Erik Dick. "Cycle improvements to steam injected gas turbines." *International journal of energy research* 24, no. 12 (2000): 1081-1107.
- [204] Sarabchi, K. "Performance evaluation of reheat gas turbine cycles." *Proceedings of the Institution of Mechanical Engineers, Part A: Journal of Power and Energy* 218, no. 7 (2004): 529-539.
- [205] da Cunha Alves, M. A., H. F. de Franca Mendes Carneiro, J. R. Barbosa, L. E. Travieso, P. Pilidis, and K. W. Ramsden. "An insight on intercooling and reheat gas turbine cycles." *Proceedings of the Institution of Mechanical Engineers, Part A: Journal of Power and Energy* 215, no. 2 (2001): 163-171.
- [206] Harvey, Simon. "Analysis of a reheat gas turbine cycle with chemical recuperation using Aspen." *Energy conversion and management* 38, no. 15-17 (1997): 1671-1679.
- [207] Khaliq, A., and K. Choudhary. "Thermodynamic performance assessment of an indirect intercooled reheat regenerative gas turbine cycle with inlet air cooling and evaporative aftercooling of the compressor discharge." *International journal of energy research* 30, no. 15 (2006): 1295-1312.
- [208] Marx, Martin. "Investigation and Optimisation of Intercooling in an Intercooled Recuperative Aero Engine." *Master of Science, School of Engineering, Cranfield University, Cranfield* (2007).
- [209] Ibrahim, Thamir K., and M. M. Rahman. "Effect of compression ratio on the performance of different strategies for the gas turbine." *International Journal of Automotive and Mechanical Engineering* 9 (2014): 1747.
- [210] C. Riegler, M. Bauer, J. Kurzke. "Some aspects of modelling compressor behavior in gas turbine performance calculations." *Journal of Turbomachinery* 123, no. 2 (2000): 372-378.
- [211] Tsoutsanis, Elias, Nader Meskin, Mohieddine Benammar, and Khashayar Khorasani. "Transient gas turbine performance diagnostics through nonlinear adaptation of compressor and turbine maps." *Journal of Engineering for Gas Turbines and Power* 137, no. 9 (2015): 091201.

- 
- [212] Ilett, T., and C. J. Lawn. "Thermodynamic and economic analysis of advanced and externally fired gas turbine cycles." *Proceedings of the Institution of Mechanical Engineers, Part A: Journal of Power and Energy* 224, no. 7 (2010): 901-915.