

## Performance Prediction of a Novel Modular Magnetorheological Damper for Seismic Building

Open  
Access

Bhre Wangsa Lenggana<sup>1</sup>, Ubaidillah<sup>1,2,\*</sup>, Fitriani Imaduddin<sup>1,2</sup>, Widyarso<sup>3</sup>, Endra Dwi Purnomo<sup>1</sup>,  
Dewi Utami<sup>1</sup>, Saiful Amri Mazlan<sup>4</sup>

<sup>1</sup> Mechanical Engineering Department, Faculty of Engineering, Universitas Sebelas Maret, 57126 Surakarta, Indonesia

<sup>2</sup> National Center for Sustainable Transportation Technology (NCSTT), Bandung, Indonesia

<sup>3</sup> PT Kayaba Indonesia, MM2100, Cikarang, Indonesia

<sup>4</sup> Advance Vehicle System (AVS), Malaysia Japan International Institute of Technology, Universiti Teknologi Malaysia Kuala Lumpur, Malaysia

### ARTICLE INFO

### ABSTRACT

#### Article history:

Received 11 September 2018

Received in revised form 19 December 2018

Accepted 8 May 2019

Available online 16 June 2019

The new concept of a magnetorheological (MR) damping device used in the seismic building is discussed in this paper. The damper is aimed to deliver a comparable damping performances with the existing semi-active seismic damper design but with lower MR fluids volume requirement. These capability is achieved through the improvement in the MR valve performance using a meandering flow structure which was placed in the bypass line. This research is focused on the performance analysis of the MR valve pressure drop using an analytical approach. There are two main steps needed for the analytical approach, the magnetic field simulation and the analytical pressure drop calculation. The simulation work of the MR valve magnetic circuit performance was carried out using finite element method magnetic (FEMM) software to calculate the distribution of magnetic flux density values. The simulated magnetic field density values would then be matched with the MR fluids characteristics data to predict the yield stress value of the fluids to be used in the pressure drop calculation. As a result, the MR valve is predicted to generate maximum off-state pressure drop of 5.35 MPa and piston speed of 0.184 m/s. Meanwhile, at on-state condition (1.4 A), the valve is generating pressure drop up to 9.13 MPa at piston speed of 0.184 m/s. In summary, with such pressure drop, the seismic damper will be capable to provide comparable damping performance with other seismic MR damper design with only  $1.44 \times 10^{-4} \text{ m}^3$  of MR fluids.

#### Keywords:

Magnetorheological; seismic; valve;  
damper; pressure drop

Copyright © 2019 PENERBIT AKADEMIA BARU - All rights reserved

## 1. Introduction

Indonesia is one of the countries that has a highest risk to earthquake. In the period of 2018-2019 alone, the country has experienced multiple earthquake events that led to major casualties and property loss. It has been reported that among Asia-Pacific countries, Indonesia is the country with second biggest disaster risk in the world [1] due to the fact that the entire country is surrounded by

\* Corresponding author.

E-mail address: [ubaidillah\\_ft@staff.uns.ac.id](mailto:ubaidillah_ft@staff.uns.ac.id) (Ubaidillah)

highlands of volcanoes which prone to cause the earthquakes [2]. Geographically, Indonesia is also located at the confluence of four tectonic plates in the world, namely the continental shelf of Asia and the continent of Australia, and the Indian oceanic plate and the Pacific Ocean which often led to seismic type earthquakes and tsunami [3]. According to the records of The National Disaster Management Agency of Indonesia, there are total incidence of 139 earthquakes event in the period between 2009 to 2018 as shown in Figure 1 [4]. The records from the USGS Geological Survey free catalog throughout Indonesia are also reported that from January 2009 to August 2018 there were 2024 earthquakes hit with magnitudes between 5 to 8 in the Richter Scale. One of the most publicly known disaster from that period is the earthquake event on September 30<sup>th</sup>, 2009, at 5:15 PM in the Mentawai strait with magnitude of 7.9 that caused major property loss and more than 1000 victims.

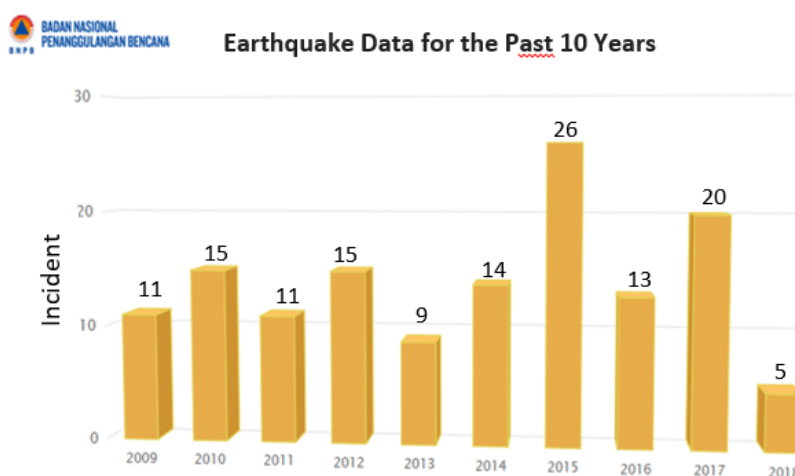

**Fig. 1.** Earthquake data for the past ten years till February 2018 that is recorded by national disaster Management agency of Indonesia; Badan Nasional Penanggulangan Bencana (BNPB) [5]

Earthquakes are a natural event that cannot be avoided and very difficult to be predicted however, the damaging impact can be minimized. The earthquake impacts to property in particular can be mitigated using several devices that allows the building to adapt to seismic activities, such as friction damper, mass damper, viscous damper, PVD damper etc [6]. Among these devices, magnetorheological (MR) damper is one of the advanced solution to reduce the damaging effects of seismic excitations on building a structure. MR damper is a device that capable to vary its damping stiffness via magnetic field. These variable stiffness capabilities are the feature of MR fluids, a unique material that has altered properties to magnetic field stimuli [7]. In the absence of magnetic field, the fluids have a low apparent viscosity but as the magnetic field is induced, the fluid becomes thicker similarly like a paste [8, 9]. The MR fluids replace the role of the hydraulic oil in a viscous damper and allow the damping characteristics to be continuously regulated by the electromagnet [10]. In the case of seismic applications, the damper will be used to allow the building structure to sway during earthquake event and absorb the vibration effect resulting from the earthquake. Structural control methods that supported by the MR damper is more advanced than conventional seismic damping because the damping stiffness can be tuned in real time which made it adaptive to various type of earthquake [4, 11, 12].

Although seismic MR damper is more advanced than conventional seismic damper, the cost of MR fluids is more expensive than the conventional hydraulic oil. Thus, in a seismic damper, that requires abundant volume of fluids to fill the cylinder, the cost of the fluids will be significant to the overall cost of the damper and often hinders the field implementations of the MR damper in civil

structures. In order to promote the installations of MR damper technology, an approach that can solve the challenge of MR damper cost is needed. One of the potential solutions is the development of MR damper designs that have low MR fluid consumption. Therefore, the main objective of this study is to design a seismic damper with a lower consumption of MR fluid by increasing the achievable pressure drop through improvement of MR valve performance. In particular, this study will focus on the analysis of the meandering pattern in improving the MR valve pressure drop achievement.

## 2. Structure of Novel Seismic Damper

The basic structure of the seismic damper used in this study is based in the booster type actuator arrangement. The valve is installed in the center of the damper device as shown in Figure 2. The damper does not use MR fluids completely, but uses oil fluids and MR fluids which are separated by booster. It aims to minimize the use of MR fluids. The valve has annular and radial gaps to channel the flow the MR fluids. The gaps also passed by the magnetic circuit that will let the magnetic fluxes induce the MR fluids and change its viscosity with a magnetic field. In larger point of view, it then affects the damper by augmenting the yield stress of the MR fluid along the fluid resistance gap area, which is also known as the effective area [13]. The yield stress of the MR fluid will increase as the magnetic flux increases and vice versa.

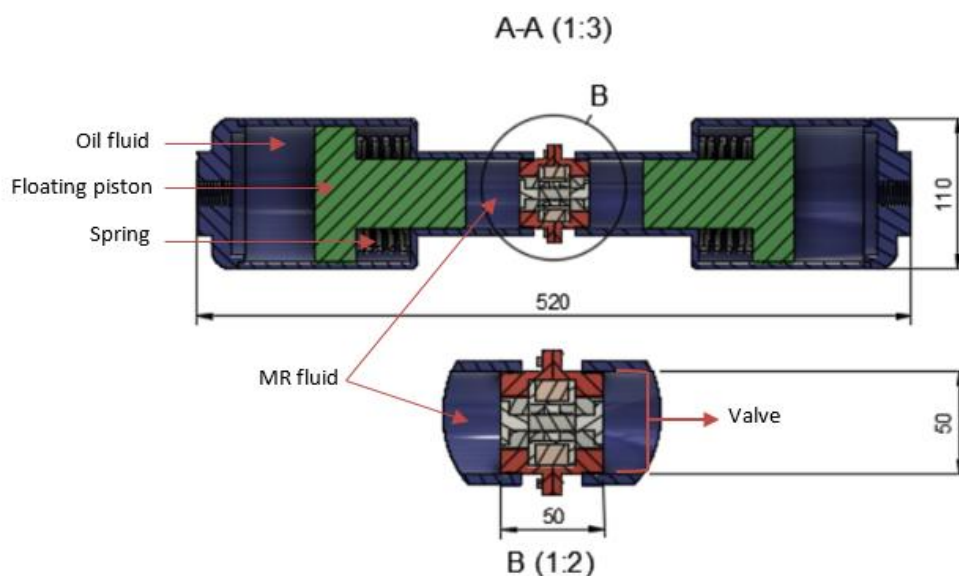
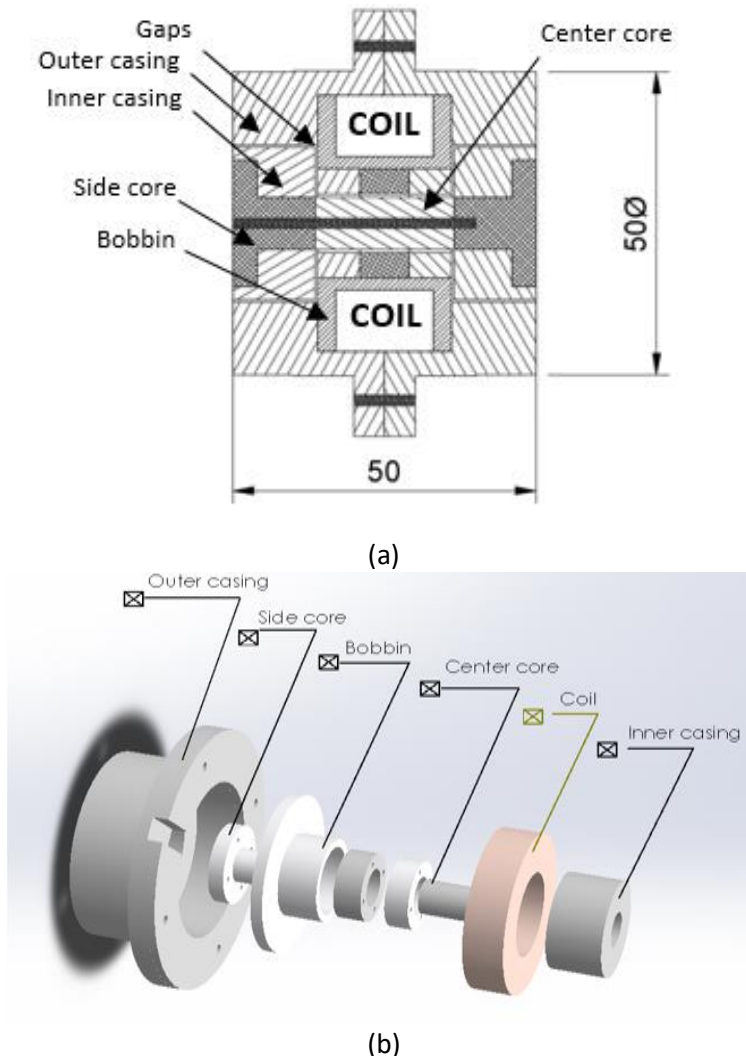

**Fig. 2.** External seismic damper design

As the main aim of this design is to reduce the MR fluids consumptions which will lead to cost savings, the booster type arrangement is used. Unlike the conventional MR damper design, in the booster type arrangement, the MR fluids is placed only in the surrounding area of the valve. Meanwhile, the remaining areas of the cylinder are filled with the ordinary hydraulic fluids. The area which MR fluid placed is determined by the length of displacement of the floating piston in the damper. In this design, the maximum stroke of the damper is set to 10 cm which is justified through the magnitude calculator [14] based on the assumption that the damper will be subjected to earthquake scale up to 7.8.

The valve itself, in particular, is a new modular valve design that has a meandering structure that aims to expand the effective area. The terms “modular structure” is stated due to the capability of the valve to be extended through module expansion. In this way, the range of pressure drop controllability can be easily modified and the flexible range of operation can be achieved. The

segregation of valve into modular sections also will ease the fabrication process [15]. In specific, as depicted in Figure 3, each module consists of the center cores, outer and inner casing that are made of 430 stainless steel and side core, bobbin and some center cores that are made of aluminum 1100. These materials are selected and arranged in such manner so that the intersection between the MR fluid channel and magnetic fluxes will be maximized. In this study, the magnetic fluxes are generated by an electromagnetic coil that is formed by 900 turns of 28 AWG copper wire, that is chosen based on the space availability of the coil bobbin.



**Fig. 3.** Illustration of MR valve parts. (a) 2D cross-section view, (b) 3D exploded view

## 2. Analytical Model

The performance of a valve is determined by its ability to regulate fluid flow through pressure drop generation. In the case of conventional valve where a plug is moved to block the flow channel, the pressure drop is generated through drag force. However, in an MR valve, there is no moving parts involved and thus the pressure drop is not generated from drag force but from shear stress of the fluid itself. Thanks to the ability of the MR fluid to have altered shear stress value to magnetic field, the generated pressure drop can be regulated through magnetic field strength control. In general, the pressure drop of an MR valve is generated from two sources; the pressure drop coming from the

viscous properties of the MR fluid and pressure drop from the field dependent yield stress of the fluid. Overall, the basic expression of pressure drop in an MR valve can be stated by the following equations [15].

$$\Delta P = \Delta P_{viscous} + \Delta P_{yield} \quad (1)$$

$$\Delta P_{viscous} = \frac{6\eta QL}{\pi d^3 R} \quad (2)$$

$$\Delta P_{yield} = \frac{c\tau(B)L}{d} \quad (3)$$

Eq. (2) and (3) expressed the general analytical model of MR fluid pressure drop in an annular channel. Eq. (2), in particular, shows that the MR fluid viscous pressure drop ( $\Delta P_{viscous}$ ) proportionally relates to the fluid viscosity ( $\eta$ ), flow rate of the fluid (Q), length of annular channel (L), inverse to the channel radius (R) and cubically inverse to the valve gaps (d). Meanwhile, as shown in Eq. (3), the field dependent pressure drop is proportional to the field-dependent yield stress value ( $\tau(B)$ ) of MR fluid, annular channel length (L), and flow-velocity profile coefficient (c) but inverse to the gap size (d). The coefficient c is obtained by calculating the ratio between field-dependent pressure drop and viscous pressure drop using the approximation function as defined by Nguyen *et al.*, (2008) [16] in the following Eq. (4).

$$c = 2.07 + \frac{12Q\eta}{12Q\eta + 0.8\pi R d^2 \tau(B)} \quad (4)$$

For the radial gap, the viscous and field dependent pressure drop can be expressed in the Eq. (5), (6) as shown below [15].

$$\Delta P_{viscous} = \frac{6\eta Q}{\pi d^3} \ln \left( \frac{R_o}{R_i} \right) \quad (5)$$

$$\Delta P_{yield} = \frac{c\tau(B)}{d} (R_o - R_i) \quad (6)$$

The viscous pressure drop is directly proportional to the fluid viscosity ( $\eta$ ), flow rate of the fluid (Q) and  $\ln \left( \frac{R_o}{R_i} \right)$ , but inversely-cubical to the valve gaps (d).  $R_o$  and  $R_i$  are the outer and inner radius of the radial gaps as shown in Figure 4. The yield pressure drop is proportional to the field-dependent yield stress value ( $\tau(B)$ ) of MR fluid and the coefficient of flow-velocity profile (c) and inversely to the gap size (d).

The total value of the pressure drop can be calculated by the addition of all pressure drop values on the annular and radial gaps depend on the valve design. The valve design has a meandering path with three annular gaps and two radial gaps. It is shown in Figure 4. The red and green color are the annular gap. The blue one is a radial gap. As shown in the design, the total pressure drop of that valve design can be determined by the following Eq. (7) below.

$$\Delta P_{valve} = 2(\Delta P_{annular1}) + (\Delta P_{annular2}) + 2(\Delta P_{radial})$$

$$\Delta P_{valve} = 2 \left[ \frac{6\eta QL_{a1}}{\pi d_a^3 R_{a1}} + \frac{c_{a1}\tau_{a1}(B)L_{a1}}{d_a} \right] + \left[ \frac{6\eta QL_{a2}}{\pi d_a^3 R_{a2}} + \frac{c_{a2}\tau_{a2}(B)L_{a2}}{d_a} \right] +$$

$$2 \left[ \frac{6\eta Q}{\pi d_r^3} \ln \left( \frac{R_1}{R_0} \right) + \frac{c_r \tau_r(B)}{d_r} (R_1 - R_0) \right] \quad (7)$$

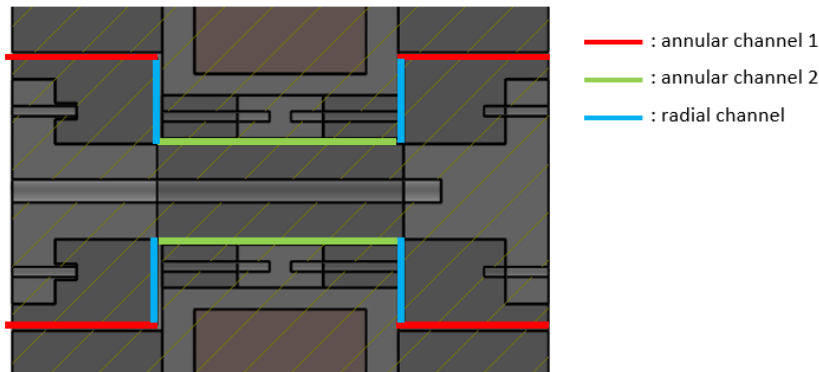

**Fig. 4.** The flow path of annular channel (red; green) and radial channel (blue)

### 3. Results and Discussions

#### 3.1 Pressure Drop Prediction

The discussion of results is presented in two main aspects, the MR valve generated pressure drop and the projections of MR valve performance to the damping characteristics of the seismic damper. In the MR valve discussion section, the discussions are split into two sub-topics, the variations of MR valve generated pressure drop as a result of electromagnet current adjustment and the variations of MR valve generated pressure drop. Meanwhile, in the MR damper discussion section, the performance of MR valve is used to predict the performance of the seismic damper in generating adjustable damping force. As the estimation of pressure drop requires several parameters definition, the parameters used in this study are shown in Table 1 and Figure 5.

**Table 1**

The parameters data of the MR valve design

Parameters	Descriptions	Units	Value
$\eta$ (MRF132DG)	Fluid viscosity	Pa s	0.112
Q	Flow rate	mL/s	360
$d_a$	Annular gap	Mm	0.5
$d_r$	Radial gap	Mm	0.5
$L_{a1}$	Annular channel length 1	Mm	15
$L_{a2}$	Annular channel length 2	Mm	20
$R_1$	Outer radius of radial gap	Mm	13
$R_0$	Inner radius of radial gap	Mm	5
$R_{a1} = R_1$	Annular radius gap 1	Mm	13
$R_{a2} = R_0 - d_a$	Annular radius gap 2	Mm	4.5
$R_p$	Piston radius	Mm	25

MR: magnetorheological

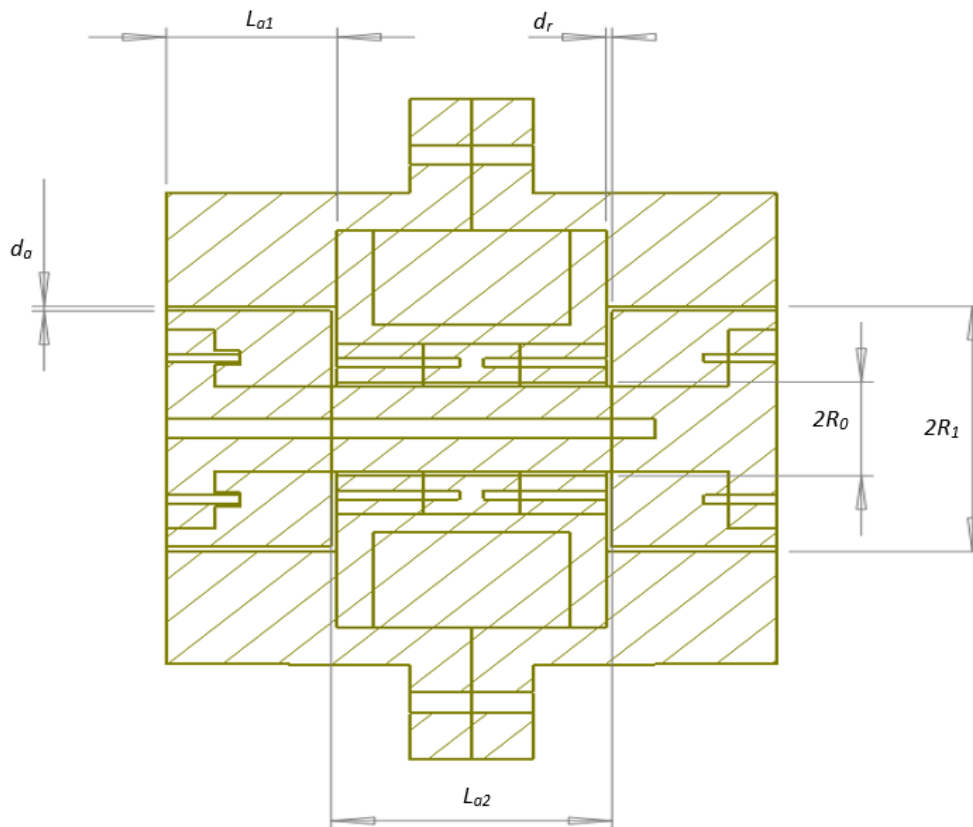

Fig. 5. Dimensions of magnetorheological valve

### 3.1.1 The effect of current input variations

In order to estimate the result of the pressure drop affected by the current input, the yield stress value can be expressed as mentioned in Ichwan *et al.*, 2008 by the following equation

$$\begin{aligned} \tau_y(B) &= -58.92B^3 + 74.66B^2 + 35.74B - 3.387, & \text{for } \tau_y(B) > 0 \\ \tau_y(B) &= 0, & \text{for } \tau_y(B) \leq 0 \end{aligned} \quad (8)$$

where  $B$  is the magnetic flux density in Tesla. The magnetic flux density is affected by the number of coil turns, current input and the type of the coil. The coil is made of a copper wire 28 AWG with 900 turns of coils. This coil has 0.3211 mm diameter with 213  $\Omega$ /km and the maximum current 1.4 A. As mentioned in Imaduddin *et al.*, 2015, since the number of turns in the coil was already determined and the permeability of magnetic material was assumed to follow the B-H curves of AISI 1010, the magnitude of magnetic flux density will be determined by the magnitude of the current input. But, the magnitude of magnetic flux density for each zone is difficult to be calculated analytically. Therefore, to determine the magnetic flux density required a support software to simulate the design valve of each zone. The simulation uses finite element method-based (FEMM) for the magnetic problem [17].

The simulation is 2D simulation axisymmetric. It shows the magnetic flux density flow path on the valve. The result of the magnetic flux density on each area will differ depending on the type of the materials. The materials which have good permeability obtain the flow of the magnetic flux density. The result of the simulation is shown in Figure 6.

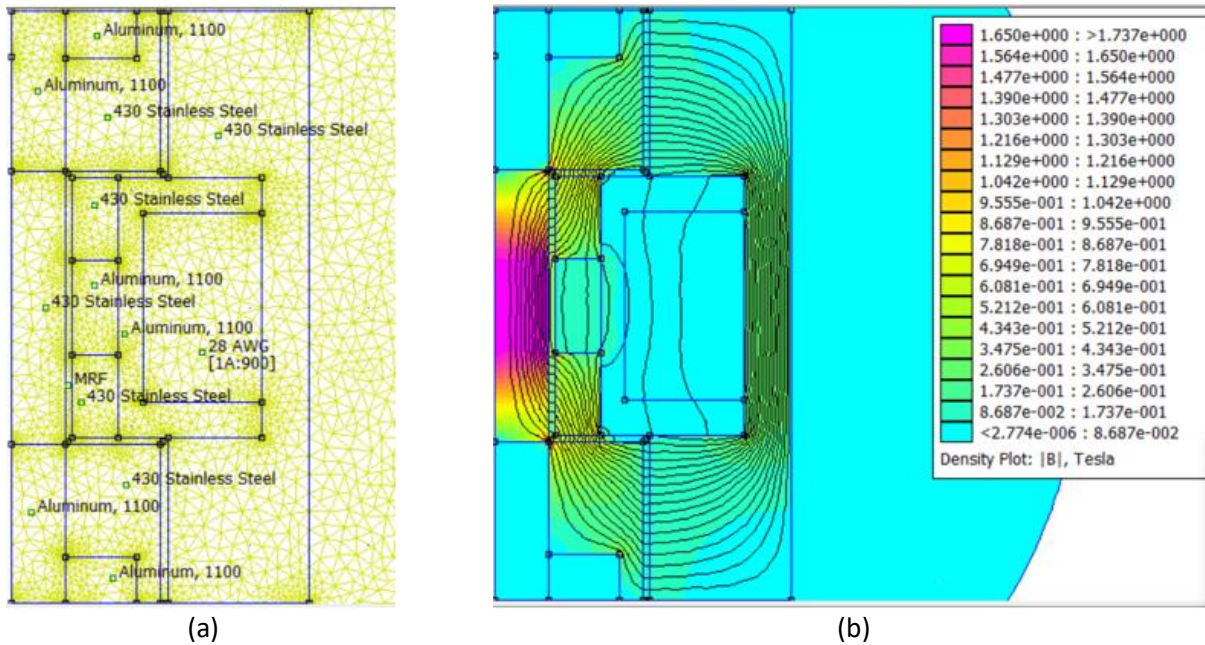

**Fig. 6.** FEMM simulation result. (a) Meshed model of the MR valve with FEMM magnetic simulation software; (b) Result of magnetic flux density flow path in FEMM with 1 A current input. MR: magnetorheological; FEMM: finite element method-based software

Figure 7 shows the result of magnetic flux density for 0.5 gap size with variations of current input 0.5 A, 0.75 A, 1.0 A and 1.4 A. The increasing current input to the MR fluid valve makes the magnitude of magnetic flux density increase significantly. It will make the pressure drop from the yield increase in accordance with the Eq. (3), (6) and (8). The value of the magnetic flux density for 0.5 A current input is 0.14 T in annular gap 1; 0.37 T in annular gap 2 and 0.55 T in the radial gap. For 0.75 A current input is 0.15 T in annular gap 1; 0.47 in annular gap 2 and 0.63 in radial gap. For 1.0 A current input is 0.17 T in annular gap 1; 0.5 T in annular gap 2 and 0.68 T in radial gap. For 1.4 A current input is 0.19 T in annular gap 1; 0.62 T in annular gap 2 and 0.75 T in the radial gap.

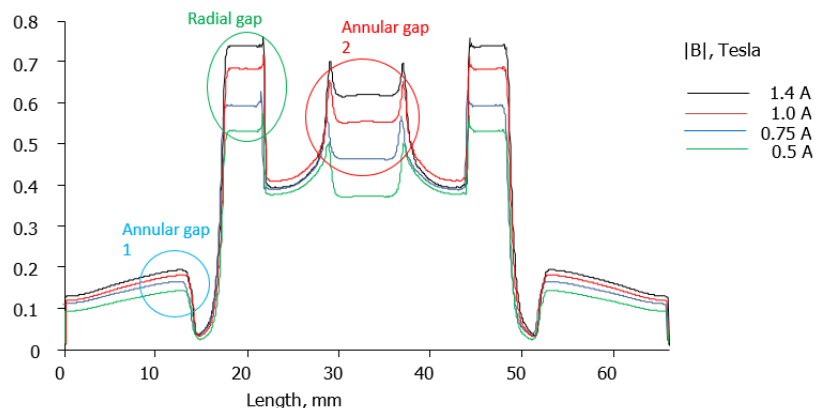
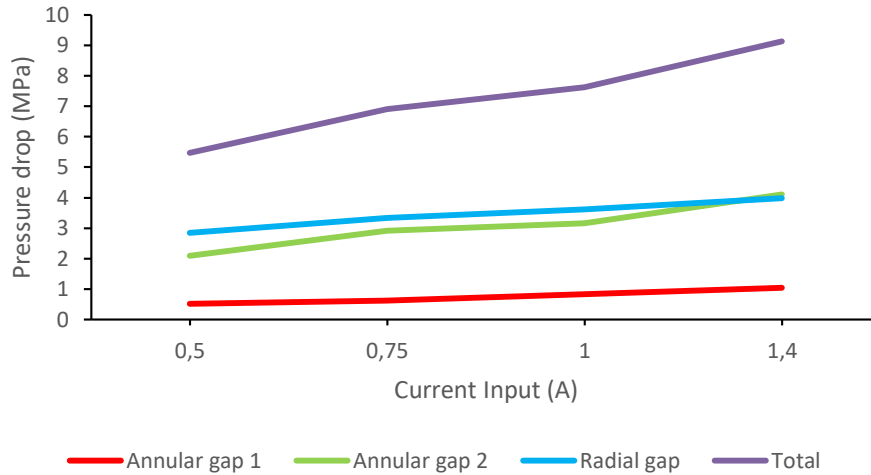

**Fig. 7.** Simulation result of magnetic flux density along the MR fluid flow path for 0.5 mm gap size in FEMM software with current input variations

The predict of the yield stress value can be calculate by the Eq. (8) with the magnetic flux density which is obtained from the simulation. The yield stress value will be used in the Eq. (3), (4) and (6) to calculate the pressure drop predictions. The result of the pressure drop predictions on annular gap



1, with variations of current inputs 0.5 A; 0.75 A; 1.0 A; 1.4 A are 0.53 MPa; 0.63 MPa; 0.83 MPa; 1.04 MPa. The result predictions of annular gap 2 are 2.09 MPa; 2.92 MPa; 3.16 MPa; 4.10 MPa. For the radial gap pressure drop predictions are 2.85 MPa; 3.34 MPa; 3.62 MPa; 3.98 MPa. The results show that the pressure drop value increases directly proportional to the higher current input. The total pressure drop value of 0.5 A; 0.75 A; 1.0 A; 1.4 A current input are 5.48 MPa; 6.90 MPa; 7.63 MPa; 9.13 MPa as shown in Figure 8.



**Fig. 8.** Pressure drop prediction of magnetorheological valve

### 3.1.2 Pressure drop prediction of off-state condition

In addition to predict the pressure drop with the variations of the current input, the off-state condition of MR valve which is without current input also must be calculated. The estimation of pressure drop value on off-state condition can be expressed with the Eq. (2) and (5). The peak pressure drop prediction results of the calculation are 0.96 MPa in annular gap 1; 3.73 MPa in annular gap 2 and 1.60 MPa in the radial gap. The total pressure drop on the off-state condition is 7.27 MPa as shown in Figure 9.

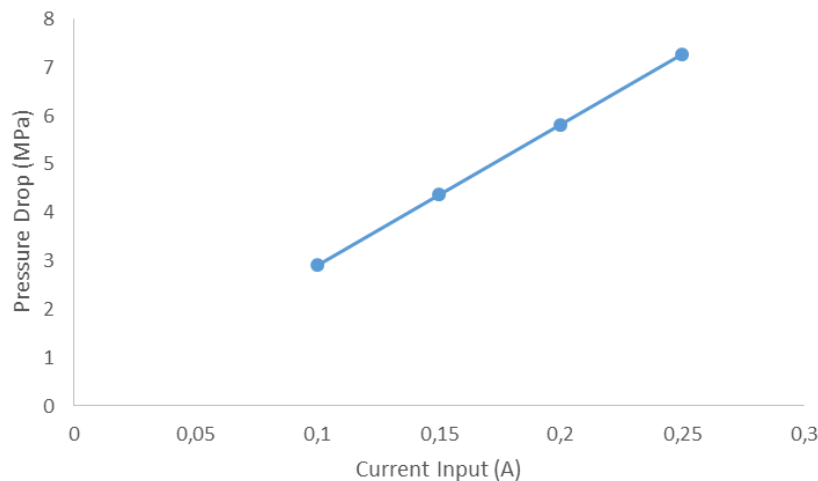

**Fig. 9.** Pressure drop prediction of off-state condition

### 3.2 Damping Force Prediction of The MR Valve

Since the value of the pressure drop is calculated, the magnitude of the damping force that occurs can be calculated by the following equation [18, 19]

$$\Delta P = \frac{F_d}{A_p} \quad (9)$$

$$A_p = \pi R_p^2 \quad (10)$$

where  $F_d$  is a damping force prediction and  $R_p$  is a piston radius. The damping force for the MR valve on off-state condition is 10.5 kN. In this case,  $\Delta P_{viscos}$  is used to calculate the off-state damping force. Besides the off-state condition, the on-state condition with current inputs 0.5 A; 0.75 A; 1.0 A; 1.4 A are calculated. The calculation of the damping force for the on-state condition uses the  $\Delta P_{yield}$  on 361 mL/s of MR fluids flow rate. The results show that the magnitude of the damping force increases in proportion to the increase in current input as shown in Figure 10.

From the calculation, the maximum damping force value is 17.91 kN on 1.4 A current input. With small dimensions and lower consumption of MR fluids this design could reach high damping force. Compared to MR seismic dampers that had already existed, this design could be said to be superior because it has several advantages.

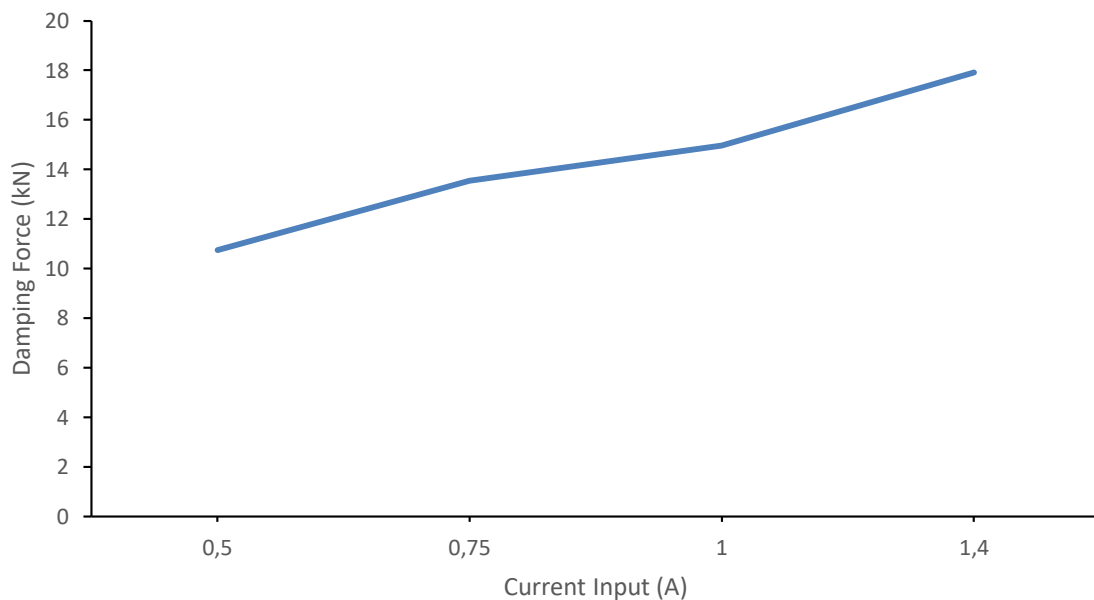

**Fig. 10.** Damping force value due to the influence of current input

## 4. Conclusions

A new design of MR valve with a magnetorheological fluid and the meandering flow path is presented. This MR damper device is designed as one of the supporting devices to help reduce losses which is caused by earthquake disaster. This design is proposed as an effort to increase the pressure drop with limited dimensions which aims to save space and costs. The pressure drop prediction is determined with a derivation of the mathematical model and supported by magnetic software simulation which is called FEMM. The performances of the MR valve is evaluated based on the effect

of the applied current input and the gap size in the MR valve flow path. According to the calculation and simulation, the magnitude of the pressure drop increases directly proportional to the increased of current input. The damping force can be calculated through the pressure drop value.

### Acknowledgement

This research was funded by a Mandatory Research Grant 2019 and partial funding by USAID through Sustainable Higher Education Research Alliances (SHERA) Program - Centre for Collaborative (CCR) National Center for Sustainable Transportation Technology (NCSTT) with Contract No. IIE0000078-ITB-1.

### References

- [1] Naryanto, Heru Sri. "Analisis Potensi Kegempaan dan Tsunami di Kawasan Pantai Barat Lampung Kaitannya dengan Mitigasi dan Penataan Kawasan." *Jurnal Sains dan Teknologi Indonesia* 10, no. 2 (2012).
- [2] Usher, Kim, and Lidia Mayner. "Disaster nursing: a descriptive survey of Australian undergraduate nursing curricula." *Australasian Emergency Nursing Journal* 14, no. 2 (2011): 75-80.
- [3] Lestari, Ayu Widya, and Cut Husna. "Sistem peringatan bencana dan mobilisasi sumber daya dalam menghadapi bencana gempa bumi dan tsunami." *Idea Nursing Journal* 8, no. 2 (2017): 23-29.
- [4] Heysami, Alireza. "Types of dampers and their seismic performance during an earthquake." *Current world environment* 10 (2015): 1002-1015.()
- [5] Badan Nasional Penanggulangan Bencana. "Data informasi bencana Indonesisa. Tren Kejadian Bencana 10 Tahun Terakhir."
- [6] Tao, Rongjia. *Electro-rheological Fluids and Magneto-rheological Suspensions: Proceedings of the 12th International Conference, Philadelphia, USA, 16-20 August 2010*. World Scientific, 2011.
- [7] Bankar, V.K. and Aradhye, A.S. "A Review on Active, Semi-active and Passive Vibration Damping." *International Journal of Current Engineering and Technology* 6, no. 6 (2016).
- [8] Aziz, Siti Aishah Abdul, Saiful Amri Mazlan, Nik Intan Nik Ismail, U. Ubaidillah, Seung-Bok Choi, Muntaz Hana Ahmad Khairi, and Nurul Azhani Yunus. "Effects of multiwall carbon nanotubes on viscoelastic properties of magnetorheological elastomers." *Smart Materials and Structures* 25, no. 7 (2016): 077001.
- [9] Ubaidillah Mazlan, S.A. Sutrisno, J. Zamzuri, H. (2014). Potential Applications of Magnetorheological Elastomers. Saiful Amri, Joko Sutrisno, and Hairi Zamzuri. "Potential Applications of Magnetorheological Elastomers." *Applied Mechanics and Materials* 663, (2014): 695-699.
- [10] Schwartz, M. *Smart Material*. Taylor and Francis Group, (2009)
- [11] Sabino, Ubaidillah, Khisbullah Hudha, and Hishamuddin Jamaluddin. "Simulation and experimental evaluation on a skyhook policy-based fuzzy logic control for semi-active suspension system." *Int. J. Structural Engineering* 2, no. 3 (2011): 243-272.
- [12] Bhise, Ankita R., Rutuja G. Desai, R. N. Yerrawar, A. C. Mitra, and R. R. Arakerimath. "Comparison between passive and semi-active suspension system using matlab/simulink." *IOSR Journal of Mechanical and Civil Engineering* 13, no. 4 (2016): 1-6.
- [13] Imaduddin, Fitriani, Saiful Amri Mazlan, Hairi Zamzuri, and Izyan Iryani Mohd Yazid. "Design and performance analysis of a compact magnetorheological valve with multiple annular and radial gaps." *Journal of Intelligent Material Systems and Structures* 26, no. 9 (2015): 1038-1049.
- [14] Raymond, J."Earthquake Seismometer Equations Calculator Earth Science Geology Geophysics Seismology Formula."
- [15] Ichwan, B., S. A. Mazlan, F. Imaduddin, T. Koga, and M. H. Idris. "Development of a modular MR valve using meandering flow path structure." *Smart Materials and Structures* 25, no. 3 (2016): 037001.
- [16] Nguyen, Quoc-Hung, Seung-Bok Choi, and Norman M. Wereley. "Optimal design of magnetorheological valves via a finite element method considering control energy and a time constant." *Smart Materials and Structures* 17, no. 2 (2008): 025024.
- [17] Ubaidillah, Imaduddin, Fitriani, Yancheng Li, Saiful Amri Mazlan, Joko Sutrisno, Tsuyoshi Koga, Iwan Yahya, and Seung-Bok Choi. "A new class of magnetorheological elastomers based on waste tire rubber and the characterization of their properties." *Smart Materials and Structures* 25, no. 11 (2016): 115002.
- [18] Oh, Jong-Seok, Tae-Hoon Lee, and Seung-Bok Choi. "Design and analysis of a new magnetorheological damper for generation of tunable shock-wave profiles." *Shock and Vibration* 2018 (2018).

- 
- [19] Zalewski, R., J. Nachman, M. Shillor, and J. Bajkowski. "Dynamic model for a magnetorheological damper." *Applied Mathematical Modelling* 38, no. 9-10 (2014): 2366-2376.