

Performance Assessment of Passive Heating and Cooling Techniques for Underground Shelter in Equatorial Climate

Open
Access

Azfarizal Mukhtar¹, Khai Ching Ng^{2,*}, Mohd Zamri Yusoff³, Wah Yen Tey^{4,5}, Lit Ken Tan⁵

¹ Department of Mechanical Engineering, International Islamic University Malaysia, Jalan Gombak, 53100 Kuala Lumpur, Malaysia

² Department of Mechanical, Materials and Manufacturing Engineering, The University of Nottingham Malaysia Campus, Jalan Broga, 43500 Semenyih, Selangor Darul Ehsan, Malaysia

³ Centre for Fluid Dynamics, College of Engineering, Universiti Tenaga Nasional (UNITEN), Putrajaya Campus, Jalan IKRAM-UNITEN, 43000 Kajang, Selangor Darul Ehsan, Malaysia

⁴ Department of Mechanical Engineering, Faculty of Engineering, UCSI University, 1, Jalan Puncak Menara Gading, Taman Connaught, 56000 Kuala Lumpur, Malaysia

⁵ Takasago i-Kohza, Malaysia-Japan International Institute of Technology, Jalan Sultan Yahya Petra, Kampung Datuk Keramat, 54100 Kuala Lumpur, Malaysia

ARTICLE INFO

Article history:

Received 9 September 2018

Received in revised form 16 October 2018

Accepted 23 April 2019

Available online 19 September 2019

ABSTRACT

Underground shelter serves as a specialized building structure that can provide either heating or cooling to occupants during different climates depending on the requirements. In this study, the CFD model of the 3D underground shelter was simulated at different seasons of the year in Malaysia. Initially, the soil temperature distributions at various depths were numerically investigated using the Kasuda Model; this model showed that at a depth of more than 10 m, the soil temperature remains constant. The soil thermal properties were considered in our numerical model simulated using ANSYS Fluent. The CFD model was firstly validated with the published experimental data, before it was used to simulate the passive heating and cooling operations within the underground shelter. The results indicated that the temperature of the underground shelter ranged between 27.80°C and 32.10°C from day to night. This assessment was evaluated in the coldest and warmest months of the year. Finally, the simulated room temperatures were compared against the standard Malaysian comfort temperature. It was found that natural ventilation alone could not assure a good thermal comfort level within the underground shelter.

Keywords:

Underground Shelter; CFD; Soil
Temperature; Comfort Temperature

Copyright © 2019 PENERBIT AKADEMIA BARU - All rights reserved

1. Introduction

With the challenges of global warming, the concept of energy reduction without compromising the indoor thermal comfort has become a substantial component in designing low energy buildings [1,2]. The latest research has found that underground shelters or buildings are alternatives to the conventional buildings (above ground) due to their potential lower energy consumptions [3,4]. As compared to a conventional building, Anselm [5] has proven that underground shelters are able to

* Corresponding author.

E-mail address: ngkhaiching2000@yahoo.com (Khai Ching Ng)

reduce the yearly heating and cooling loads as well as to keep the indoor temperature stable during different climates. This is due to the high thermal inertia and heat capacity of the soil [6].

Several works [3, 7-10] related to the evaluations of energy performance and heat loss of the underground building for different climates and regions have been reported. Nevertheless, research that focuses on equatorial climate is rather limited. Therefore, we have conducted a CFD assessment in the passive heating and cooling operations of an underground shelter by considering the Malaysian climate. We have assessed the comfort temperature for indoor occupants in the shelter as well. The shelter model developed by King [11] previously was selected in the current study, as the experimental data is available.

2. Study Area

Malaysia is considered a maritime country near the equator, lying $2^{\circ}30'$ in the North latitude and $112^{\circ}30'$ in the East longitude. The South China Sea separates the west and east regions. As a tropical country, Malaysia experiences high temperature, illumination, and relative humidity levels, variable wind condition, and long hours of sunshine with rainfall occurring throughout the year. The average sunshine duration is around 6 hours. The daily temperature in Malaysia ranges from 24°C to 38°C . The lowest temperature is normally found during night time. The mean daily humidity can be as low as 42%, to as high as 94%. The wind speed and direction in Peninsular Malaysia are influenced by the monsoon seasons. The annual evaporation rate in Malaysia is about 4mm–5mm per day depending on the cloud cover and the air temperature. Due to its hot and humid climate, cooler day exhibits lower evaporation rate and higher relative humidity as compared to warmer days [12]. In the current study, the weather data of a town known as Petaling Jaya (PJ) located in the state of Selangor, Malaysia has been utilized.

3. Research Method

3.1 Temperature Distribution Model

The passive thermal performance for underground shelters is dependent on several factors such as soil temperature, ambient temperature and wind speed. The soil is not a good insulator, but a terrific moderator for temperature fluctuation [5] in which it does not respond to daily temperature variations and it reacts gradually to seasonal changes. Soil temperature can be affected by variables such as topography, meteorology and sub-surface. Considering these factors, soil depth temperature is required when analysing the room temperature of underground shelter numerically. The temperature variation can be modelled based on the Kasuda's model [13], where the soil temperature is a function of time (day), soil depth and air temperature

$$T(z, t) = T_{mean} - \left[\left(T_{amp} e^{-z \left(\frac{\pi}{365\alpha} \right)^{1/2}} \right) \cos \left\{ \left(\frac{2\pi}{365} \right) \left((t - t_0) - \left(\frac{z}{2} \right) \left(\frac{365}{2\alpha} \right)^{1/2} \right) \right\} \right] \quad (1)$$

Here, $T(z, t)$ is the undisturbed soil temperature at time t (day) and depth z (m), T_{mean} is the mean surface temperature, T_{amp} is the amplitude of surface temperature, α is the thermal diffusivity of the soil (m^2/day) and t_0 is the day of the year with minimum surface temperature. T_{mean} , T_{amp} and t_0 can be determined from the meteorology data. However, α should be determined based on the physical soil characteristic such as soil type and moisture content.

In order to apply Eq. (1) for Malaysia’s climate, the data provided by the Malaysian Meteorological Department was utilised. The data was generated hourly starting from 0001H, 1st January 2016 until 2359H, 31st December 2016. Table 1 and Table 2 show the monthly average day and night temperatures (derived from the hourly temperature). According to the metrological data shown in Table 1 and Table 2, the lowest and the highest temperatures recorded were 22.50°C and 36.90°C, respectively. The temperature amplitude was 6.48°C and t_0 was taken from the lowest daily average temperature shown in Figure 1. Meanwhile, the mean annual air temperature was 28.95°C. The thermal diffusivity, α was 0.06 m²/day with R² value of 0.9999 taken from Yusof *et al.*, [14]. Substituting the above-mentioned values into Eq. (2), the soil temperature can be predicted as

$$T(z, t) = 28.95 - 6.48 e^{(-z \times [\frac{\pi}{366\alpha}]^{0.5})} \cos \left[\frac{2\pi}{366} (t - 169) - z \times [\frac{\pi}{366\alpha}]^{0.5} \right] \quad (2)$$

Table 1
Climate Data for Petaling Jaya (daytime)

Month	Jan	Feb	Mar	Apr	May	Jun	Jul	Aug	Sep	Oct	Nov	Dec	Yearly
Record High Temp (°C)	35.9	35.7	36.6	36.9	36.2	35.7	35.8	34.8	34.8	34.2	34.1	35.1	36.9
	0	0	0	0	0	0	0	0	0	0	0	0	0
Record Low Temp (°C)	23.8	25.3	25.5	24.6	23.4	23.4	29.7	23.8	29.6	24.0	23.3	22.5	22.5
	0	0	0	0	0	0	6	0	6	0	0	0	0
Average Temp (°C)	30.6	30.6	31.3	31.4	30.5	30.1	29.7	30.3	29.6	29.6	28.5	28.6	30.1
	0	0	6	5	4	4	6	6	6	7	4	8	1
Amplitude Temp (°C)	5.99	6.18	5.82	7.20	6.39	7.49	7.92	4.92	6.56	6.10	5.64	7.50	6.48
Record High Surface Wind (m/s)	6.70	5.00	5.50	5.00	4.90	6.30	5.20	5.10	3.90	5.00	4.20	4.70	5.00

Table 2
Climate Data for Petaling Jaya (night time)

Month	Jan	Feb	Mar	Apr	May	Jun	Jul	Aug	Sep	Oct	Nov	Dec	Yearly
Record High Temp (°C)	32.9	32.9	34.6	33.6	32.9	32.8	33.9	32.8	32.9	32.5	29.8	32.9	34.6
	0	0	0	0	0	0	0	0	0	0	0	0	0
Record Low Temp (°C)	25.3	25.0	23.7	24.9	23.6	23.3	27.4	24.7	28.0	23.6	22.8	22.5	22.5
	0	0	0	0	0	0	1	0	1	0	0	0	0
Average Temp (°C)	27.6	27.7	28.6	28.8	27.9	27.7	27.4	28.6	28.0	27.7	26.4	26.6	27.7
	6	7	2	0	2	8	1	6	1	2	8	5	9
Amplitude Temp (°C)	5.99	6.18	5.82	7.20	6.39	7.49	7.92	4.92	6.56	6.10	5.64	7.50	6.48
Record High Surface Wind (m/s)	3.40	4.30	3.90	3.90	3.80	2.80	2.30	3.40	4.50	3.40	3.10	2.80	3.90

The soil temperature distribution, which was generated from the MATLAB software, was valid up to soil depth of 15m. Figure 2 shows that the soil temperature is almost constant (i.e. mean annual air temperature) at a depth more than 10 m. Therefore, the present results can be used to calculate the heat transfer through the underground shelter in Malaysia.

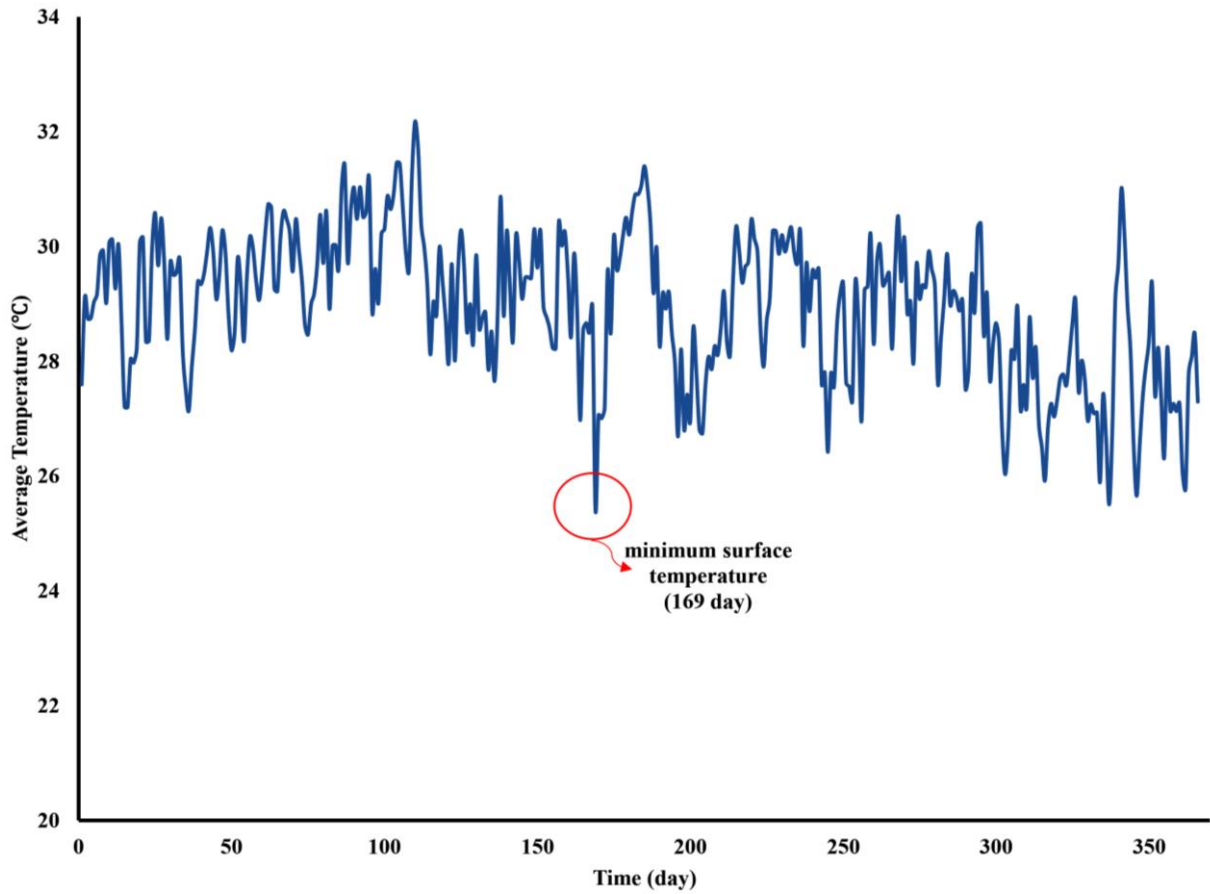

Fig. 1. Daily average temperature of 2016 retrieved from Mukhtar *et al.*, [15]

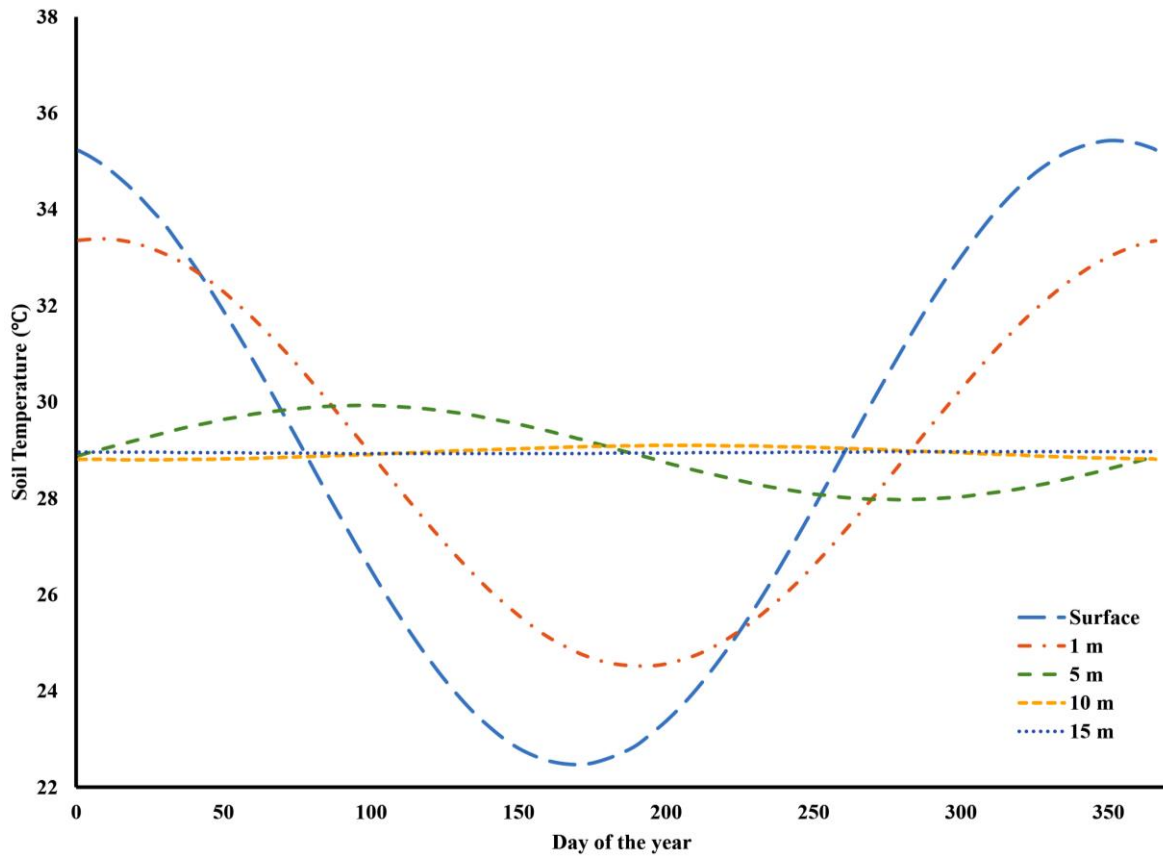

Fig. 2. Soil temperature distribution at various depths

3.2 Mathematical Model

The air inside the shelter was considered as steady, incompressible and turbulent. The flow model involves mass (3), momentum (4) and energy (5) conservation equations

$$\nabla \cdot \vec{v} = 0 \tag{3}$$

$$\nabla \cdot (\rho \vec{v} \vec{v}) = -\nabla p + \nabla \cdot \bar{\tau} - \rho \beta \vec{g} (T - T_o) \tag{4}$$

$$\nabla \cdot (\vec{v} (\rho E + p)) = -\nabla \cdot (k \nabla T) + \Phi + S_h \tag{5}$$

Here, ρ is density, \vec{v} is velocity vector, p is pressure, $\bar{\tau}$ is the viscous stress tensor, \vec{g} is the gravitational acceleration, β is the thermal expansion coefficient, E is the total energy, k is the fluid thermal conductivity, T is the temperature, S_h is a source term and Φ is the viscous dissipation function representing the work done by the viscous forces.

3.3 Numerical Simulation

The numerical results were obtained using ANSYS Fluent, which is the commercial finite-volume solver. A reduced scale experimental model developed by King [11] was used to validate the current CFD model (see Figure 3).

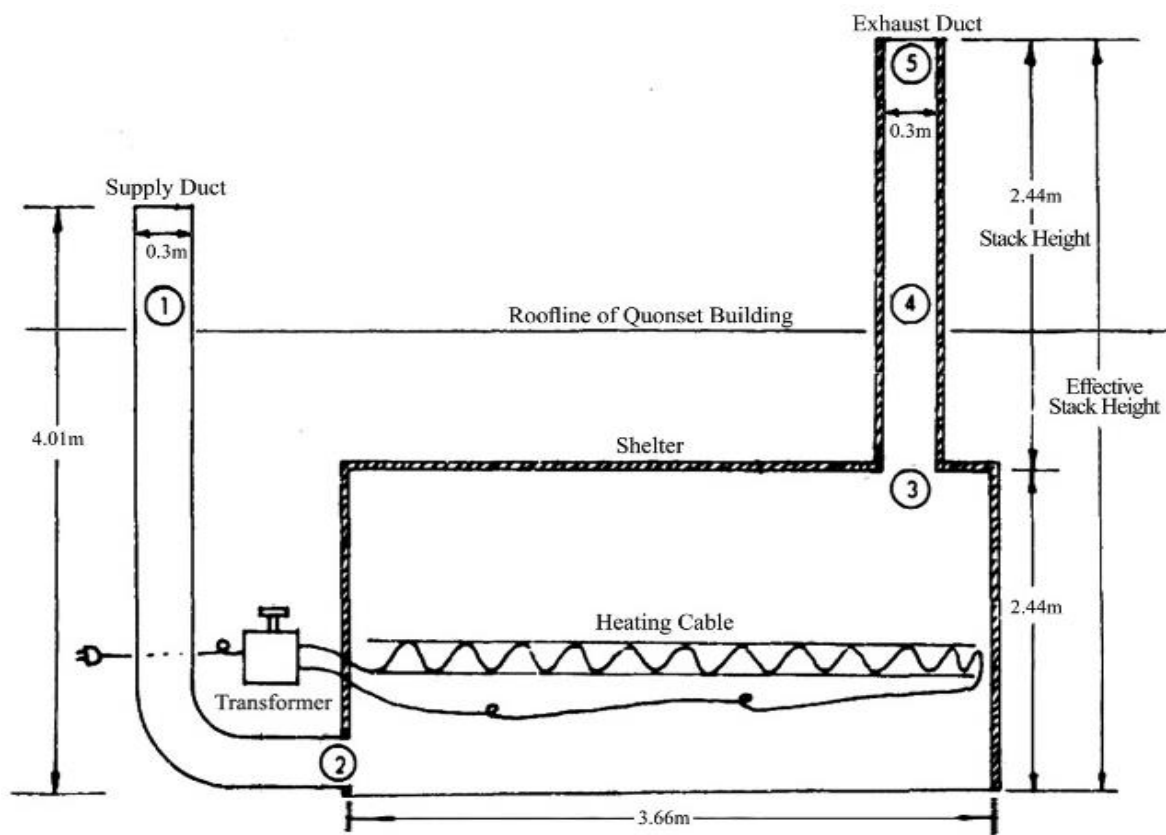

(a)

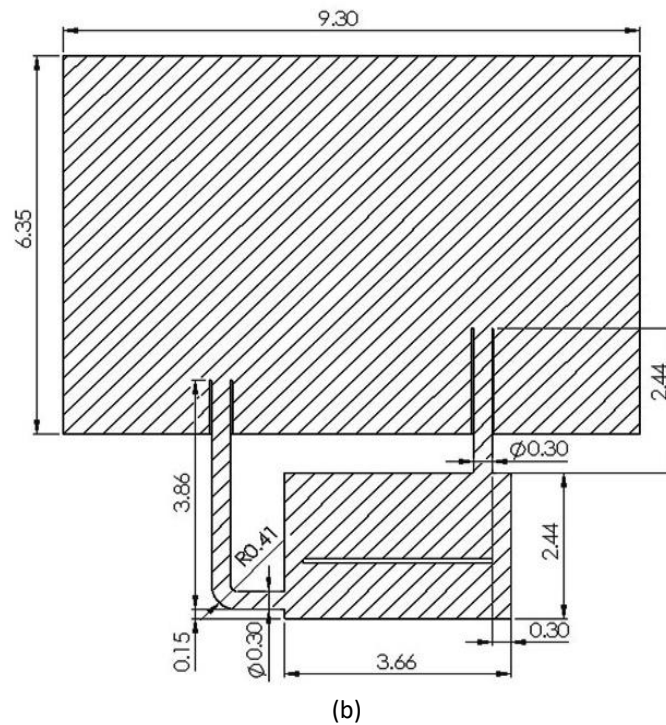

Fig. 3. Schematic drawing and geometry model

A realizable $k - \varepsilon$ model was applied to simulate flow turbulence. The SIMPLEC algorithm was applied for coupling the velocity and pressure variables. The convection terms in the conservation equations were discretized using the second-order upwind schemes. The sparse matrices were solved using the Gauss-Seidel iterative solver coupled with the Algebraic Multi-Grid (AMG) method to accelerate the solution convergence. In this study, the flexible cycle was used in solving the energy equation. Lastly, the solution was executed for approximately 850 iterations to attain a converged solution. Convergence was declared when there were no more obvious fluctuations in velocity, energy and turbulence variables, and the domain has net imbalance of less than 1%. After the simulation, the ventilation rate was calculated using the mass flow rate recorded at the exhaust shaft.

3.3.1 Grid generation and boundary conditions

For the grid generation, the model was discretized using an unstructured mesh (tetrahedral mesh) where a finer grid was generated around critical areas such as ventilation shaft and heating cable. For verification and validation purposes, the boundary condition was similar to the experimental conditions [11]. A constant wind profile was fixed at the domain inlet and zero static pressure at the domain outlet. For the domain wall, a free slip condition was applied. For the walls of the ventilation shaft, the adiabatic and no-slip shear conditions were applied. The heat flux for the heating cable was fixed at 70 W/m^2 [16]. This heating cable was designed to replicate the heat release of an indoor occupant in an enclosed space. The details of boundary conditions are shown in Figure 4.

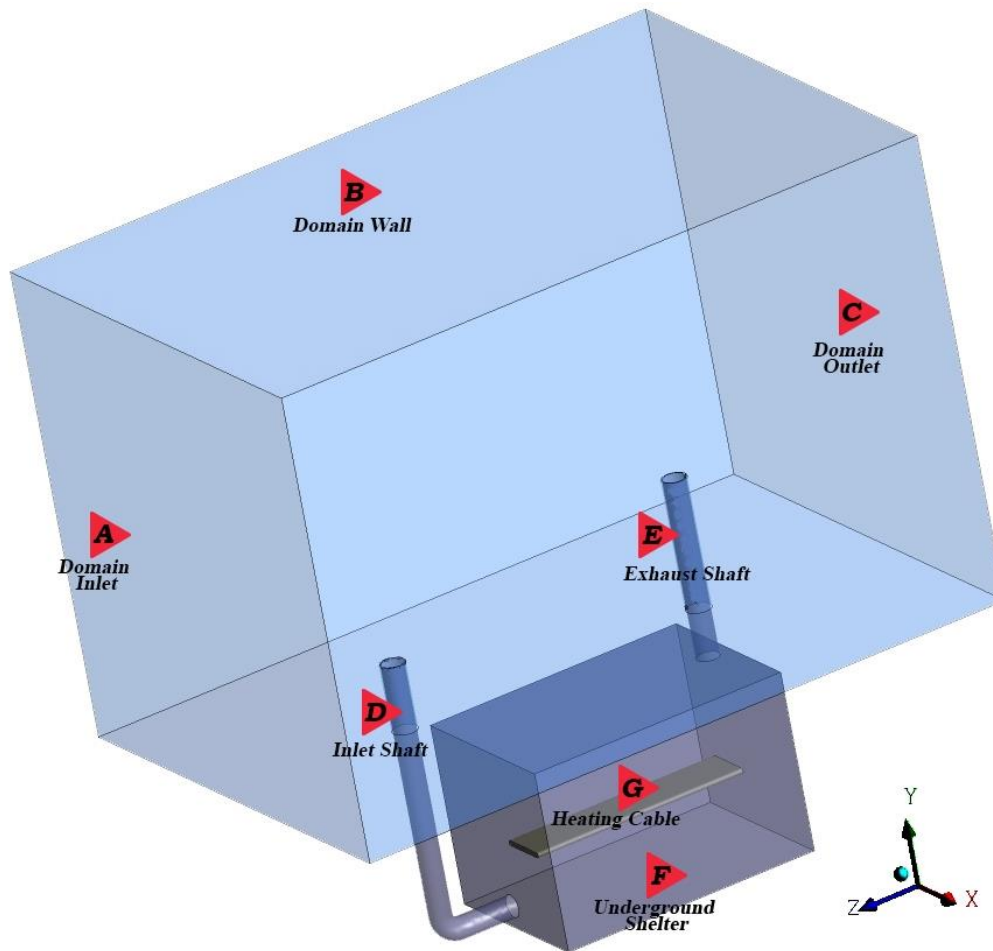

Fig. 4. Boundary conditions

3.3.2 Grid independent test and model validation

The grid independence study was performed by using six different meshes. Figure 5 indicates that the cases employing two larger mesh sizes (i.e. 1.63 and 2.39 million cells) yielded a grid-independent axial velocity result at the exhaust shaft. Therefore, the mesh consisting of 1.63 million cells was selected for subsequent analysis. Next, a systematic validation of the CFD model was performed. The simulated ventilation rate was $0.0456 \text{ m}^3/\text{s}$, which agreed considerably well with that measured by King [11] (i.e. $0.0477 \text{ m}^3/\text{s}$). The percentage difference between these two results was 4.4%. Hence, it can be deduced that this CFD model can be applied to assess the passive heating and cooling operations of underground shelters in Malaysia reliably. The details of the model validation can be found in Mukhtar *et al.*, [17, 18].

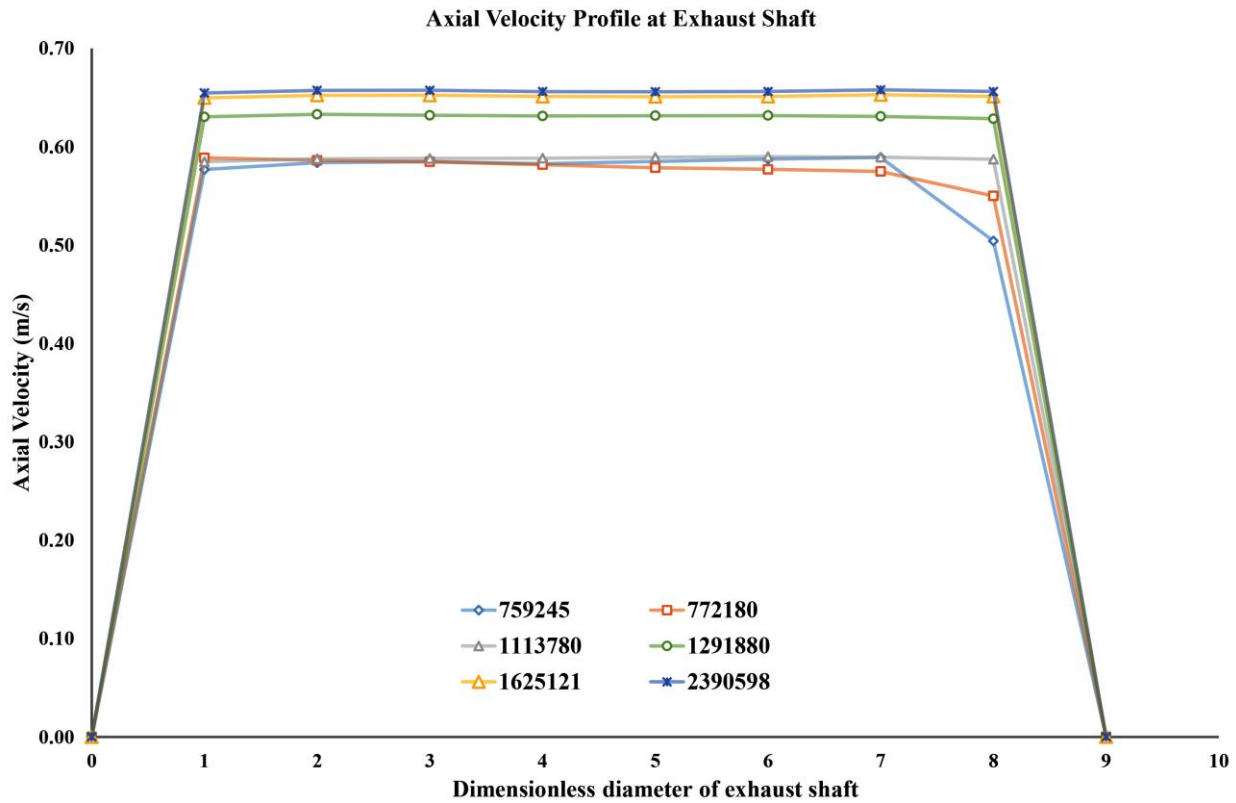

Fig. 5. Grid Independence Test

4. Result and Discussion

4.1 Assessment on the Daytime for Passive Cooling Operation

In order to simulate the temperature distribution inside an underground shelter during daytime, the weather data during the month of April was considered. From Table 1, the highest air velocity of the day was 5 m/s, and the air temperature was 36.90°C. These values were used as boundary conditions for the wind profile at the domain inlet. The temperature of the underground shelter wall was set according to the soil temperature. The temperature contour on the symmetry plane of the underground shelter is shown in Figure 6. When the heating cable was deactivated, the air temperature dropped from 36.90°C (air inlet) to an average of 31°C inside the underground shelter. A similar result was also found when the heating cable was activated, whereby the air temperature dropped to an average of 32.10°C inside the shelter. As seen, the deviation of indoor temperature for these two cases was about 1.10°C. Also, it is important to note that the heat released by a person in an enclosed space can influence the average comfort temperature inside the shelter. In certain occasions, the air temperature inside the shelter (with occupant) was almost similar to the inlet air temperature during daytime. If this condition persists for a long period without any extra ventilation, it would cause thermal discomfort (heat stress) on the occupants.

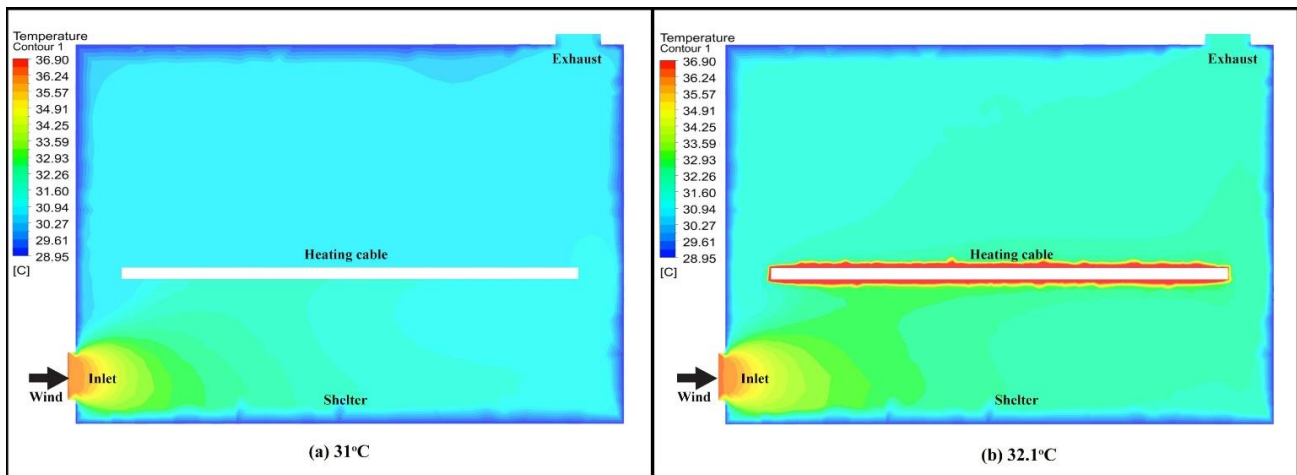

Fig. 6. Static temperature contour on the symmetry plane of underground shelter (daytime)

4.2 Assessment on the Night-time for Passive Heating Operation

For night time, data samples collected from the month of December were used for the simulation purpose. From Table 2, the lowest air velocity of the day was 2.8 m/s, and the air temperature was 22.50°C. Again, these values were used as the wind boundary condition at the domain inlet. As shown in Figure 7, both cases (with/without heating cables) produced almost similar results, whereby the air temperature increased to 29.20°C and 27.80°C, respectively. The temperature deviation for both cases (1.40°C) was slightly higher as compared to that of daytime. In fact, the body heat can raise the effective temperature inside the shelter. Also, the soil could absorb the heat released by the occupant. These findings were consistent with those reported in the previous study [19].

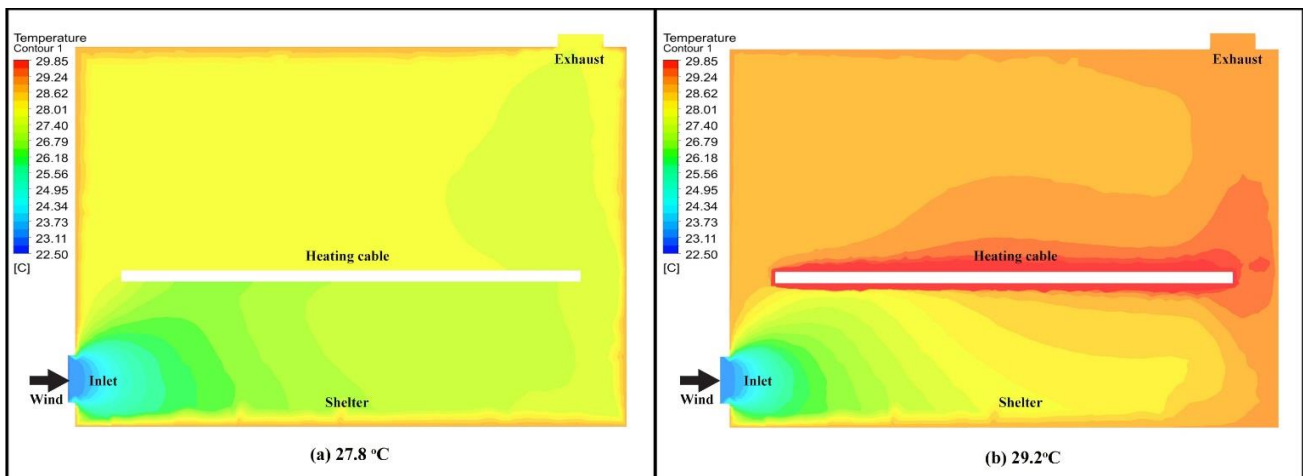

Fig. 7. Static temperature contour on the symmetry plane of underground shelter (night-time)

4.3 Assessment of Temperature Distribution along the Ventilation Shaft

Before evaluating the comfort temperature inside the shelter, the temperature distribution along the ventilation shaft has been analysed. As shown in Figure 8, during daytime, the temperature decreases from 36.90°C (outdoor temperature) to an average of 36.20°C near the shaft exit connected to the shelter, regardless on the operating mode (i.e. heating off and heating on). During night-time (see Figure 9), the temperature along the ventilation shaft increased from 22.50°C (outdoor temperature) to an average of 23.25°C near the shaft entrance connected to the shelter.

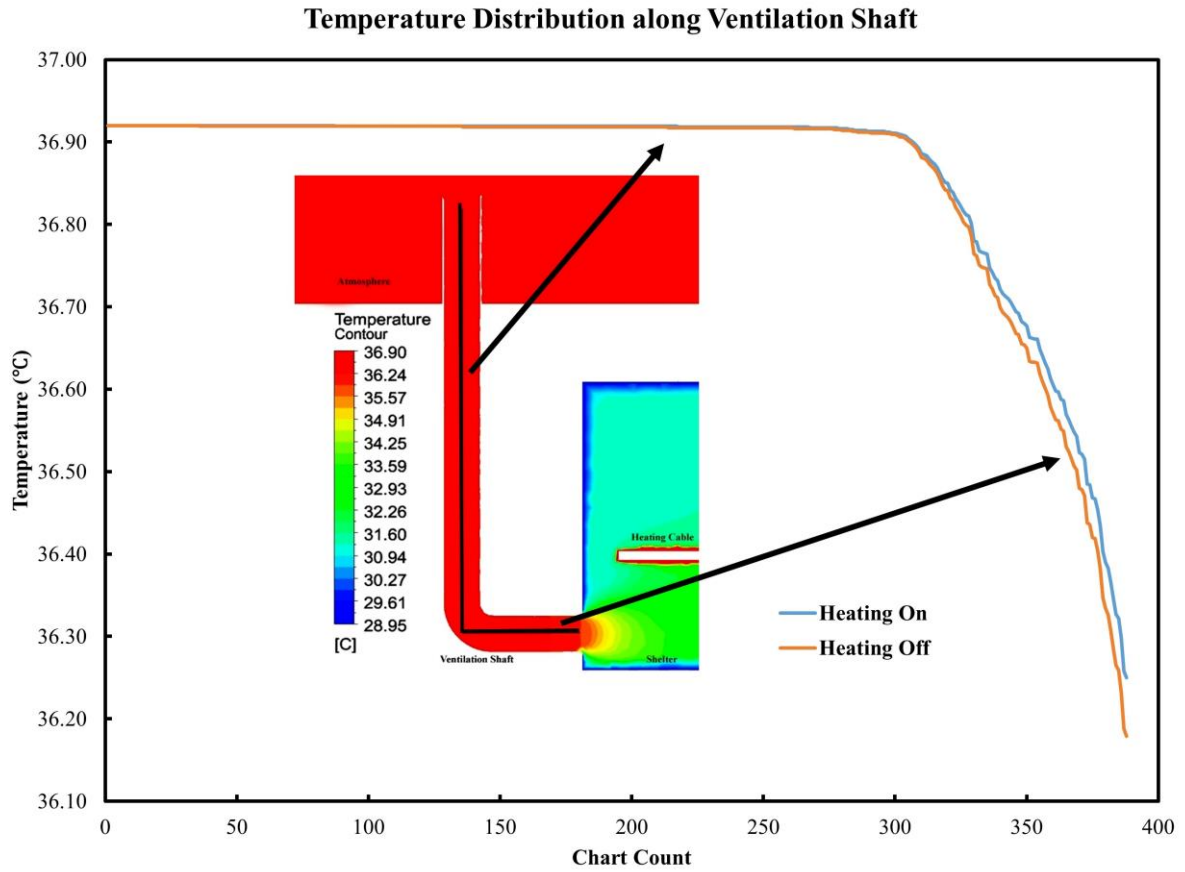

Fig. 8. Temperature Distribution along Ventilation Shaft (daytime)

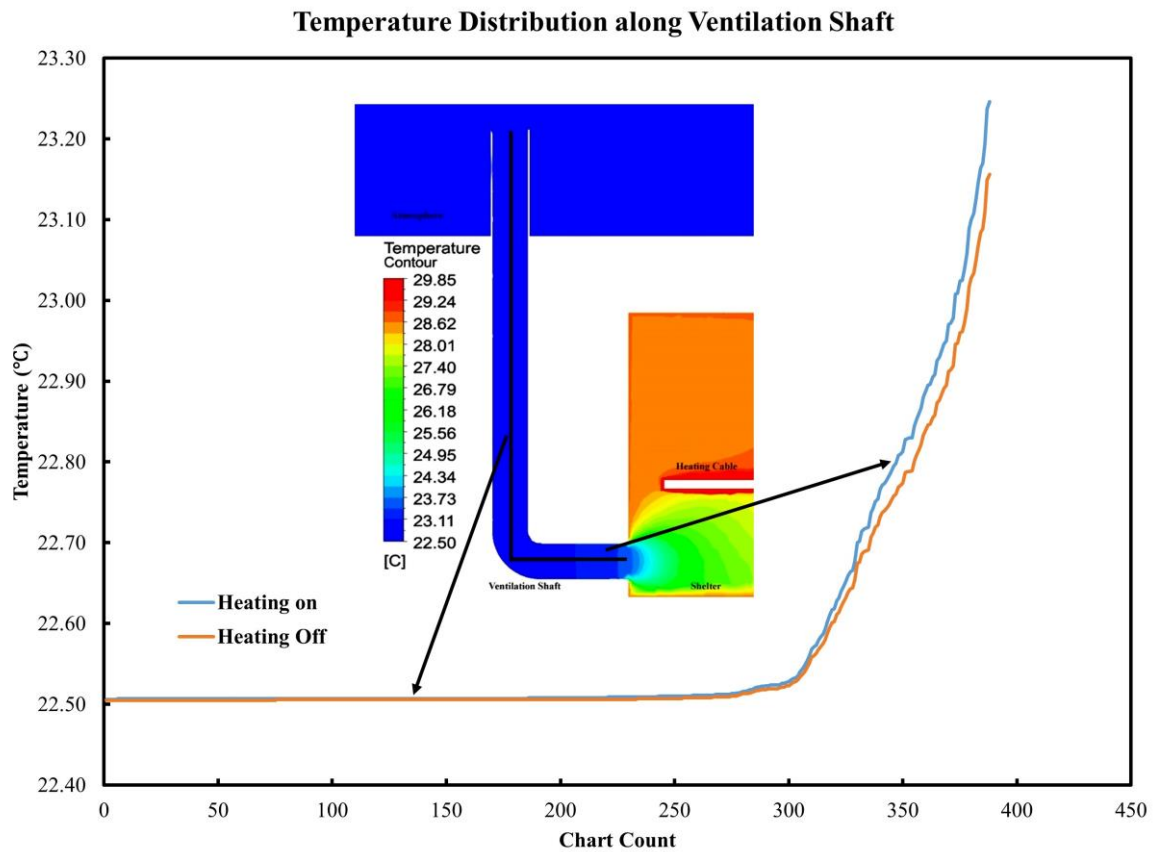

Fig. 9. Temperature Distribution along Ventilation Shaft (night-time)

4.4 Assessment of Comfort Temperature

Based on the discussions in Section 0, even though the soil has absorbed much heat from the indoor environment, the indoor temperature still exceeds the Malaysian comfort temperature (~ 24 - 28°C) [20]. This indicated that the occupant inside the shelter suffered about four units of thermal discomfort during the warmest month of the year. It seems that the use of natural ventilation alone may not be adequate; however, it can be utilised as a supporting system for mechanical devices (for energy reduction). In Section **Error! Reference source not found.** (night time, coldest month), the occupant suffered about one unit of thermal discomfort. As seen, the deviation between day and night thermal discomforts was about three units. It was believed that ventilation during night time could be used to expel the hot air and replace it with the cool night time air.

4.5 Effect of On-ground Wind Speed for Passive Heating/Cooling Operation

In order to assess the effect on-ground wind speed, the data samples collected from the month of March was used for daytime operation and the month of Nov was used for night-time operation. Both data were selected due to the minimum and maximum temperature, which are virtually similar to the assessment of comfort temperature (Section 4.4). Nevertheless, the differentiating factor in both cases is wind speed. According to the data collected in Table 3 and Table 4, there is no substantial change in comfort temperature when the wind speed is varied. In fact, indoor air velocity is one of the determining parameters in local thermal comfort. To the best of the authors' knowledge, in order to control the effect of local thermal comfort, the indoor air velocity should (a) below 0.9 m/s during summer season and (b) above 0.15 m/s during winter season.

Table 3
 Effect of on-ground wind speed during daytime operation

Variables	Heating Cable Activated			Heating Cable Deactivated		
	T_c (°C)	I_s (m/s)	Q (m ³ /s)	T_c (°C)	I_s (m/s)	Q (m ³ /s)
Wind: 5 m/s Temp: 36.9 °C	~31	0.517	0.071	~32.10	0.517	0.071
Wind: 5.5 m/s Temp: 36.6 °C	~31	0.779	0.081	~32.10	0.779	0.081

T_c = comfort temperature, I_s = Indoor Air velocity and Q = Air Flow rate

Table 4
 Effect of on-ground wind speed during night-time operation

Variables	Heating Cable Activated			Heating Cable Deactivated		
	T_c (°C)	I_s (m/s)	Q (m ³ /s)	T_c (°C)	I_s (m/s)	Q (m ³ /s)
Wind: 2.8 m/s Temp: 22.5 °C	~29.20	0.467	0.047	~27.80	0.467	0.047
Wind: 3.1 m/s Temp: 22.8 °C	~29.20	0.482	0.052	~27.80	0.482	0.052

T_c = comfort temperature, I_s = Indoor Air velocity and Q = Air Flow rate

5. Conclusions

In this study, the energy reduction of an underground shelter was investigated by performing CFD assessment on the heating and cooling operations under the Malaysian climate. Initially, the soil temperature was calculated using the Kasuda Model. The results were then applied to analyse the indoor temperature of the underground shelter during the warmest and coldest months of the year.

During the warmest and coldest months, the occupants experienced about four units and one unit of thermal discomfort, respectively. These assessments were performed based on the indoor temperature results. It was found that natural ventilation alone could not assure a good thermal comfort level within the underground shelter. Thus, the other devices or applications (i.e. mechanical system) should be utilized in order to achieve the level of the range for Malaysian comfort.

Acknowledgement

The authors would like to express their gratitude to the Malaysian Meteorological Department for providing the meteorological data. Also, the financial support given by Takasago Research Fund and Pioneer Scientist Incentive Fund (Proj-In-FETBE-038) is greatly acknowledged.

References

- [1] Miloud Hamadache, Moulika Mouli, Bouhamou Nasr-eddine, A.S.Benosman, F. Dif, O.chaib, and Berrabah Hamza Madjid. "Use of Pozzolan Mortars for the Thermal Comfort of Buildings." *Journal of Advanced Research in Materials Science* 34 (2017): 1 – 7.
- [2] M. Morsy, M. Fahmy, H. Abd Elshakour, and A. M. Belal. "Effect of Thermal Insulation on Building Thermal Comfort and Energy Consumption in Egypt", *Journal of Advanced Research in Applied Mechanics* 43 (2018): 8 – 19.
- [3] Van Dronkelaar, C., D. Cóstola, R. A. Mangkuto, and J. L. M. Hensen. "Heating and cooling energy demand in underground buildings: potential for saving in various climates and functions." *Energy and Buildings* 71 (2014): 129-136.
- [4] Al-Temeemi, A. A., and Douglas John Harris. "A guideline for assessing the suitability of earth-sheltered mass-housing in hot-arid climates." *Energy and buildings* 36, no. 3 (2004): 251-260.
- [5] Anselm, Akubue Jidefor. "Earth shelters: A review of energy conservation properties in Earth sheltered housing." *Energy Conservation* 31 (2012): 125-48.
- [6] Porras-Amores, Cesar, Fernando R. Mazarron, Jaime Cid-Falceto, and Ignacio Cañas. "Energy efficient underground construction: natural ventilation during hot periods." In *International Conference on Petroleum and Sustainable Development*, vol. 26. 2011.
- [7] Anselm, Akubue Jidefor. "Passive annual heat storage principles in earth sheltered housing, a supplementary energy saving system in residential housing." *Energy and Buildings* 40, no. 7 (2008): 1214-1219.
- [8] Hazbei, Morteza, Omid Nematollahi, Mohsen Behnia, and Zahra Adib. "Reduction of energy consumption using passive architecture in hot and humid climates." *Tunnelling and Underground Space Technology* 47 (2015): 16-27.
- [9] Moradi, H., and H. Eskandari. "An experimental and numerical investigation of Shovadan heating and cooling operation." *Renewable energy* 48 (2012): 364-368.
- [10] Mukhtar, A., K. C. Ng, and M. Z. Yusoff. "Passive thermal performance prediction and multi-objective optimization of naturally-ventilated underground shelter in Malaysia." *Renewable Energy* 123 (2018): 342-352.
- [11] King, J. C. *Gravity Ventilation of Underground Shelters*. No. NCEL-TR-367. NAVAL CIVIL ENGINEERING LAB PORT HUENEME CA, 1965.
- [12] Dahlan, Nur Dalilah, Phillip John Jones, Donald Kneale Alexander, E. Salleh, and Dylan Dixon. "Field measurement and subjects' votes assessment on thermal comfort in high-rise hostels in Malaysia." *Indoor and Built Environment* 17, no. 4 (2008): 334-345.
- [13] Kusuda, Tamami, and Paul R. Achenbach. *Earth temperature and thermal diffusivity at selected stations in the United States*. No. NBS-8972. National Bureau of Standards Gaithersburg MD, 1965.
- [14] Yusof, T. M., S. Anuar, and H. Ibrahim. "Numerical investigation of ground cooling potential for Malaysian climate." *International Journal of Automotive and Mechanical Engineering* 10 (2014): 2081-90.
- [15] Mukhtar, Azfarizal, M. Z. Yusoff, and K. C. Ng. "An Empirical Estimation of Underground Thermal Performance for Malaysian Climate." In *Journal of Physics: Conference Series*, vol. 949, no. 1, p. 012011. IOP Publishing, 2017.
- [16] Brake, D. J., and G. P. Bates. "Criteria for the design of emergency refuge stations for an underground metal mine." In *AusIMM Proceedings*, vol. 304, no. 2, pp. 1-8. THE AUSTRALIAN INSTITUTE OF MINING AND METALLURGY, 1999.
- [17] Mukhtar, A., K. C. Ng, and M. Z. Yusoff. "Design optimization for ventilation shafts of naturally-ventilated underground shelters for improvement of ventilation rate and thermal comfort." *Renewable Energy* 115 (2018): 183-198.
- [18] Mukhtar, A., K. C. Ng, M. Z. Yusoff and M. F. M. Nasir. "Application of Box-Behnken design with response surface to optimize ventilation system in underground shelter." *Journal of Advanced Research in Fluid Mechanics and Thermal Sciences* 52, no. 2 (2018): 161-173.

-
- [19] Kearny, Cresson H., and Lambert Mims. *Nuclear war survival skills*. Oregon Institute of Science and Medicine, 1987.
- [20] Davis, Mohd Peter, Gregers Peter Reimann, and Mazlin Ghazali. "Reducing urban heat island effect with thermal comfort housing and honeycomb townships." In *Conference on Sustainable Building: South East Asia*. 2005.