



## Low Speed Wind Turbines for Power Generation: A Review

Open  
Access

Sri Ragunath Venkatramakrishnan<sup>1,2</sup>, Jitendra K Pandey<sup>2</sup>, Amit Kumar Mondal<sup>3</sup>, Ashish Karn<sup>1,\*</sup>

<sup>1</sup> Department of Mechanical Engineering, School of Engineering, University of Petroleum and Energy Studies, Energy Acres, Bidholi, Dehradun, Uttarakhand, 248007, India

<sup>2</sup> Department of Research and Development, University of Petroleum and Energy Studies, Energy Acres, Bidholi, Dehradun, Uttarakhand, 248007, India

<sup>3</sup> School of Engineering and Information Technology, Manipal Academy of Higher Education, G04, Dubai International Academic City, Dubai, 345050, UAE

### ARTICLE INFO

#### Article history:

Received 13 August 2019

Received in revised form 10 September 2019

Accepted 12 September 2019

Available online 15 March 2020

### ABSTRACT

Wind turbines are simple and eco-friendly means of generating electricity. This review paper introduces the challenges in harvesting maximum energy at low wind velocities (typically around 3 m/s, the cut-in wind speed for most of the turbines). The recent research works carried out with regards to design and operation of the wind turbines at low wind velocities are summarized. With respect to design, optimizing blade geometry, improving the starting characteristics, addition of flow augmentation devices and electrical efficiency improvement are explained. Regarding the operation of low wind velocity turbines, some novel means of improving the operational performance and some unconventional modes of operation have been discussed thoroughly. The current study on low speed wind turbines has ascertained that there is a great potential for energy harvesting at low wind velocities with significant possible improvement in energy conversion efficiency. Finally, few potential areas of research in the area of low speed wind turbines have been pointed out.

#### Keywords:

Small wind turbines; Low wind regime;

Blade geometry; Flow augmentation;

Operational performance

Copyright © 2020 PENERBIT AKADEMIA BARU - All rights reserved

## 1. Introduction

The development of all the sources of renewable energy generation, including wind, is the need of the hour in fighting against global warming caused by depleting and polluting sources of energy like coal. The renewable energy sources provide clean and sustainable electricity and can propel a nation's economy, which is closely related to its energy generation. These sources aid decentralized energy generation that will benefit the local communities.

Wind energy, one of the most promising sources of renewable energy, is actually derived from solar energy. The generation of wind can be attributed to both global and local effects. On a global scale, wind is created by the pressure difference due to uneven heating of earth's atmosphere by solar radiation. The sun rays cover a much greater area at the equator than at the poles. The hot air

\* Corresponding author.

E-mail address: [akarn@ddn.upes.ac.in](mailto:akarn@ddn.upes.ac.in) (Ashish Karn)

rises from the equator and expands, and the cold air from the poles move towards the equator. The winds blowing towards the equator from north and south poles gets deflected due to the effect of rotation of the earth, also known as Coriolis effect. According to Ferrel's law, winds in the northern hemisphere get deflected to the right of their path and those in the southern hemisphere to their left [1]. This represents the global scale circulation of the wind on the earth surface. In addition, winds are also generated due to local effects like land-sea contrast, mountain winds, valley winds, etc. A wind energy conversion system transforms the kinetic energy available in the wind into mechanical or electrical energy that can be utilized for several applications. For instance, mechanical energy is most commonly used by wind mills for pumping water. On the other hand, wind electric turbines generate electricity that can be utilized locally or transported to the desired location through grid. While the use of wind mills has significantly declined over the years, technological advancements in wind electric turbines continue to grow ever since its evolution.

The evolution of the wind turbines for energy generation dates to the oil shock of the late 1970s that impelled the energy policy planners to explore alternative sources of energy [2]. Among alternate energy sources, wind energy gained much prominence and while initially wind turbines were developed only at research scale, recently with government incentives the technology has seen commercialization, and therefore reached grid parity in many locations [3]. The modern-day wind turbines generate electricity in Mega Watt scale. There is a tremendous growth in power rating of the wind turbines both in terms of hub height and blade diameter as depicted by Figure 1.

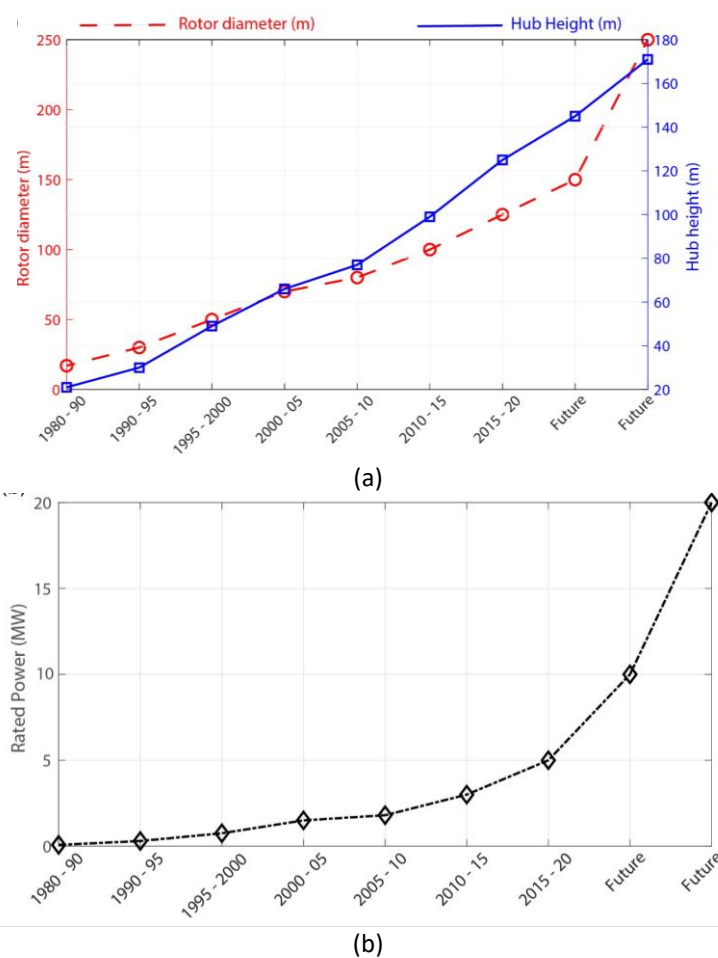

**Fig. 1.** Increase in (a) Rotor diameter and Hub height and, (b) Wind Turbine Capacity over the Years [4]

Figure 1 depicts an increasing trend in power rating of a wind turbine, as a result of increasing rotor diameter and the hub height. This continued growth of single unit capacity of wind turbines resulted in lesser unit cost, greater economy of scales and better space utilization in the wind farm. Nowadays, almost all the countries blessed with wind resources have made wind energy generation an integral part of energy generation mission [5].

International Electrotechnical Commission standard IEC 61400-2 defines small wind turbine as a turbine that has a rotor swept area of less than 200 m<sup>2</sup>, generating approximately 50 KW power at a voltage below 1000 V AC or 1500 V DC [6]. This standard also specifies requirements for the safety of small wind turbines including design, installation, maintenance and operation under specified external conditions. Design of small wind turbines presents its own set of challenges viz. the requirement of starting torque at low wind speeds, withstanding heavy wind speeds, etc. Only residential buildings and few commercial establishments are the main consumers of electricity generated by small wind turbines, due to which mass production of these turbines is difficult, which leads to high cost/ unit produced. There is lack of knowledge among the consumers about the wind resource, turbine and the load, which leads to ineffective utilization of the turbines. Design of commercial wind turbines for generation at low speeds is also being considered as an alternative to small wind turbines. However, a host of parasitic losses involved pose an obstacle to such power production at low speeds. Some of these losses include: Yaw mechanism to turn the rotor to face the wind, pitch mechanism to adjust the blade angle to the wind, lights, controllers, communication, sensors, data collection, etc., oil heater, pump, cooler and filtering system of the gearbox components, hydraulic brake to lock the blades when the wind is heavy, thyristors for power conditioning and connection, magnetizing the stator to maintain constant rotor speed, drivetrain resistance, inverter efficiency etc. At any given time, the above mentioned losses account for around 50% of the power production, making the cut-in wind speed for almost all the commercial turbines somewhere between 3 m/s to 4 m/s. Considering all these limitations, unlike the large wind turbines which are very efficient in harvesting energy at high wind conditions, with efficiencies not very far from the Betz limit, the small wind turbines are quite limited. Clearly, there is a burgeoning interest in improving the performance of the wind turbines in low wind regime [7]. Researchers have carried out experiments to improve the performance of the large wind turbines at low wind velocities and also worked on designing new turbine (small scale) altogether that works only in low wind conditions. National Renewable Energy Laboratory formulated a program for reducing the cost of energy of commercial low wind speed turbines as necessitated by huge potential for the exploitation of low wind speed sites [8]. A study on power generation from low-wind speed GE 1.5-MW series turbine indicated significant power gain in the low windy areas of Minnesota, U.S.A. These turbines were designed to have low cut-in, low rated and low cut-off wind speeds. The increase in power production was found to be more pronounced at higher rotor diameters [9]. In the current review article, we will categorize and examine several such studies pertaining to the improvement of efficiency of wind turbines, both large and small, at low wind speeds.

## 2. Design of Wind Turbines In The Low Wind Velocity Regime

To date, limited research has been carried out in the area of small wind turbines, with very few reported studies in the domain of small wind turbines as pointed out in a prior review article [10]. Prior to the year 2000, the wind industry has focused on the deployment of large wind turbines with a somewhat lesser thrust on the improvement of aerodynamic characteristics of small turbines [11]. Serious impetus to the research on small wind turbines was given post 2000. Researchers have tried to understand and improve the performance of wind turbines under two distinct categories – (a)

Design of Wind Turbine components, (b) Mode of operation of Wind Turbines. The design of wind turbine components has its roots in basic design principles and the serious research activities pertaining to this section were immediately carried out post 2000. Most of the standard design principles that apply to the large wind turbines are also applicable to the small wind turbines with similar mode of operation, making design a relatively easier path to begin with. The second category is relatively new as more novel operational modes of wind turbines to capture energy from low winds have emerged post 2000.

To understand and improve the performance of wind turbines at low wind velocities, atmospheric turbulence, characterized by the winds of changing speed and direction, is yet another factor that has to be understood. Wind turbines operating in highly turbulent environment suffers power losses, and this is primarily the reason for lower power production of wind turbines compared to the power curve given by its manufacturer. The effect of power loss due to turbulence is more pronounced in HAWT compared to VAWT. HAWT begins to slow down when there is a sudden acceleration of wind beyond cut-off wind speed (though for a shorter time period), and yaws when wind changes its direction. Both aspects will increase the load on the control system, thus reducing the actual power generated. VAWT suffers less of this loss due to its omnidirectional wind intake and less sophisticated control system. For this purpose, the wind turbine power curve has to be normalized with respect to the turbulence intensity at the site for better predicting the power output [12]. The effect of turbulence on structural loading of a turbine is also a significant effect to be considered for power generation as well as the safe operation of the turbine. There is a need for re-designing the wind turbine blade according to the turbulence intensity it faces during the operation. A study by Tabrizi *et al.*, [13] reveals that the turbine blade loading is twice as predicted by the standard Kaimel Spectra (which is used to model the performance of wind turbine operating under turbulence). Hence, as emphasized, there is a need to modify the blade design by incorporating changes to the standard Kaimel Spectra. The effect of turbulence becomes even more important in case of small wind turbines and the large wind turbines operating in the low wind environment. Wind turbines designed for low wind speeds can operate profitably only when the turbulence intensities at the site are low. This is evident from the report by Wisser and Bolinger [14], where they reported that the potential energy generation from unexploited low wind speed inland sites in U.S.A. is more as most of these sites are characterized by low levels of atmospheric turbulence. The subsequent sections detail the developments on capturing energy of low winds under both of the broad categories of design and operation.

## 2.1 Design Perspective

### 2.1.1 Aerodynamic performance enhancement by optimizing blade geometry

The real impetus in this direction was given by Duquette and Visser, who has carried out the investigations on the effect of number of blades and blade solidity on the performance of HAWT by using four methods – Blade Element Momentum Theory (With loss correction), BEMF and Blade Element Momentum Theory with Finite Wing Correction), BEMFW, Lifting line based Wake Theory (Non –expanding Rigid Wake Model), RWM and Lifting line based Wake Theory (Expanding Wake Model), EWM [15]. A brief description of these methods and the equations used for computation through all the four methods can be found in the above reference. Validation of the four proposed models was done by comparing the results of these models with two rotors of published experimental data. Subsequently, parametric numerical study was conducted using the four methods on a rotor of radius 1 m and hub radius 0.1 m with SG6043 airfoil throughout the length. All calculations were performed for the free stream wind speed of 8 m/s. The results were calculated

for a 3-bladed and a 12-bladed turbine for a rotor solidity  $\sigma$  of 0.05, 0.15, 0.25 and 0.35. The 12-bladed wind turbine with  $\sigma = 0.25$  yielded maximum power coefficient,  $C_p$  (which is the ratio of generated power and the maximum power contained in the wind). There were no significant difference in values for solidities of 0.25 and 0.35, so optimum solidity was taken to be 0.25. The study found that a little increase in the solidity of the rotor with a greater number of blades of a conventional small HAWT yields significantly high-power coefficients. The torque coefficient of high solidity rotor was exceedingly high, approximately 900% of the torque coefficient of low solidity rotor, aiding easy start up and significantly low cut-in wind speeds. A recent development was incorporating classical BEM theory and Computational Fluid Dynamics (CFD) analysis for design of large scale off shore wind turbines for studying the economic feasibility of the windfarm project successfully [16].

Further investigations under first category were made by Zhang *et al.*, [17] where both design and research of high-performance low speed wind turbine was done. Initially, profiles of low wind speed airfoils S822 at the tip and S823 at the root were taken for further optimization of chord length and blade installation angles at various locations by applying Blade Element Momentum (BEM) theory in a Genetic Algorithm (GA). Then using CFD, design point verification and in-depth analysis were done. Initial design of rotor at design wind speed of 6 m/s with the maximum power co-efficient of 0.397 was done using the Hicks-Henn function in GA to modify the initial design. The objective function of the optimal design was to obtain the largest possible power co-efficient of the rotor at a wind velocity of 6 m/s, and power coefficient of the optimized rotor was obtained at 0.430. Optimized blade required slightly greater chord length at the root compared to original, although the geometry of the rest of the sections were as before. The twist angle for original rotor increased from the root of the blade till 1.5 m and decreased for the later part of the span, but for the optimized rotor the twist angle was a continuously decreasing function. The design points were further analyzed by the CFD software to give the comprehensive information of the flow conditions. Both BEM and CFD results proved that the optimized blade has better aerodynamic performance at low wind speeds compared to the original blade.

Optimization of a fan type 8 bladed micro turbine (radius-117 mm and width 60 mm) was done by Leung *et al.*, by varying blade subtend angle and the blade number by using a developed CFD model [18]. The CFD model was validated with the results of the experiment conducted in a wind tunnel. Then optimization of the wind turbine performance was done by comparing the performances with different blade profiles. The blade subtend angle was varied from  $30^\circ$  to  $110^\circ$ , and for each series blade number was varied from 3 to maximum solidity blade number. The power coefficient in each case was calculated, and it was observed that the high solidity rotors were much more efficient than low solidity 5-bladed rotors. Rotor with  $60^\circ$  blade angle (solidity – 65.3%) yielded optimum power coefficient of 19.3 % for a wider range of wind speeds. This was much higher than the original 8-bladed turbine of  $30^\circ$  blade subtend angle.

It is necessary to have prior knowledge about the range of wind speeds that a wind turbine will encounter at the site. Computer simulations can be performed for these wind speeds at various angles of attack (angle between the line of chord of an airfoil and the relative airflow) using different airfoil sections. The results which give high life-to-drag ratios for wide range of angles of attack can be further studied to get a clear picture of optimal airfoil distribution across the length of the blade. As shown in Figure 2 below, it is not the maximum lift or minimum drag, but maximum lift-to-drag characteristics, that is a single most important parameter for any wind turbine blade design [19].

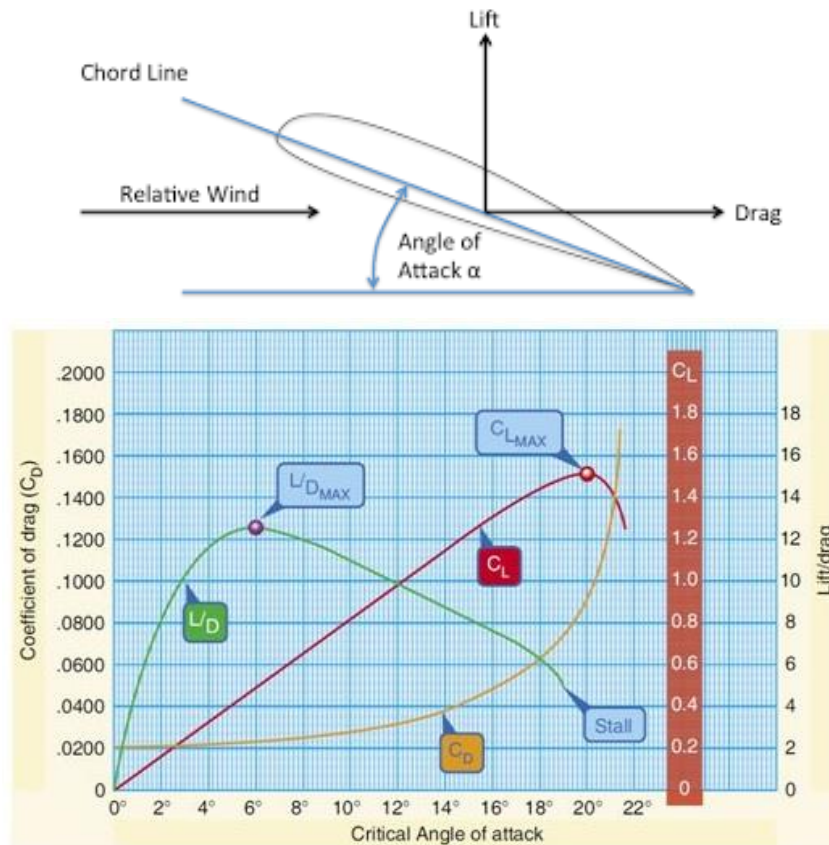

**Fig. 2.** Illustration of Angle of Attack vs Coefficient of Lift ( $C_L$ ), Coefficient of Drag ( $C_D$ ) and Lift to Drag (L/D) ratios of an airfoil [20-21]

Another study concerning modification of angle of attack by modifying the leading edge profile of the blade was conducted recently. The concept is a biomimicry inspired by smooth gliding whales which have humped back. The leading edge was modelled as humped back profile of the whale that performed better compared to regular, smooth leading edge. This study points to the foreseeable future of experimenting such new ideas inspired from nature to improve the performance of wind turbines under low wind conditions [22].

Drop in efficiency due to flow separation is a major issue of low Reynolds Number flow in Small Wind Turbines at low wind speeds. This was addressed by Singh and Ahmed, who compared the performance of a specially designed 2 – bladed rotor with AF300 flat back airfoil, with exponential twist and taper distribution with Air-X 3 bladed, fixed pitch wind turbine rotor [23]. The 2-bladed rotor was fabricated out of wood to have light weight and operate in low wind speeds. AF300 Airfoil achieved high lift at low Reynolds numbers. The turbine was tested in three different pitch angle settings 15°, 18° and 20° with 18° pitch angles giving the best performance. Rotor at 20° pitch angles demonstrated the next best performance and 15° the least, although 15° pitch angle rotor performed better than the three-bladed rotor after 4 m/s wind speed. At 18° pitch setting, average and instantaneous cut-in speeds were 3.24 m/s and 2.34 m/s yielding highest power coefficient of 0.27. In general, the performance of the two-bladed rotor was much better than the Air X rotor.

Very recent researches also focus on the taper distribution of the blades for continually improving its performance. Taper has a significant relationship to rotor thrust and torque [24]. It was reported for increase in torque and reduction in thrust the tip chord values should be kept as small as possible. There is a trade-off between root chord values and mid-span chord values for achieving combined

objectives of increasing torque and reducing thrust, as larger root chord values compared to mid span chord values may lead to reduction in thrust, but they reduce torque generation also. It is also to be noted that appropriate tip loss correction factors should be incorporated in the design, as there is loss of lift at the tip of wind turbine blades due to 3D flow (span wise flow coupled with usual chord wise flow). While there are some standard formulae to calculate tip loss as such Prandtl's tip loss correction, simultaneously empirical models are also being developed based on experiments. Tip loss correction modelling is an active research area in wind energy.

Surface integrity of the blades are very important for maintaining higher power production of wind turbines. Wind power plants are mainly located in Nordic, tropical and arid areas where wind velocities are very high. In Nordic area incidence of ice deposition on wind turbine blades is high. In warm tropical areas there is significant insect population, which may collide with blades and reduce its integrity. In arid areas, blade erosion by dust particles is an area of concern. All these three factors-ice, insects and dust post significant challenges in wind turbine operation [25]. The roughness alters the flow field around blade surface and can cause in significant drop in lift that translates to reduced power generation. Roughness at leading edge is more of a concern than trailing edge roughness, which has negligible effect on wind turbine performance [26]. A sensitivity study of various airfoils to different roughness values has to be made in the design stage to choose the airfoils that are insensitive to roughness variations. An emerging area of research is using nanocomposites as blade materials / coating with blade material to mitigate the effect of roughness on turbine performance.

To sum it up, optimizing the blade geometry is the most effective and widely used method to improve the performance of wind turbines at low velocities, as the performance improvement strategy is incorporated right from the design stage. Airfoils with maximum lift to drag ratios for wide range of angles of attack should be considered for the design. Many designs of wind turbines is expected to be developed just by observing nature , like the one inspired by humped back of the whale to improve the performace of wind turbines in low wind speeds. Taper distribution also plays a role in thrust and torque output of the rotor, and they should be optimally chosen for minimum thrust and maximum torque. Tip loss correction should be incorporated to the model during design phase. Surface integrity of the blades should be maintained for optimal performance.

### *2.1.2 Aerodynamic performance improvement by optimizing starting characteristics*

Wind turbines often have very poor starting characteristics at low wind speed, as the system has to overcome inertia. If energy in the low winds has to be captured, the system should deliver excellent starting performance. Initiation of the work towards improving the starting behaviour of HAWT was done by Wright and Wood [27]. Their analysis proved to be a relatively simple design tool for measuring the low wind speed performance of wind turbines. Starting performance of a 600 W (at 10 m/s wind speed), 3-bladed, 2 m diameter horizontal axis wind turbine with permanent magnet generator was determined by measuring rotor acceleration at 160 instances in a field test and comparing it with acceleration predicted using the average value from interpolated airfoil data and generic equations for lift and drag at high angles of incidence. Predicting the lift and drag using generic equations alone was not accurate as it did not take into account the airfoil profile of the blade sections. Hence, the values predicted by these equations were combined with the values of interpolated airfoil data and the statistical average was used as the final value. The results revealed that the comparison was valid over a large range of wind speeds. This proves to be an accurate methodology to estimate starting lift and drag for many blades, especially if the turbines are to operate in low wind speed area.

Analytical solutions for improving the starting characteristics of wind turbines is often restricted to impractical and simple cases. In real-life operation, there is a need for an improved model to accurately predict and enhance the starting characteristics of wind turbines. A Differential Evolution (DE) model, a numerical model, was used by Clifton-Smith *et al.*, [28]. Adapted from BEM theory, DE could accurately stimulate starting and significantly decrease starting time for small drop in efficiency, when it was applied to a 5 KW wind turbine.

Aerodynamic design and optimization of blades for three wind turbines of 0.5 KW, 0.75 KW and 1 KW were performed by Pourrajabian *et al.*, [29] by including starting time along with the output power in the objective function by Hornby [30] which was implemented through Genetic Algorithm. The aerodynamic torque for the whole blade of SG6043 airfoil was calculated by using Blade Element Momentum theory. The Aerodynamic starting torque from root to tip was modelled using "Generic flat plat expression for lift and drag coefficient at high Angles of attack". The differential equation for tip speed ratio was solved until user specified tip speed ratio of "1" was reached. The objective function was to maximize  $w \frac{C_p}{C_{p,max}} + (1 - w) \frac{t_{s,min}}{t_s}$ , where  $w$ ,  $C_p$  and  $t_s$  refers to the weighting coefficient, coefficient of power and starting time, respectively and the subscript *min* refers to the corresponding minimum values. Results showed that including starting time in the objective function remarkably reduced the starting time although a small compromise in power output had to be made. It was noted that large values of chord and twist at root was important for low speed performance. Including generator resistive torque in tip speed ratio equation proved to be effective as it was found that the generator resistive torque delays the starting time of wind turbine as aerodynamic torque could not overcome the same. It was also found that increasing the number of blades up to 5 improves the starting performance as well as the power output of the turbine, especially 0.5 KW.

Software packages play an important role in optimizing the starting behaviour of wind turbines. For instance, observation and optimization of the starting behaviour of a small HAWT was done by Khan *et al.*, with the combination of three software packages [31]. Firstly, Number of blades, radius at each segment of the blade, angle of attack, tip speed ratio and coefficient of lift were given as input to MATLAB for computing chord length and twist angle at each segment based on BEM theory. Wind turbine was modelled in Pro-E, and a second MATLAB function computed the aerodynamic forces iteratively with the help of wind velocity, chord and twist at each segment. Pro E models were incorporated in ADAMS simulation environment, where the earlier calculated aerodynamic forces were applied on wind turbine blades to determine the starting torque [32]. Simulation results agreed well with the experiments carried out in open environment for same wind speed conditions for various range of wind speeds with the error of just close to 9%. Various wind turbine models with differing blade profiles were simulated in ADAMS and output torque was monitored. After increasing chord length and twist near the hub region, ADAMS gave the result of high starting torque. The optimized wind turbines were installed at select locations and generated good starting torques. Another computer program was developed by Sessarego and Wood [33], where power production, starting time and rotor inertia was incorporated in the objective function through GA. The relationship between rotor inertia and starting time is indispensable to take into account, as less rotor inertia due to less mass of the rotor leads to quicker starting of the rotor. Hence, this model is an improvement of the model developed by Pourrajabian *et al.*, [29].

One of the most important parameters affecting the starting behaviour of small wind turbines is air density. Air pressure varies inversely with increase in altitude above the sea level. This causes air density to also vary inversely according to Ideal Gas Equation [34]. The density variation due to higher altitude is not significant enough to cause major changes in power production at the range of wind velocities that the large wind turbines work. However, the effect of density (altitude) has to be



considered for small wind turbines, especially near cut-in wind velocities for the starting behaviour. Mostly small wind turbines are designed for higher power production in a trade-off for delayed starting time. This design could be detrimental in low wind velocity areas, where the turbine would lie idle for most of the time. Pourrajabian *et al.*, [35] assessed in the performance of a small, horizontal axis wind turbine at four different altitudes other than sea level through a constrained optimization function that finds optimum chord and twist distributions at each section of the blade for maximization of power co-efficient and minimization of starting time. It was observed that the reduction of air density at higher altitudes produced a significant decrease in rotor aerodynamic torque for a constant generator resistive torque, thus delaying the starting time. In addition to the generator resistive torque, frictional resistance due to bearings and brake can have a huge impact especially in starting due to Stribeck effect. Modelling of these resistances in estimating the starting characteristics of a small wind turbine was discussed by Vaz *et al.*, [36]. To overcome the issue of low aerodynamic torque, more weightage was given to starting time in the objective function. Introduction of tip speed ratio as a variable to the objective function proved to be significant for optimizing the starting time.

Starting time of the wind turbines can also be decreased by employing rotor of less inertia (by using less weight of blades). In addition to chord and twist distribution, shell thickness at different sections was also modified in another similar work [37]. At each section of the blade optimum (and reduced) shell thickness was chosen in accordance with maximum allowable stress value at that section computed by beam theory. The starting time decreased by 56% to 70% compared to the solid counterpart. Blade redesign by considering tip speed ratio was instrumental in optimizing the starting time. However, it is to be noted that wind turbines are chosen for a particular type of an electric generator and tip speed ratio has to match the required characteristics of that generator.

The generators (Permanent Magnet generators) can also exclusively affect the starting of the wind turbine. Cogging torque is generated due to magnetic attraction between the permanent magnets of the rotor and the corresponding slots in the stator, even when no current is flowing through the stator windings. The resistive torque is also offered by bearings and the gear box. As a rule of thumb, Wood has estimated that the total resistive torque in the gearbox, bearings and the generators should not be more than 1% of the rated torque to have good starting performance [38].

In general, improving the starting characteristics of a wind turbine may compromise its power coefficient. Although various methods were tried to optimize the starting time in exchange for a little drop in power coefficient, consistent results for extended working of such prototypes is still to be reported. Also, algorithms to improve the starting behaviour without compromising on power coefficient are yet to be formulated. It is to be noted that VAWTs are generally self-starting, and hence not much emphasis is given on starting characteristics of VAWT.

### 2.1.3 Aerodynamic performance improvement by flow augmentation devices

The flow augmentation devices increase the velocity of the air intercepted by the turbine, resulting in higher kinetic energy availability in the wind for conversion. They have been used both for Horizontal Axis Wind Turbines and Vertical Axis Wind Turbine (VAWT) and resulted in marginal to significant increase in power output. Performance improvement of a drag based VAWT at various ranges of wind speeds was carried out by Korprasertsak *et al.*, [39] using a wind booster is shown in Figure 3. Wind boosters are simple guide vanes that direct the wind flow to centre of VAWT, thus aiding wind capture at higher velocity, resulting in higher power production. Vanes also helped in throttling the airflow. The blades of guide vanes were mounted around the rotor because of the omnidirectional wind intake of the VAWT. The upper and lower rings were used to attach the guide

vanes at certain positions around the rotor. The co-efficient of power,  $C_p$  of the rotor maximization was the objective function.  $C_p$  was modelled as a function of number of guide vanes and the leading angle of the guide vanes. CFD simulations were performed both for standalone turbine and for turbine with wind booster for velocities ranging from 1 m/s to 8 m/s. Results revealed that with optimal selection of design variables, the turbine with wind booster yielded high value of  $C_p$  for a wider range of tip speed ratio when compared to standalone turbine owing to higher peak power and overall power generation. The Wind Booster yielded the maximum peak value of  $C_p$  at 4.8% with 8 guide vanes and leading angle of  $55^\circ$ . This work could be further continued with different dimensions of the wind turbine rotor and wind booster for different values of wind speed and the performance can be optimized accordingly.

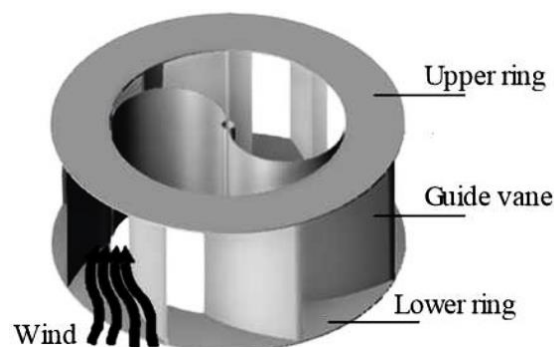

**Fig. 3.** Schematic arrangement of vertical axis wind turbine with wind booster [39]

Kosasih *et al.*, [40] had performed experiments on three configurations of a micro HAWT: Simple diffuser, nozzle-diffuser combination and brimmed diffuser. A three bladed HAWT was tested in a wind tunnel (turbine and tunnel specifications can be found in the reference). The performance was evaluated in the form of Power Coefficient ( $C_p$ ) vs Tip speed ratio ( $\lambda$ ) curve for bare, diffuser and diffuser-nozzle augmented turbine under normal inflow and yawed inflow conditions. The length of the diffuser ( $L$ ) was 120mm with the ratio of length to its inlet diameter ( $D$ ) 0.62. The Expansion angle of the diffuser ( $\alpha$ ) was  $12^\circ$ , just enough to cause sub atmospheric pressure at the exit, which resulted increase in mass flow rate through the diffuser.  $C_p$  increased by 60% with addition of diffuser and 63% with the addition of nozzle-diffuser with the increase in optimum  $\lambda$  being 33% in both the cases. Addition of nozzle with diffuser was significant under yawed inflow condition, when experiments were carried out for  $5^\circ$  yaw angles. Then parametric study of diffuser was carried out by varying  $L$ ,  $D$  (in case of un-brimmed diffuser) and  $L$ ,  $D$  & brim height  $H$  (in case of brimmed diffuser). Figure 4 illustrates the shroud geometrical parameters for easy understanding.

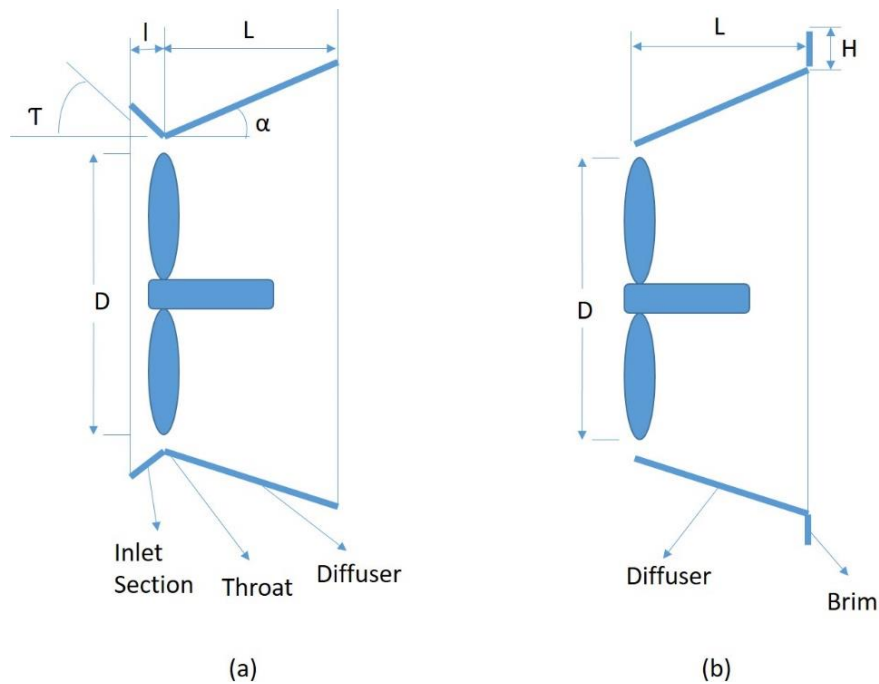

Fig. 4. Typical Design of (a) Nozzle with Diffuser (b) Brimmed Diffuser [40]

The performance curve shifted towards higher  $\lambda$ , whereas optimum  $C_p$  almost remained the same for increase in  $L$ . However, increase in  $H$  increased both  $\lambda$  and  $C_p$ . Increase in  $C_p$  was due to increase in mass flow rate where sub-atmospheric pressure was observed because of the presence of vortices with high kinetic energy. The study concluded that one can optimize the geometric parameters for getting maximum  $C_p$  under different wind speed conditions. Apart from these two major studies, there are many other studies pertaining to flow augmentation devices which are summarized in the Table 1.

**Table 1**

Summary of research works on flow augmentation devices

Reference	Design	Working	Augmentation gain	Type of VAWT/ HAWT
Roy and Saha [39] & Altan and Altigan [41-44]	Curtain Plate Design	Curtain plate placed at the upwind side of the turbine narrow down the air inlet section, which sped up the wind flow	Maximum power coefficient increased about 38.5%, with curtain blade angles of $\alpha = 45^\circ$ and $\beta = 15^\circ$ for the longest curtain blade.	Savonius Wind Turbine
Bhatti <i>et al.</i> , [45]	Convergent nozzle	Nozzle concentrator is placed at the upwind side of the turbine consisting of two plates to flow channel of wind flow to turbine	3.7 times increment in wind speed with the optimal Length of nozzle was 55 cm; with inlet to outlet ratio is 0.15.	Savonius Wind Turbine
Roy and Saha, Bhatti <i>et al.</i> , [46]	V shaped deflector	V shaped deflector is placed upwind at an optimized distance to increase the wind flow	Maximum power increased was 20% with peak $C_p$ at $37^\circ$	Savonius Wind Turbine
Tartuferi <i>et al.</i> , [47]	Self-oriented curtain system	Aerodynamic apendages (termed as deflector and conveyor) which partially encloses the turbine. Incoming wind passes through	Maximum power output increased by 20%.	Savonius Wind Turbine

El-Askary <i>et al.</i> , [48]	Guide deflector design	the concave side and leaves the rear side in a better way; so that the contact angle of blades increases with wind. Both the conveyor and deflector are connected to hinges, which enable them to self-align easily. Different deflector plate designs were tested for optimization with the common working mechanism where the wind is directed towards the concave side. Other two plates prevent the negative torque created on the returning side of the wind.	Maximum power coefficient is 0.52 at TSR of 1.1 which increased by 1.6 times.	
Irabu and Roy [49]	Guide box tunnel (GBT)	GBT's design consist of inlet movable front wall and a diverging movable exit wall for controlling the wind flow.	Maximum output power coefficients are 1.23 (2-blade rotor) and 1.5 (3-blade rotor) times. Maximum output power is 1.08 (2-blades) times higher.	Savonius Wind Turbine
Muller <i>et al.</i> , [50]	Energy Converter Design	It consists of square block with a channel, which is blocked by a moving plate. Due to the stagnation pressure at upstream and downstream of wind flow and flow separation at sharp corner of downstream creates a pressure drop.	Scaled model achieved an efficiency of 40%, with rotor performance of 48% conservatively and 61% optimistically.	Drag Type Sistan Vertical Axis
Chong <i>et al.</i> , [51-52]	Power Augmented guided vane	Vanes creates multiple flow channels by creating venture effect, when wind enters through narrower space and later guided for optimum angle of attack.	Power output increased by 5.8 times with rotor speed improvement by 73.2% at a wind speed of 3 m/s. Also, the self-start wind speed is lowered from 3 m/s to 1.5 m/s.	Sistan Wind turbine
Kin and Gharib [53-54]	Straight plate deflector	Flat deflector is placed at the upstream side of the counter rotating wind turbine to increase the local wind speed performance around the turbine.	Maximum power coefficient was increased by 3 times, while the TSR was also increased from 0.98 to 1.23	Lift type counter rotating VAWT
Santoli <i>et al.</i> , [55]	Convergent Duct	Using venture effect on a convergent duct is used to run the VAWT.	Power increased is 125%, while increase in wind speed is about 30%	VAWT
Pope <i>et al.</i> , [56-57]	Zephyr	Stator vanes are used to reduce the turbulence and redirect the wind towards rotor.	Maximum power coefficient increased from 0.098 to 0.12.	VAWT
Yao <i>et al.</i> , [58]	Baffle plate cowling tower	VAWT is placed inside a cylindrical space called cowling which is surrounded by baffles, which helps in regulating the wind and also reduces the negative torque.	Maximum power coefficient is of 0.48, which is 2.4 times without the arrangement.	Drag type VAWT
Chen and Chen [59]	Vortical Stator Assembly (VSA)	VSA design comprises of loop plates at top and bottom with six half-tube blades to improve the	Improvement of rotational speed, torque output and maximum	Drag type VAWT

		drag-type VAWT. Half-tube vanes act as guided vanes to guide the wind tangentially and create a vertical flow to increase the wind speed.	power by 318%, 200% and 910% respectively at 6 m/s.	
Burlando <i>et al.</i> , [60]	Airfoil Shaped Stator	Enhances wind convergence through the gaps between the stator.	Enhancement of wind flow by 10%.	Drag type Savonius VAWT
Wang and Zhan [60-61]	Lotus shape design	Turbine resembles lotus shape and comprised of semi-circular blades where the rotor resembles petals and static guide vanes are similar to the sepals of lotus flower.	Improved maximum power coefficient is 118%.	Drag type
Chong <i>et al.</i> , [63]	Omni direction guide vane (ODGV)	ODGV is constructed as four side walled with duct around the VAWT. It speeds up and guides the wind to the VAWT blade and also helps in self-start. It also suppresses the negative torque and deals with turbulence.	Rotational speed of turbine increased by 182% and output power enhanced by 3.48 times.	Lift-type H-rotor VAWT
Nobile <i>et al.</i> , [64]	Omnidirectional Stator	Improvised version of ODGV (mention above), where the ducts are having conical surfaces. Design helps in converging the upstream and diverging the downstream.	With the TSR of 2,75, average $C_p$ and $C_T$ was increased by 30- 35%	H-rotor VAWT
Loganathan <i>et al.</i> , [65]	Cowling	Cowling encloses the turbine with concave design, which pushed the wind flow to go out from a small clearance at the upward section.	Rotational speed of rotor increased by 26% (16 blade) and 40% (8 blade).	VAWT
Ali <i>et al.</i> , [66] and Alam <i>et al.</i> , [67]	Cowling	Cowling system comprises of vent tube, to allow inlet wind and a chimney at the center for exhaust of wind. Further, the conical tail helps in aligning with the wind direction.	Rotor speed increased significantly.	VAWT

In summary, the flow augmentation devices have proved to yield significantly better performance at starting wind speeds, but it comes at the cost of less power extraction capability at higher wind speeds. Further, these devices make the system complex in a wind farm by generating wide wake and strong vortex behind the turbine. Adding to that, detailed cost benefit analysis is not reported in the literature.

## 2.2 Operational Perspective

For a given design of a wind turbine, its efficiency could be enhanced by changing its mode of operation and by incorporating some algorithms that enable tracking maximum power at a given wind velocity. The research works pertaining to this category are discussed in this section.

Variable speed operation of wind turbines enables them to be efficient over wide range of wind speeds. A wind turbine operation could be tailored to be more energy efficient at low wind speeds and less efficient at speeds beyond the stall of the turbine. Instead of relying on anemometers for

measurement, the wind turbines themselves can be used as measurement devices for wind speeds. In this study, dead-beat control strategy was adopted where the rotor speed was controlled to make it follow the wind speed closely to generate power efficiently at low wind speeds. A team of Wind Energy consultants supported by National Renewable Energy Laboratory worked on a project where advanced controls were used to reduce the blade loads by extending the blade length to capture more energy [68]. Based on Rotor azimuth position, rotor speed and angle of attack, a state space control system controlled each blade independently, as each blade experiences different loads, according to a weighing function that optimizes the power output and load reduction throughout the system. The blades were stretched only lengthwise to avoid structure weight increase, and also the fact that there would be no significant change in aerodynamic power coefficient when stretched in all dimensions. Variable speed operation was followed between cut-in wind speed and rated wind speed for achieving maximum efficiency. In the region between rated speed and cut-out speed, blade pitch was varied independently to maintain constant rotor speed to minimize blade flapping motion and reduce the turbine loads. Generator torque was maintained constant and rotor torque was varied in response to changes in rotor power. The advantages with this system were smart loads control, reduced structural loads, lengthy blades and more rotor area for low wind speed sites. The disadvantages were complex controller design and tuning and reduced failure tolerance. When applied to baseline 1.5 MW wind turbine, advanced angle of attack independent blade pitch control was able to reduce various structural loads between 5% and 30%, accommodate a 10% blade extension, and provide a net cost of energy reduction of 6.3%. Pitching blades is a very costly affair, especially for a low capacity HAWT and VAWT. Studies are being conducted on promising alternative strategies like passive blade morphing (changing the morphology of the blades as part of flexible wind energy conversion device). In one such study this strategy was employed to both HAWT and VAWT rotor, and the results were compared for rigid and flexible rotors for same set of operating conditions [69]. For HAWT, change in local angle of attack for flexible rotor resulted in increased lift, decreased drag and delayed stall. For VAWT, efficiency improvement was achieved by increased value of minimum rotor torque by passive deflection of blades.

Maximum Power Point Tracking (MPPT) techniques find their role in maximizing the energy conversion from any energy generating system. One of such techniques was used by Koutroulis *et al.*, [70] for a wind turbine – generator system consisting of highly efficient dc-dc buck converter and microcontroller unit. Due to bell shaped nature of power output ( $P$ ) vs rotor angular velocity ( $\Omega$ ), MPPT has to track the point where  $dP/d\Omega = 0$ . As angular velocity is fast changing, accurate measurement of the same is not possible, therefore duty cycle of the DC-DC converter ( $D$ ) was varied, by varying load resistance, for each time step so that maximum power output can be obtained in that instance. By applying chain rule of differentiation, it was proved that  $dP/d\Omega = 0$  simply translated to  $dP/dD = 0$ . The ease of this technique is that measuring power output is easy as this quantity varies relatively slowly. The control could also be extended to other types of converters like Boost converter, Buck Boost converter, Cuk converter and Flyback converter. MPPT operation facilitated variable speed operation of the system, thus reducing the stresses on the generator. Better exploitation of wind energy was achieved, especially under low wind speeds of 2.5 m/s – 4.5 m/s, and the increase in overall efficiency was 11% - 50 % when compared with a system directly connected to a battery bank via a rectifier. An effective way to implement power point tracking is by monitoring the value of Tip Speed Ratio (Ratio of tangential speed of the tip of the blade to the actual speed of the wind). Power coefficient is a function of TSR, and a particular value of TSR corresponds to maximum value of power coefficient.

In another novel mode of operation, fabrication and testing of a combination of Savonius rotor and Darrieus rotor – both Vertical Axis Wind Turbines was done by Letcher [71]. The assembly was

mounted on the same axis in such a way that Savonius rotor was able to start quickly at low wind speeds and generated torque sufficient enough to drive Darrieus rotor. Figure 5 shown the Savonius and darrieus combined model mounted on test stand. A two-stage overlapping between the buckets of Savonius rotor was given to permit the airflow between them and to have optimum efficiency. The buckets were offset, and hence the wind intake was omnidirectional. Three blades profiles were used for three bladed Darrieus rotor – NACA 0012, NACA 0015 and S2027. The assembly was tested in a sub-sonic wind tunnel. The ability to get self-started was more in all the cases except NACA 0012, NACA 0015 with 6" chord length. Turbines started at 5 mph or less. The configuration that produced highest energy was S2027 blade profile, 4.5" chord length,  $0^{\circ}$  pitch angle and 12" Darrieus diameter.

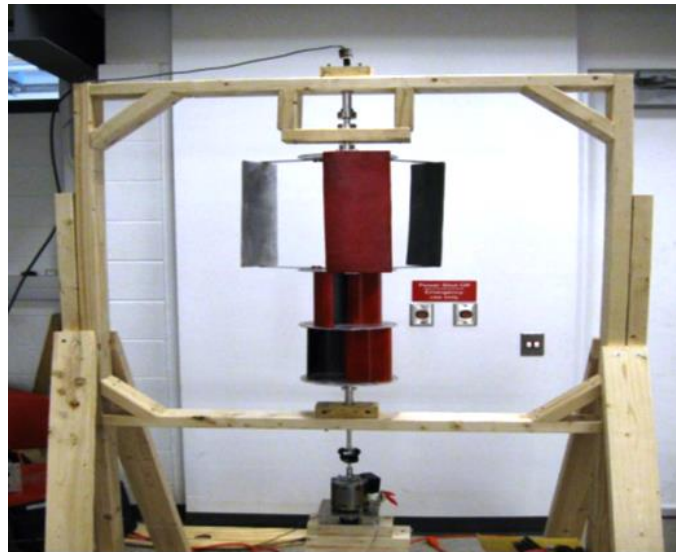

**Fig. 5.** Savonius and darrieus combined model mounted on test stand [71]

This system could prove to be an attractive alternative to constructing power lines to a remote location or having to provide liquid fuel for a generator. This wind turbine design, in conjunction with a battery pack, could provide enough power for the location. FESTO Inc. developed an innovative product called "Dual Wing Generator", where the specialized wind turbine uses reverse principle of natural beating of wings to generate the lift force [72] as shown in Figure 6. It harnesses kinetic energy from the wind, generates linear lifting movement which is later converted into rotary movement and fed to generator for generating electricity. The setup had a central column with a pair of wings on both the column. When air flows, column turned automatically and directed the wings perpendicular to the incoming wind. Motion of the slides created opposing movement of the wings, transferred to bearing shaft through a timing belt. Rotary movement of the shaft were rectified by the free wheels and transferred to the generator through another timing belt.

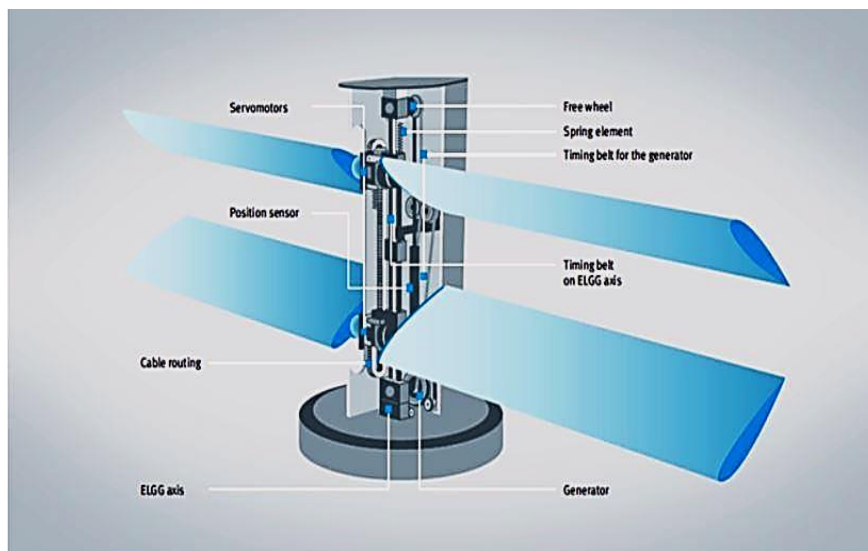

**Fig. 6.** FESTO dual wing generator [72]

The system had double the area of contact of wings with the air though the static mechanical friction remains the same. The dynamic parameters that were independently controlled were maximum angle of incidence, time for triggering rotation and setting. Stiffness of the preloaded springs was set already. Particle Image Velocimetry technique was used to measure the speed distribution on and between the aerofoils over the course of time [73]. Aerodynamic and mechanical efficiencies were determined and compared with conventional turbines of the same size. The system demonstrated excellent starting characteristics and a very high efficiency of 45 % especially in low wind speeds (4 m/s – 8 m/s range).

Computational and experimental study on a new patented technology INVELOX wind turbine (Figure 7) was performed by Allaei and Andreopoulos [74]. The topmost portion of this system was a funnel that captured the wind from all the directions and channelled it downwards into tapering passageway. The inlet cone could also be fitted with fins at desired angle to the wind flow to aid maximum wind capture. Wind was again concentrated before it entered the venturi, where wind energy conversion system was placed. Then the air was allowed to expand in the diffuser before letting into atmosphere. Computational Modelling of the system was done in both ANSYS and COMSOL [75]. The initial and boundary conditions, and the dimensions of the INVELOX system can be found in the reference work. It was observed that adding fins, irrespective of their orientation, captures more wind than the system without fins. Average venturi velocity and the maximum venturi velocity was found to be 10.6 m/s and 12.1 m/s respectively for ANSYS model, and 11.7 m/s and 13.1 m/s respectively for COMSOL model. Average speed ratio of 1.58 and maximum of 1.8 was observed for ANSYS model, and the values 1.74 and 1.95 respectively were observed for COMSOL model.

Subsequently, experimental study was carried out for two cases (i) INVELOX without turbine and (ii) INVELOX with turbine. Wind speed was measured at appropriate locations of the system. For case (i) the field data was scaled based on constant free stream velocity of 6.7 m/s, as given for computational model. The speed ratio varied from 1.5 to 2.1 with an average value of about 1.8. The results were in good agreement with computational models. In case (ii) measurements were taken with turbine inside venture of INVELOX and the results were compared with traditional tower turbine operating at the same location, where the data set was collected for 8 days .It was found that the energy production estimation was 81% to 560% more for INVELOX system than the traditional tower turbines, with average improvement of 314%.



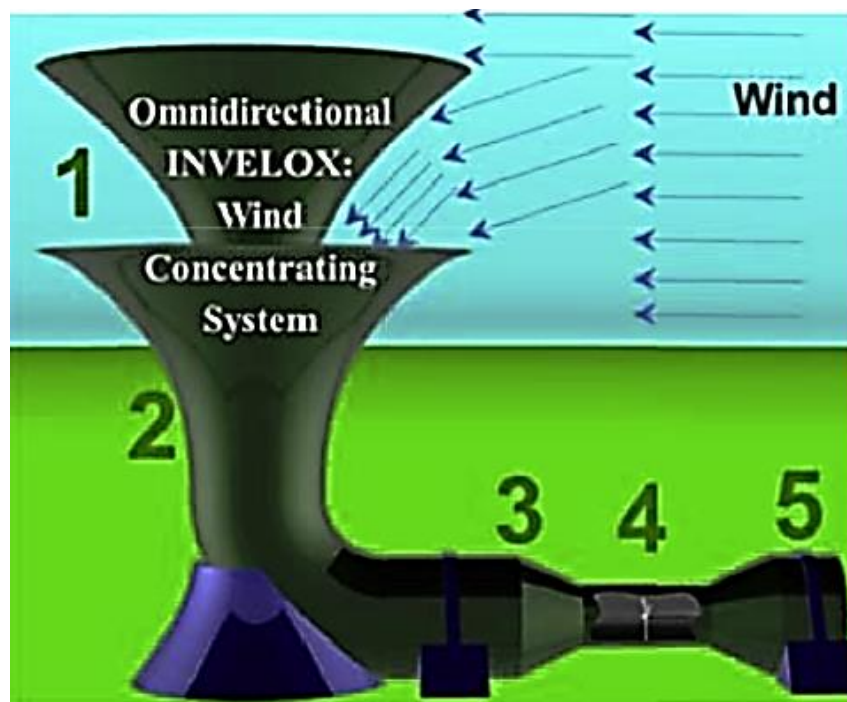

**Fig. 7.** Schematic of invelox system with its components – (1) intake, (2) channelling wind, (3) wind concentrator, (4) venturi with wind energy conversion system, (5) diffuser [74]

It was concluded that the speed ratio could be designed at will since the intake and power production were at different locations. High speed ratio lead to lower area at venture, in turn lower turbine area thus reducing material cost. The turbine of small diameter turned faster eliminating the need of gear box for stepping up the speed to generator speed. The cut-in velocity was much lower which resulted in energy capture even at low winds. The omnidirectional wind intake feature eliminated the need for yaw mechanism.

Further studies were conducted by placing multiple turbine generators in the venture [76]. It was observed that placing 2 and 3 turbines increased power output over a single turbine by 52% and 72% respectively, as well as increase beyond three turbines turned out to be cost-ineffective due to non-linear nature of power increase with the increase in number of turbines. It was also observed that the addition of more turbines did not affect the performance of first turbine, as flow resistance through the system remained unchanged.

Energy harvesting from very low wind speeds for powering wireless sensor nodes using piezoelectric topology, based on piezo-electric effect was attempted by Rezaei-Hossebabadi *et al.*, [77-78]. The setup consisted of a small fan with Permanent Magnets (PM) and Piezoelectric beams with PM Proof mass as shown in Figure 8. Horizontal Axis turbine had even number of PMs with opposite polarities embedded inside the hub, which interacted with PMs at the tip of the Piezoelectric beam. Each beam was surrounded by a frame to protect itself from the direct wind flow.

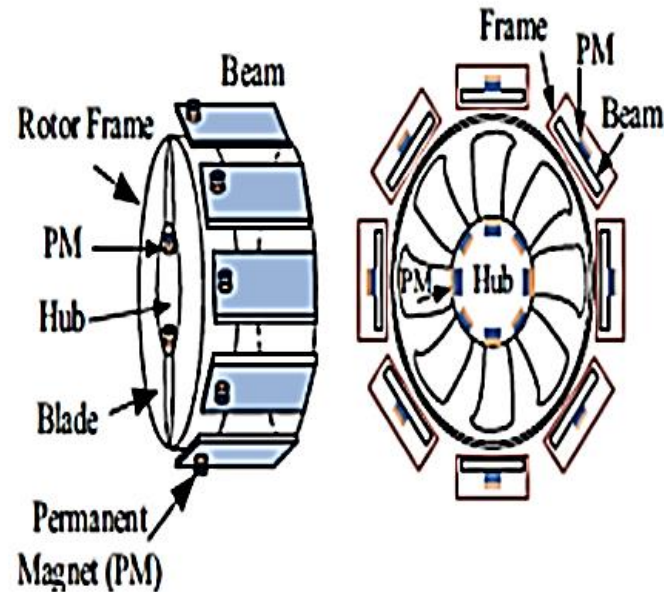
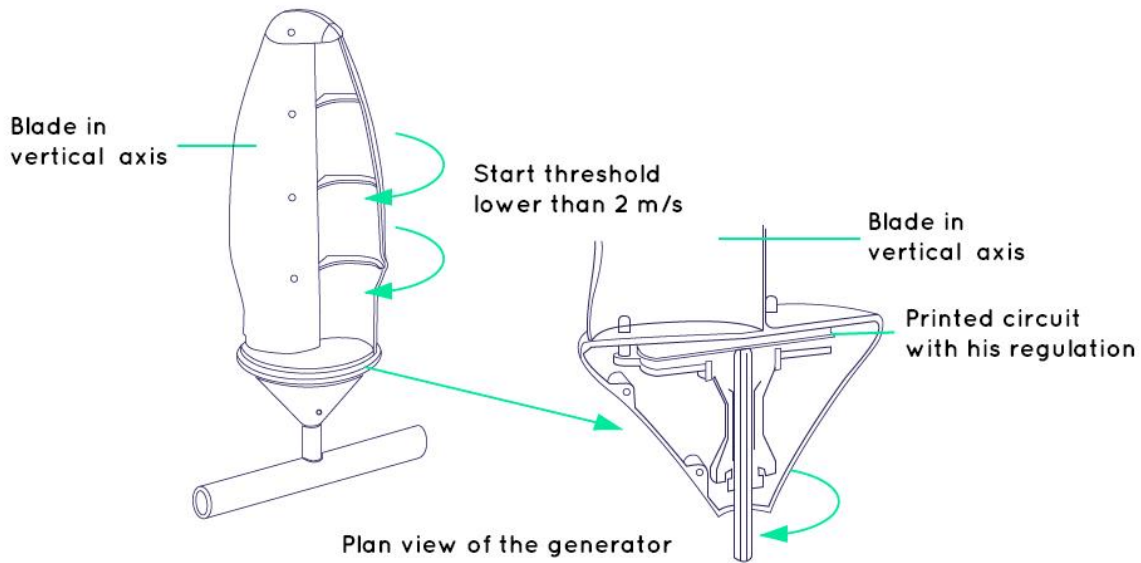

Fig. 8. Horizontal axis wind turbine with piezoelectric beam [77-78]

Irrespective of rotational speed of the fan, the applied sinusoidal force at the beam had constant amplitude, thus generated the power at high voltages even at low wind speeds. The cylindrical arrangement of the beam increased the power density due to more active material. An analytical model was proposed based on the magnetic forces exerted on the beam, whereas a design procedure was presented based on this model to determine the number of PMs to capture the maximum wind power. Effect of beam location on starting torque of the fan was investigated to determine the best arrangement of the beams for minimum cut-in speed. In experimental investigations it was found that the optimum number of PM in hub ( $N$ ) was 4 out of 2, 4 and 6 combinations that were tested along with the number of PM at beam tip ( $M$ ) to be 6. At 4 or more number of magnets in the hub the force generated at the beam was sinusoidal, and as a result of adverse effect of number of magnets on cut-in speed, 4 magnets were chosen. At  $N=4$ ,  $M=6$  open circuit voltage of 10.15V and maximum power output of 363  $\mu$ W was generated. The topology proposed in this work had salient features like high voltage power output (especially at low wind speeds), and also robust structure for high wind speed.

Another innovative development is a product "Aero Leaf" by New wind Inc [79]. The entire system was designed like a tree with small vertical axis wind turbine generators analogous to the leaves of the tree. The leaves were made of light materials that can start rotating even at the slightest waft of air. Each leaf had electronic control system that captured maximum power at all the wind speeds. The activation threshold for this system was close to wind speed of 1.5 m/s, while that of traditional turbines in general is more than 3 m/s. Power generation was reported even at a low wind speed of 2 m/s. The patented device had a capacity rating of 4.1 KW (in fact it can be scaled up using a greater number of leaves) with 63 Aero leaves. The diameter of the tree was 8 m with maximum height of 10m as indicated by Figure 9. The prototype machines were installed at Paris during 2015 UN Climate Change Conference.



**Fig. 9.** Aero Leaf and its operational mechanism [79]

Another novel wind turbine called Wind Beam was developed and patented by Zephyr Energy Corporation [80]. The system has a beam held in between upper and lower springs. The beam has a magnet at its bottom, which enters the coil cavity whenever the beam vibrates. The interaction of magnet with coil generates electrical energy. The entire system is supported by a frame. The constructional features of the system can be seen in Figure 10. The beam has a non-circular airfoil cross section, and when exposed to wind flow over a critical velocity, creates a lifting movement. The transverse vibration of the beam is limited by spring stiffness and frame height. The formation of vortices behind the beam also creates lifting force resulting in vibration of the beam.

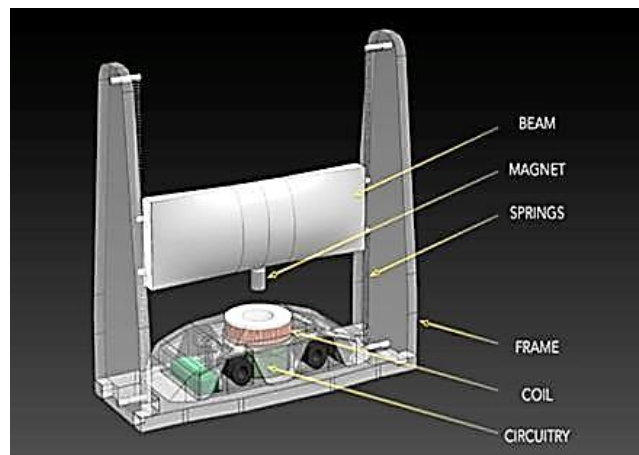

**Fig. 10.** Constructional Features of Wind Beam [80]

This system could be used for small power requiring applications like charging a mobile phone, activating a sensor, etc. The power generation was observed with the wind speed as low as 0.8 m/s. Absence of bearings and gear renders the system very effective with noiseless operation. In one of the research works, wind beam of 4.8" length and 1.25" diameter was tested for HVAC sensor actuation application at wind velocities ranging from 6 mph to 9 mph with power output from 1.62 mW to 5.94 mW.

A first of its kind, bladeless electrostatic Wind Energy Converter EWICON was developed by a Dutch architecture firm Mecanoo architen for Delft University of Technology [81]. The system consists of series of horizontally placed tubes in a frame where each tube contains electrodes and nozzles. Nozzle releases positively charged water particles, which are blown away by the wind. As the system continually loses positive charge, it becomes more negatively charged which sets up an electric field for power generation. This system and the working principle are depicted in Figure 11.



(a)

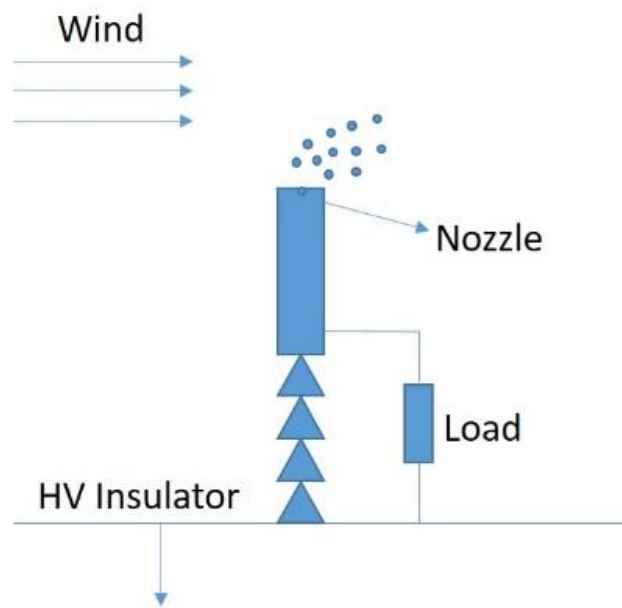

(b)

**Fig. 11.** (a) An image of the EWICON System and the (b) Working Principle [82]

The power generated depends on the wind velocity, size and charge of the water droplets and the strength of electric field. Another prototype had been placed at the top of a building in Rotterdam. The researchers are now experiment the scalability of the device.

### 3. Conclusions and Discussion

The technology for commercial wind turbines at high wind velocities have become sufficiently advanced, thereby prompting researchers to focus on small wind turbines and wind turbines at low wind velocities. There are aerodynamic and operational challenges coming in the way for the development of this segment of turbines. Several research groups have tried to address this by improving design features and by novel operational methods.

Higher blade solidity (close to 0.25) with a greater number of blades, appropriate selection of airfoils across blade length, optimization of pitch angle, twist and taper distribution yielded significantly higher power coefficients in a wide range of wind speeds. Single most important parameter for any successful wind turbine blade design is lifted to drag ratio for various angles of attack. Tip loss correction should be appropriately incorporated, and efforts should be taken for mitigation of roughness effects on turbine performance.

Prediction of the rotor acceleration could be done using the combination of lift and drag equation and interpolated airfoil data, which could be used for optimization of wind turbines at low wind speeds. Addition of starting time along with Power Coefficient in the objective function can prove helpful to improve the starting characteristics of HAWT. Effect of air density on starting characteristics is very pronounced in small wind turbines, and it should be considered while operation. Use of Multi Body Dynamics software such as ADAMS have helped in calculating the rotor starting torque and optimization could be performed by modifying blade geometry. Employing rotor of less inertia and reducing the resistive torque of gearbox and generator will significantly reduce the starting time.

Incorporation of flow augmentation devices like wind boosters for VAWT and a combination of shroud and nozzle for HAWT is helpful in reducing the cut-in wind velocity, however at the expense of power extraction capability at high wind speeds. Further, these devices make the system complex in a wind farm by generating wide wake and strong vortex behind the turbine. Adding to that, detailed cost benefit analysis is not reported in the literature.

Marginal extension of blade length by suitable controls could be employed to enhance more wind capture. Maximum power point tracking using improved algorithms will result in high efficiency of wind turbines in wide range of wind speeds. Novel methods of operation like combining Savonius rotor with Darrieus rotor, flapping blade mechanism in FESTO Dual Wind Generator, omnidirectional wind intake and wind channelling in INVELOX turbine, Piezo electric wind energy converter, tree like wind turbine Aero Leaf, transverse vibrational wind energy converter Wind Beam, bladeless and electrostatic wind energy converter EWICON have been tested and proven successful at lab scale.

Prior research in the area of low speed wind turbines has ascertained and shown that there is a great potential for energy harvesting at low wind velocities with significant possible improvement in energy conversion efficiency. Further studies should aim at enhancing the scalability and cost-effectiveness of the turbines operating in the low wind regime. These two aspects are particularly relevant in the context of competing with solar Photovoltaic (PV) systems globally, where the scalability of PV systems have been demonstrated and cost of PV system components are on continuous decline [83]. Exploiting energy from low velocity winds can serve as a complement to large scale renewable energy systems in fighting against the problem of climate change.

### References

- [1] Mosetti F. (1982). *Forced waves. In: Beaches and Coastal Geology*. Encyclopedia of Earth Science. Springer, Boston, MA
- [2] Sangroya, Deepak, and Jogendra Kumar Nayak. "Development of wind energy in India." *International Journal of Renewable Energy Research (IJRER)* 5, no. 1 (2015): 1-13.

- [3] Vanhanen, J. (2013). *Making Wind Even More Cost Competitive – An Examination of Wind Turbine Costs through Alternatives and a Total Life Cycle Approach*. Wind Systems, March.
- [4] Zayas, J. (2014). *Wind Overview*. Sandia's Wind Turbine Blade Workshop, Albuquerque, August.
- [5] Liu, Zhenya. *Global energy interconnection*. Academic Press, 2015.
- [6] IEC. (2014). *IEC 61400-2 Wind Turbines - Part2: Small Wind Turbines*, CENELEC, Geneva, Canton of Geneva, Switzerland.
- [7] Kjeld, P.V. *Betz' Law*, Chrono Press., 2012.
- [8] Schreck, Scott, and A. Laxson. *Low wind speed technologies annual turbine technology update (attu) process for land-based, utility-class technologies*. No. NREL/TP-500-37505. National Renewable Energy Lab., Golden, CO (US), 2005.
- [9] Wichser, Corinne, and Katherine Klink. "Low wind speed turbines and wind power potential in Minnesota, USA." *Renewable Energy* 33, no. 8 (2008): 1749-1758.
- [10] Clausen, P., and Wood, D. "Research and Development Issues for Small Wind Turbines", *Renewable Energy* 16, no. 1-4 (1999): 922-927.
- [11] Ackermann, T., and Soder, L. "Wind Energy Technology and Current Status: A Review." *Renewable and Sustainable Energy Reviews* 4, no. 4 (2000): 315-374.
- [12] Pagnini, L. C., Burlando, M., and Repetto, M. P. "Experimental Power Curve of Small-Size Wind Turbines in Turbulent Urban Environment." *Applied Energy* 154, (2015):112-121.
- [13] Tabrizi, A. B., Whale, J., Lyons, T., Urmee, T., and Peinke, J. "Modelling the Structural Loading of a Small Wind Turbine at a Highly Turbulent Site via Modifications to the Kaimal Turbulence Spectra." *Renewable Energy*, 105, (2017): 288-300.
- [14] Wisner and Bolinger. *Wind Technologies Market Report 2015*, U.S. Department of Energy, August 2016.
- [15] Duquette, M.M., and Visser, K.D. "Numerical Implications of Solidity and Blade Number on Rotor Performance of Horizontal Axis Wind Turbines." *Journal of Solar Energy Engineering* 125, no. 4 (2003): 425-432.
- [16] Pichitkul, A., and L.A. Sankar. "Aerodynamic Design and Modelling of Large-Scale Offshore Wind Turbines." *CFD Letters* 11, no. 10 (2019): 1-14.
- [17] Zhang, Jialin, Zhenggui Zhou, and Yansheng Lei. "Design and research of high-performance low-speed wind turbine blades." In *2009 World Non-Grid-Connected Wind Power and Energy Conference*, pp. 1-5. IEEE, 2009.
- [18] Leung, D. Y. C., Y. Deng, and M. K. H. Leung. "Design optimization of a cost-effective micro wind turbine." In *Proceedings of the World Congress on Engineering*, vol. 2, pp. 2078-0958. 2010.
- [19] Ribeiro, A. F. P., A. M. Awruch, and H. M. Gomes. "An airfoil optimization technique for wind turbines." *Applied Mathematical Modelling* 36, no. 10 (2012): 4898-4907.
- [20] AVIATIOCHIEF.COM, "Angle of Attack," 2018, <http://www.aviationchief.com/angle-of-attack.html>
- [21] SlidePlayer (2019), <https://slideplayer.com/slide/5870662/>
- [22] Kunya, B.I., C.O. Folayan., G.Y. Pam., F.O. Anafi and N.M. Muhammad. "Performance Study of Whale-Inspired Wind Turbine Blade at Low Wind Speed Using Numerical Method." *CFD Letters* 11, no. 7 (2019): 11-25.
- [23] Singh, Ronit K., and M. Rafiuddin Ahmed. "Blade design and performance testing of a small wind turbine rotor for low wind speed applications." *Renewable Energy* 50 (2013): 812-819.
- [24] Kaya, Mustafa, and Munir Elfarra. "Effect of taper modification on the performance of NREL VI wind turbine blade for low and mid wind speeds." *Wind Engineering* 43, no. 4 (2019): 392-403.
- [25] Dalili, N., Afsaneh Edrisy, and Rupp Carriveau. "A review of surface engineering issues critical to wind turbine performance." *Renewable and Sustainable energy reviews* 13, no. 2 (2009): 428-438.
- [26] Sagol, Ece, Marcelo Reggio, and Adrian Ilinca. "Issues concerning roughness on wind turbine blades." *Renewable and Sustainable Energy Reviews* 23 (2013): 514-525.
- [27] Wright, A. K., and D. H. Wood. "The starting and low wind speed behaviour of a small horizontal axis wind turbine." *Journal of wind engineering and industrial aerodynamics* 92, no. 14-15 (2004): 1265-1279.
- [28] Clifton-Smith, M., D. H. Wood, and A. D. Wright. "Optimising design and construction for wind energy systems in low wind environments." *Wind energy systems: optimising design and construction for safe and reliable operation*. Woodhead Publ, Cambridge (2010): 370-391.
- [29] Pourrajabian, Abolfazl, Reza Ebrahimi, and Masoud Mirzaei. "Applying micro scales of horizontal axis wind turbines for operation in low wind speed regions." *Energy conversion and management* 87 (2014): 119-127.
- [30] Hornby, Albert Sydney, and Anthony Paul Cowie. *Oxford advanced learner's dictionary*. Vol. 1430. Oxford: Oxford university press, 1995.
- [31] Khan, Sikandar, Kamran Shah, Hamid Khan, Sajid Ali, Naveed Ahmad, Muhammad Abid, Haider Ali, and Mazhar Sher. "Observation of the starting and low speed behavior of small horizontal axis wind turbine." *Journal of Wind Energy* 2014 (2014): 1-8.
- [32] McConville, James B. *Introduction to mechanical system simulation using Adams*. SDC publications, 2015.

- [33] Sessarego, Matias, and David Wood. "Multi-dimensional optimization of small wind turbine blades." *Renewables: Wind, Water, and Solar 2*, no. 1 (2015): 1-11.
- [34] Auld, D.J., and Srinivas, K. (2005). *Aerodynamics for Students*. University of Sydney, Sydney, New South Wales, Australia.
- [35] Pourrajabian, Abolfazl, Masoud Mirzaei, Reza Ebrahimi, and David Wood. "Effect of air density on the performance of a small wind turbine blade: A case study in Iran." *Journal of Wind Engineering and Industrial Aerodynamics* 126 (2014): 1-10.
- [36] Vaz, Jerson RP, David H. Wood, Debanik Bhattacharjee, and Erb F. Lins. "Drivetrain resistance and starting performance of a small wind turbine." *Renewable energy* 117 (2018): 509-519.
- [37] Pourrajabian, Abolfazl, Peyman Amir Nazmi Afshar, Masoud Mirzaei, Reza Ebrahimi, and David H. Wood. "Hollow blades for small wind turbines operating at high altitudes." *Journal of Solar Energy Engineering* 138, no. 6 (2016).
- [38] Sirignano, William A. "Small Wind Turbines: Analysis, Design, and Application." *AIA Journal* 51, no. 8 (2013)
- [39] Korprasertsak, Natapol, and Thananchai Leephakpreeda. "Optimal design of wind boosters for low speed vertical axis wind turbines." In *Applied Mechanics and Materials*, vol. 798, pp. 195-199. Trans Tech Publications Ltd, 2015.
- [40] Kosasih, Buyung, and Andrea Tondelli. "Experimental study of shrouded micro-wind turbine." *Procedia Engineering* 49 (2012): 92-98.
- [41] Roy, Sukanta, and Ujjwal K. Saha. "Review of experimental investigations into the design, performance and optimization of the Savonius rotor." *Proceedings of the Institution of Mechanical Engineers, Part A: Journal of Power and Energy* 227, no. 4 (2013): 528-542.
- [42] Altan, Burçin Deda, Mehmet Atılğan, and Aydoğın Özdamar. "An experimental study on improvement of a Savonius rotor performance with curtaining." *Experimental thermal and fluid science* 32, no. 8 (2008): 1673-1678.
- [43] Altan, Burçin Deda, and Mehmet Atılğan. "An experimental and numerical study on the improvement of the performance of Savonius wind rotor." *Energy Conversion and Management* 49, no. 12 (2008): 3425-3432.
- [44] Altan, Burçin Deda, and Mehmet Atılğan. "The use of a curtain design to increase the performance level of a Savonius wind rotors." *Renewable Energy* 35, no. 4 (2010): 821-829.
- [45] Shikha, T. S. Bhatti, and D. P. Kothari. "Vertical axis wind rotor with concentration by convergent nozzles." *Wind Engineering* 27, no. 6 (2003): 555-959.
- [46] Shaughnessy, B. M., and S. D. Probert. "Partially-blocked Savonius rotor." *Applied Energy* 43, no. 4 (1992): 239-249.
- [47] Tartuferi, Mariano, Valerio D'Alessandro, Sergio Montelpare, and Renato Ricci. "Enhancement of Savonius wind rotor aerodynamic performance: a computational study of new blade shapes and curtain systems." *Energy* 79 (2015): 371-384.
- [48] El-Askary, W. A., M. H. Nasef, A. A. Abdel-Hamid, and H. E. Gad. "Harvesting wind energy for improving performance of Savonius rotor." *Journal of Wind Engineering and Industrial Aerodynamics* 139 (2015): 8-15.
- [49] Irabu, Kunio, and Jitendro Nath Roy. "Characteristics of wind power on Savonius rotor using a guide-box tunnel." *Experimental thermal and fluid science* 32, no. 2 (2007): 580-586.
- [50] Müller, Gerald, Mark F. Jentsch, and Euan Stoddart. "Vertical axis resistance type wind turbines for use in buildings." *Renewable Energy* 34, no. 5 (2009): 1407-1412.
- [51] Chong, W. T., A. Fazlizan, S. C. Poh, K. C. Pan, and H. W. Ping. "Early development of an innovative building integrated wind, solar and rainwater harvester for urban high rise application." *Energy and Buildings* 47 (2012): 201-207.
- [52] Chong, W. T., K. C. Pan, S. C. Poh, A. Fazlizan, C. S. Oon, A. Badarudin, and N. Nik-Ghazali. "Performance investigation of a power augmented vertical axis wind turbine for urban high-rise application." *Renewable Energy* 51 (2013): 388-397.
- [53] Kim, Daegyoun, and Morteza Gharib. "Efficiency improvement of straight-bladed vertical-axis wind turbines with an upstream deflector." *Journal of Wind Engineering and Industrial Aerodynamics* 115 (2013): 48-52.
- [54] Kim, Daegyoun, and Morteza Gharib. "Unsteady loading of a vertical-axis turbine in the interaction with an upstream deflector." *Experiments in fluids* 55, no. 1 (2014): 1658.
- [55] de Santoli, Livio, Angelo Albo, Davide Astiaso Garcia, Daniele Bruschi, and Fabrizio Cumo. "A preliminary energy and environmental assessment of a micro wind turbine prototype in natural protected areas." *Sustainable Energy Technologies and Assessments* 8 (2014): 42-56.
- [56] Pope, K., V. Rodrigues, R. Doyle, A. Tsopelas, R. Gravelins, G. F. Naterer, and E. Tsang. "Effects of stator vanes on power coefficients of a zephyr vertical axis wind turbine." *Renewable Energy* 35, no. 5 (2010): 1043-1051.
- [57] Pope, K., I. Dincer, and G. F. Naterer. "Energy and exergy efficiency comparison of horizontal and vertical axis wind turbines." *Renewable energy* 35, no. 9 (2010): 2102-2113.
- [58] Yao, Y. X., Z. P. Tang, and X. W. Wang. "Design based on a parametric analysis of a drag driven VAWT with a tower cowling." *Journal of Wind Engineering and Industrial Aerodynamics* 116 (2013): 32-39.

- [59] Chen, T-Y., and Y-Y. Chen. "Developing a vortical stator assembly to improve the performance of Drag-type vertical-axis wind turbines." *Journal of Mechanics* 31, no. 6 (2015): 693-699.
- [60] Burlando, Massimiliano, Alessio Ricci, Andrea Freda, and Maria Pia Repetto. "Numerical and experimental methods to investigate the behaviour of vertical-axis wind turbines with stators." *Journal of Wind Engineering and Industrial Aerodynamics* 144 (2015): 125-133..
- [61] Wang, Yan-Fei, and Mao-Sheng Zhan. "Effect of barchan dune guide blades on the performance of a lotus-shaped micro-wind turbine." *Journal of Wind Engineering and Industrial Aerodynamics* 136 (2015): 34-43.
- [62] Wang, Yan-Fei, and Mao-Sheng Zhan. "Guide blades' feasibility evaluation and its contribution to performance of a micro-wind turbine resembling lotus in shape." *Energy and buildings* 82 (2014): 709-718.
- [63] Chong, W. T., A. Fazlizan, S. C. Poh, K. C. Pan, W. P. Hew, and F. B. Hsiao. "The design, simulation and testing of an urban vertical axis wind turbine with the omni-direction-guide-vane." *Applied Energy* 112 (2013): 601-609.
- [64] Nobile, Rosario, Maria Vahdati, Janet F. Barlow, and Anthony Mewburn-Crook. "Unsteady flow simulation of a vertical axis augmented wind turbine: A two-dimensional study." *Journal of Wind Engineering and Industrial Aerodynamics* 125 (2014): 168-179.
- [65] Loganathan, Bavin, Harun Chowdhury, Israt Mustary, and Firoz Alam. "An experimental study of a cyclonic vertical axis wind turbine for domestic scale power generation." *Procedia Engineering* 105 (2015): 686-691.
- [66] Ali, Abdulkadir, Steve Golde, Firoz Alam, and Hazim Moria. "Experimental and computational study of a micro vertical axis wind turbine." *Procedia engineering* 49 (2012): 254-262.
- [67] Alam, Firoz, and Steve Golde. "An aerodynamic study of a micro scale vertical axis wind turbine." *Procedia Engineering* 56 (2013): 568-572.
- [68] Olsen, T., E. Lang, A. C. Hansen, M. C. Cheney, G. Quandt, J. VandenBosche, and T. Meyer. *Low Wind Speed Turbine Project Conceptual Design Study: Advanced Independent Pitch Control; July 30, 2002--July 31, 2004 (Revised)*. No. NREL/SR-500-36755. National Renewable Energy Lab., Golden, CO (US), 2004.
- [69] MacPhee, David William. *Flexible Blade Design for Wind Energy Conversion Devices*. University of California, San Diego, 2014.
- [70] Koutroulis, Eftichios, and Kostas Kalaitzakis. "Design of a maximum power tracking system for wind-energy-conversion applications." *IEEE transactions on industrial electronics* 53, no. 2 (2006): 486-494.
- [71] Letcher, Todd. "Small scale wind turbines optimized for Low Wind Speeds." In *24th Hayes Graduate Research Forum* (May, 2010)
- [72] FESTO Inc. (2014). *Self-optimising system for ultimate plant efficiency and process reliability*, FESTO, Esslingen, Baden-Wurttemberg, Germany.
- [73] PIV (2019), [www.dantecdynamics.com/measurement-principles-of-piv](http://www.dantecdynamics.com/measurement-principles-of-piv)
- [74] Allaei, Daryoush, and Yiannis Andreopoulos. "INVELOX: Description of a new concept in wind power and its performance evaluation." *Energy* 69 (2014): 336-344.
- [75] COMSOL (2019), <http://www.humusoft.cz/comsol/>
- [76] Allaei, Daryoush, David Tarnowski, and Yiannis Andreopoulos. "INVELOX with multiple wind turbine generator systems." *Energy* 93 (2015): 1030-1040.
- [77] Piezo-electric effect (2018), <http://www.explainthatstuff.com/piezoelectricity.html>
- [78] Rezaei-Hosseiniabadi, Nasrin, Ahmadreza Tabesh, Rasoul Dehghani, and Arash Aghili. "An efficient piezoelectric windmill topology for energy harvesting from low-speed air flows." *IEEE Transactions on Industrial Electronics* 62, no. 6 (2014): 3576-3583.
- [79] New Wind Inc. (2016), <https://www.arch2o.com/wind-turbine-tree-aeroleaves-newwind/>
- [80] Zephyr Energy (2019), [http://zephyrenergy.com/?page\\_id=1604](http://zephyrenergy.com/?page_id=1604)
- [81] EWICON (2013), <http://www.mecanoo.nl/Projects/project/61/Ewicon?t=6>
- [82] Paul Dvorak. "Dutch wind wheel generates electricity without moving parts," February 28, 2015. <https://www.windpowerengineering.com/dutch-wind-wheel-generates-electricity-without-moving-parts/>
- [83] Wesoff, Eric, and Stephen Lacey. "Solar Costs Are Hitting Jaw-Dropping Lows in Every Region of the World." *Green Tech Media* 27, no. 07 (2017).