

Conceptual Design and Structure Analysis of Giromill Vertical Axis Wind Turbine under Low Wind Speed

Open
Access

Mohamed Saiful Firdaus Hussin^{1,4,*}, Mohd Fariduddin Mukhtar^{1,7}, Mohd Zaidi Mohd Tumari^{2,5},
Nursabillilah Mohd Ali^{2,6}, Amir Abdullah Muhammad Damanhuri^{1,4}, Noor Saffreena Hamdan^{1,4},
Khairul Azri Azlan^{1,7}, Khairul Amri Tofrowaih^{1,4}

¹ Faculty of Mechanical & Manufacturing Engineering Technology, Universiti Teknikal Malaysia Melaka, Hang Tuah Jaya, 76100 Durian Tunggal, Melaka, Malaysia

² Faculty of Electrical & Electronics Engineering Technology, Universiti Teknikal Malaysia Melaka, Hang Tuah Jaya, 76100 Durian Tunggal, Melaka, Malaysia

³ Faculty of Electrical Engineering, Universiti Teknikal Malaysia Melaka, Hang Tuah Jaya, 76100 Durian Tunggal, Melaka, Malaysia

⁴ Centre for Advanced Research on Energy, Universiti Teknikal Malaysia Melaka, Hang Tuah Jaya, 76100 Durian Tunggal, Melaka, Malaysia

⁵ Centre for Robotics and Industrial Automation, Universiti Teknikal Malaysia Melaka, Hang Tuah Jaya, 76100 Durian Tunggal, Melaka, Malaysia

⁶ Centre for Telecommunication Research and Innovation, Universiti Teknikal Malaysia Melaka, Hang Tuah Jaya, 76100 Durian Tunggal, Melaka, Malaysia

⁷ Advanced Manufacturing Centre, Universiti Teknikal Malaysia Melaka, Hang Tuah Jaya, 76100 Durian Tunggal, Melaka, Malaysia

ARTICLE INFO

ABSTRACT

Article history:

Received 29 May 2020

Received in revised form 1 July 2020

Accepted 9 July 2020

Available online 15 September 2020

Unstable wind speed in Malaysia has been a problem for the wind turbine. Vertical axis wind turbine (VAWT) that is placed on the ground causes unnecessary stress and hinder it to perform at maximum performance. Thus, the purpose of this study was to analyze the behavior of VAWT at different wind speed. The conceptual design was generated by using the pugh method. Then the structure of the blade was analyzed in terms of displacement and von Mises stress, followed by topology optimization. Results show that peak stress for both forces applied and pressure applied was located at the center where maximum displacement is about 5.43×10^{-6} m while the maximum value of von Mises stress is about 0.9763Mpa at the edge of the blade and 0.6641MPa when pressure is distributed uniformly. Based on topology optimization, the blade area can still be reduced at the top and bottom part.

Keywords:

Giromill Blade; Low Wind Speed; Pugh Method; Topology Optimization

Copyright © 2020 PENERBIT AKADEMIABARU - All rights reserved

1. Introduction

Current modern wind turbines can be divided into two categories that are Horizontal Axis Wind turbines (HAWTs) and Vertical Axis Wind Turbines (VAWTs). The primary difference for both types of the wind turbines is the orientation of their axis of rotation. In general, HAWTs are more efficient than VAWTs in terms of producing electricity and it can be categorized as partial load operation and

* Corresponding author.

E-mail address: mohamed.saiful@utem.edu.my

<https://doi.org/10.37934/arfmts.75.2.1119>

full load operation [1-4]. Due to efficiency that HAWTs can generate more electricity than VAWTs, HAWTs become dominant commercialize in the wind power market. The main advantages for VAWTs are their capability to obtain wind from any direction [5]. Besides that, VAWTs do have a strong ability to resist wind compared with HAWTs and have much smaller noise than HAWTs as well. Although HAWTs is currently dominant in the wind power market [6], the potential capability of VAWTs to produce electricity at low wind speed cannot be denied. VAWTs can be further divided into three types, which are Darrieus wind turbine, Savonius wind turbine, and Giromill wind turbine. The curved blade design is to spread the bending stresses all over the blade by causing tension instead of bending [7]. The simplest design for the Savonius wind turbine is two half drums-like or cup-like fixed to a central shaft in opposite direction. The same person who created Darrieus wind turbine developed Giromill wind turbine. A Giromill wind turbine has a straight vertical blade which just replaces the Darrieus wind turbine curved blade design. Previously, Saha *et al.*, [8] designed VAWT in their works considering the aspect ratio and the diameter of rotor, without mentioning engineering design method. In a country like Malaysia, the wind speed is transient. According to Ibrahim *et al.*, [9], wind power density of Malaysia fell into class 1 as shown in Table 1.

Table 1
 Classes of wind power density

Wind Power Class	30 m		50 m	
	Wind Power Density (W/m ²)	Wind Speed (m/s)	Wind Power Density (W/m ²)	Wind Speed (m/s)
1	≤ 160	≤ 5.1	≤ 200	≤ 5.6
2	≤ 240	≤ 5.9	≤ 300	≤ 6.4
3	≤ 320	≤ 6.5	≤ 400	≤ 7.0
4	≤ 400	≤ 7.0	≤ 500	≤ 7.5
5	≤ 480	≤ 7.4	≤ 600	≤ 8.0
6	≤ 640	≤ 8.2	≤ 800	≤ 8.8
7	≤ 1600	≤ 11.0	≤ 2000	≤ 11.9

Class 1 normally considered as a moderate range of the rural power applications. The highest and lowest wind speed value in Malaysia is 3.9 m/s and 2.2 m/s respectively [10]. According to Najid *et al.*, [11], Malaysia can reach the highest wind speed of 15.4 m/s during the monsoon season. Most of the wind turbines have a cut-in speed range from 3 to 4 m/s [12]. Turbulent airflow will cause unnecessary stress on the blade and decreases its efficiency [13]. This investigation will focus on designing the concept of Giromill VAWTs, analyzing its displacement and stress distribution based on corresponding wind speed and optimizing the blade design in terms of material usage topologically. The factors listed in this paper later will expose the potential problems encountered by VAWTs and possible solution in solving the power generation at low wind speed.

2. Methodology

House of Quality (HOQ) helps in the planning process of designing Giromill wind turbine by examining the customer satisfaction information. In HOQ, there has a step to begin which are clarifying customer needs, interrelationship matrix, engineering characteristics, technical correlation matrix and target value/specification [14,15]. In order to fulfill all the customer needs some of the factor should be considered in constructing the house of quality. Engineering characteristics identify what the customer requires and it must be achieved to satisfy these requirements. Then, the relationship between customer requirements and product requirements will be evaluated. Morphological chart generated the possible solution to design Giromill wind turbine which helps to

give the idea in conceptual design section. In the pugh decision matrix, an alternative that is judged better than the datum is given a '+', and a '-' for a poorer alternative. When the alternative to be judged is about the same with the datum, it will be given an 'S' or 'O'. The sum of each '+', '-' and 'S' or 'O' responses are then evaluated with the chosen design. The highest rank will be chosen among the five design. For structure analysis, the pressure on the whole surface of the blade and the force applied on the edge of the blade is tested using simulation and result of displacement and von Mises stress is recorded. The value for pressure and force used is based on the wind speed stated in the previous section where maximum wind speed equal to 15.4 m/s. Moreover, the maximum pressure and force on the same location as stated above of the maximum allowable stress for the chosen material will be determined and compared with the result obtained from maximum wind speed. Lastly, topology optimization is carried out to generate the most optimal material distribution for the chosen design. Different from topography [16] analysis, the chosen design can have optimal stress distribution throughout the blade as wind penetrates on the blade and minimally used of material in developing the prototype.

3. Results

House of quality of Giromill wind turbine blades is shown by Figure 1. There are six customer's requirements need to be discussed, which include costs, lightweight, durability, flexibility, user friendly, and the amount of wind received. Besides that, engineering characteristics also have seven features which include density, weight of turbine, ultimate tensile strength, Young's modulus, impact strength, size of the turbine and improve safety. The first customer requirement is the cost of wind turbine blades. The cost of wind turbine blades has a strong relationship with the ultimate tensile strength. This means that as the higher the ultimate tensile strength, the higher the cost of wind turbine blades. Then, the weight of the turbine and Young's modulus are moderate relationship with the cost of wind turbine blades. While the density has weak relationship with the cost of wind turbine blades. The second customer requirement is lightweight wind turbine blades. The weight of turbine has the strongest relationship to the lightweight wind turbine blades. The weight of the turbines will affect the performance when it is too heavy. The ultimate tensile strength and Young's modulus have a moderate relationship to the lightweight of wind turbine blades while density has a weak relationship to the lightweight of wind turbine blades. Then, next customer requirement is durability of wind turbine blades. When comes to the durability of wind turbine blades, it is very important as it is the ability to withstand the wind pressure. Thus, ultimate tensile strength has the strongest relationship with the durability of wind turbine blades and impact strength and improve safety also have a very strong relationship to the durability of wind turbine blades. However, density and weight of the turbine did not have a relationship to the durability of wind turbine blades. Next customer requirement is the flexibility of the wind turbine blades. The wind turbine blades should be able to withstand the changes in length when under high wind pressure. Therefore, Young's modulus has the strongest relationship to the flexibility of the wind turbine blades. The next customer requirement is the ease to use of wind turbine. Although it does not have a strong relationship with other engineering characteristics, it still needs to be considered when making the wind turbine. The last customer requirement is the amount of wind received by the wind turbine. This is one of the most important requirements as the more wind received by the wind turbine, the higher the wind turbine rotation to generate the power electricity. Lastly, when all the relationship between customer requirements and engineering characteristics is evaluated, the average score and percentage of total value are calculated.

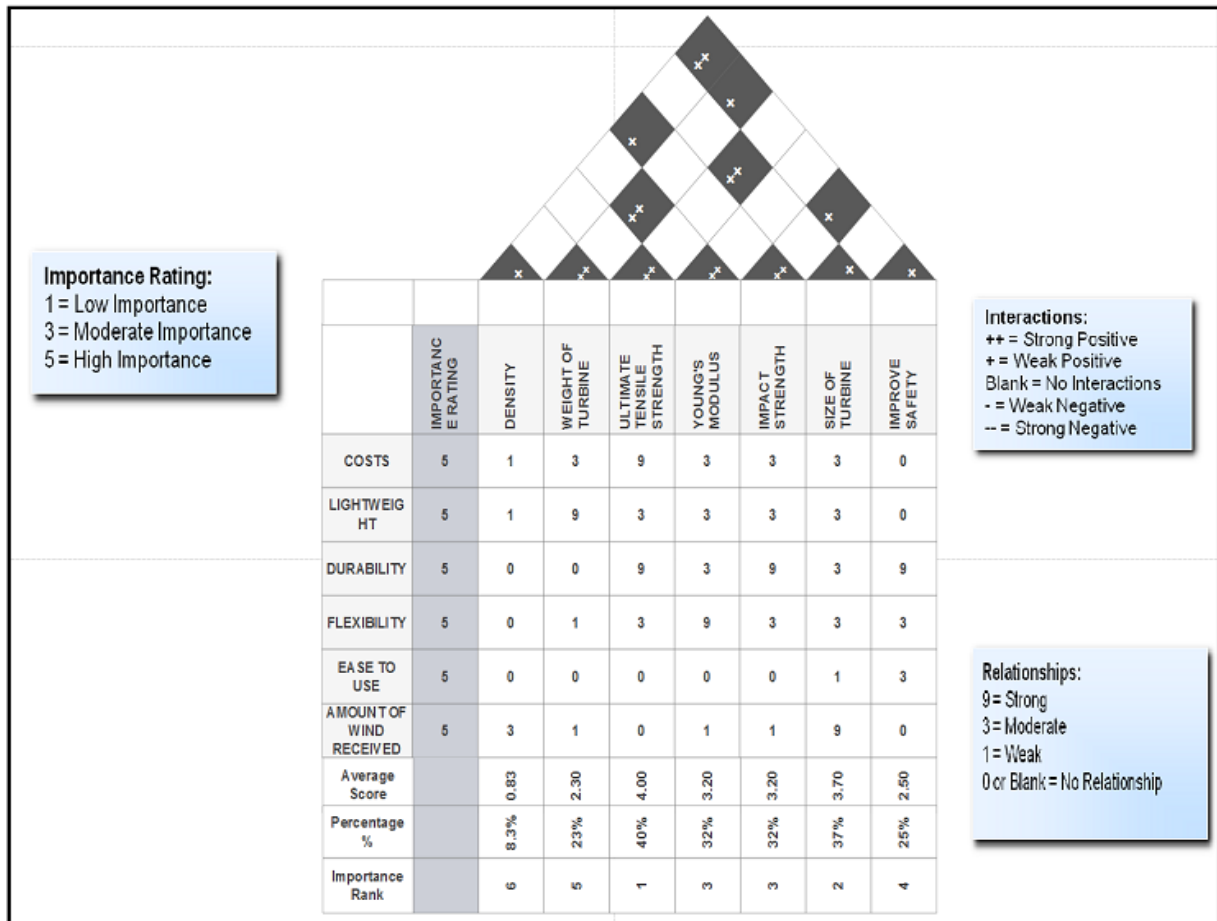

Fig. 1. House of quality

The rank shown in Figure 1 is to determine which engineering characteristics is the priority of producing the wind turbine blades. The most important engineering characteristics which are related to the customer requirement is ultimate tensile strength and then followed by the size of the turbine, Young's modulus, impact strength, improve safety, the weight of turbine and density. The result is interpreted into a morphological chart as shown by Table 2. From the morphological chart, 5 concepts as combined as shown in Table 3. The five chosen possible solutions as shown is then evaluated in the Pugh method section as shown by Table 4 in order to choose only one best concept design before fabricating the blade. Blade design 1 is chosen as datum or reference to compare with other blade design. From Table 4, the highest rank among the blade design is blade design 3 and blade design 5. However, blade design 5 is chosen among the five design. This is because blade D has a better aerofoil-like effect since it is in curve shape than the Blade C. Moreover, the blade connecting method of the second column has better stability as it supports the blade with two points but the method for iii only support the blade with one point only. Lastly, for the blade distance from rotor/hub, at distance of about 13.5 cm is the best as it has a better gap between the blade so that it is unable to hit the generator easily which is located bottom of the blade.

Table 2
 Morphological chart





Parameter	Possible Solution			
Chord Length	10 cm	15 cm	20 cm	25 cm
Blade design				
	A	B	C	D
Blade material	Polycarbonate	Titanium	Aluminium	Stainless steel
Blade connecting method				
	i	ii	iii	iv
Blade distance from rotor/hub	10 cm	12 cm	13 cm	13.5 cm

Table 3
 Selected concepts

Design No.	Possible Solutions								
1	10 cm	→	A	→	Polycarbonate	→	i	→	10 cm
2	15 cm	→	B	→	Titanium	→	ii	→	12 cm
3	20 cm	→	C	→	Aluminium	→	iii	→	12 cm
4	25 cm	→	D	→	Stainless Steel	→	iv	→	13 cm
5	20 cm	→	D	→	Aluminium	→	ii	→	13.5 cm

Table 4
 Pugh Method

	Blade Design Alternative				
	1 (reference)	2	3	4	5
Chord Length (cm)	S	+	+	+	+
Material Cost	S	-	+	+	+
Weight	S	-	-	-	-
Tensile Strength	S	+	+	+	+
Density	S	-	+	-	+
$\Sigma+$	0	2	4	3	4
Σ^2	5	0	0	0	0
$\Sigma-$	0	3	1	2	1
Rank		3	1	2	1

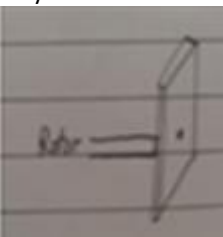
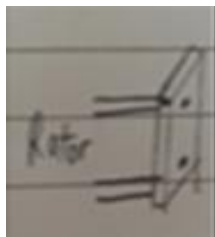
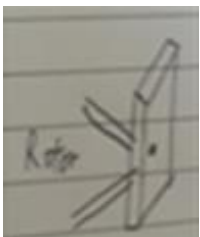
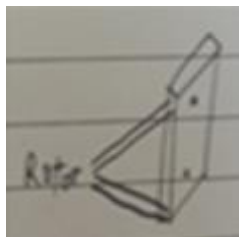
For point load, the force applied to the edge of the blade is in range of 0 to 0.9 N based on the maximum wind speed of 15.4 m/s while for uniform distributed pressure, a pressure in the range of 0 to 150 Pa is applied to the whole outside surface of the blade. Figure 2 and Table 5 shows that very small displacement involved and the force applied is directly proportional to the displacement.

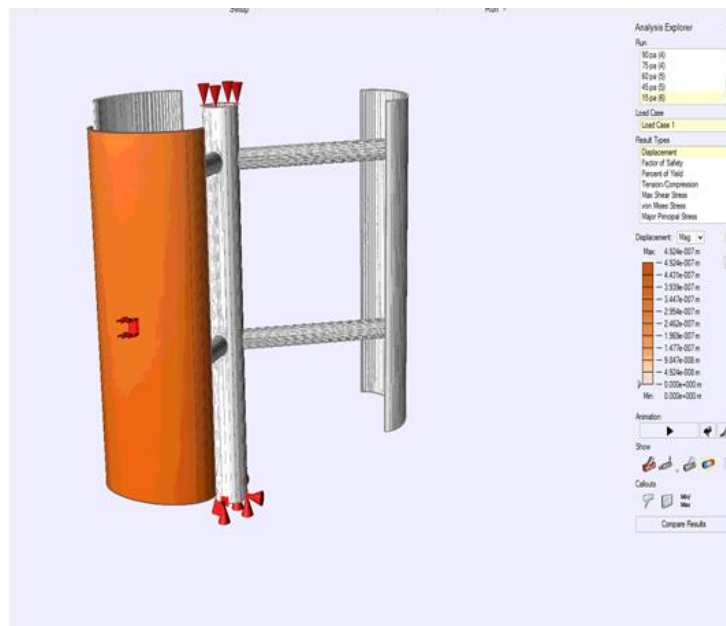

Fig. 2. Displacement Contour

Table 5
 Pressure vs Displacement

Pressure (Pa)	Displacement (m)
0	0
15	6.924E-7
30	1.377E-6
45	1.969E-6
60	2.462E-6
75	2.954E-6
90	3.447E-6
105	3.939E-6
120	4.431E-6
135	4.924E-6
150	5.432E-6

In Figure 3, it shows that the maximum von Mises stress obtained when pressure is uniformly distributed is 0.6641MPa. The value of stress is also directly proportional to the given pressure (Table 6). A study done by Liu and Xiao [17] shows that an unevenly distributed stress with a high-stress regime has been observed in their experiment. This situation is possibly due to the different stiffness value used in the experiment. On the other side, Micallef *et al.*, [18] concluded in their study that the use of substantial axial wake induction at the equator will lessen the power generation. On topology optimization shown by Figure 4, the blade area can be reduced at top and bottom parts. However, another study must be conducted to investigate whether the blade area in capturing pressure from wind is good enough to rotate the blade at a minimum rotational speed in generating power.

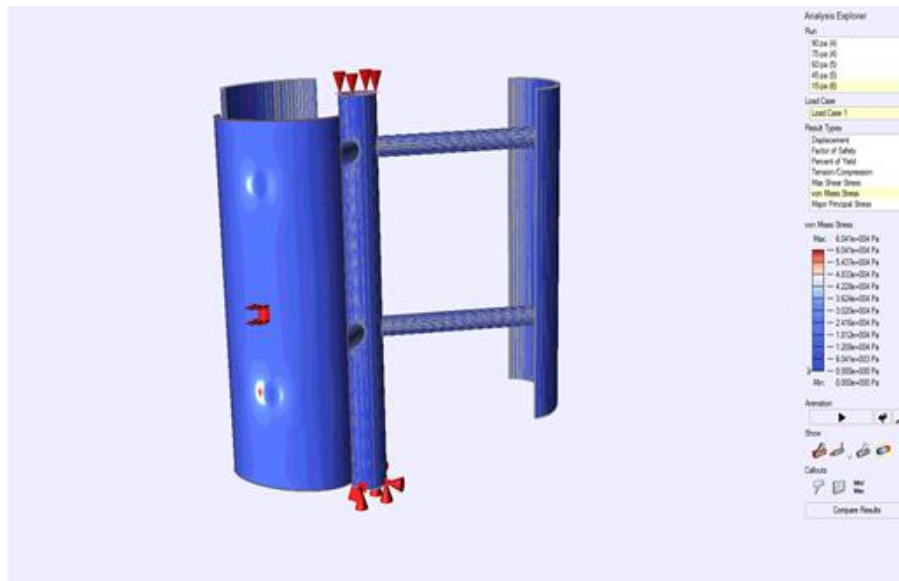

Fig. 3. Von Mises Stress Contour

Table 6
 Pressure vs Von Mises Stress

Pressure (Pa)	Von Mises Stress (MPa)
0	0
15	0.10041
30	0.18200
45	0.24120
60	0.30160
75	0.36200
90	0.42240
105	0.48280
120	0.54330
135	0.60370
150	0.66410

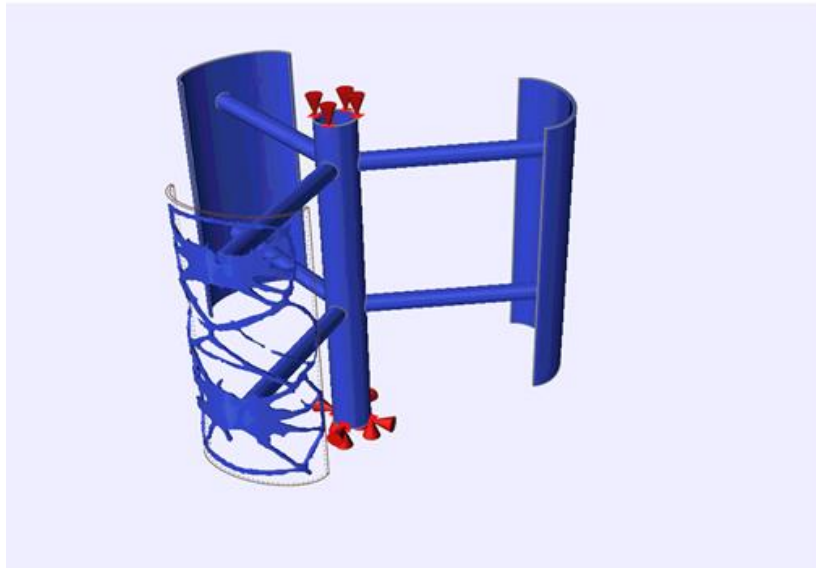

Fig. 4. Topology optimization

4. Conclusions

There were three objectives that need to be achieved for this project. The first objective was to design the concept of Giromill VAWT blade using the Pugh method. In order for this objective to be achieved, research about the VAWT was needed before the design phase can be produced. Thus, after research on Giromill VAWT had been done thoroughly, a few methods were used to aid in the design phase, which included the house of quality, morphological chart, Pugh Method and conceptual design. After a blade design chosen from conceptual design, SolidWorks software was used to draw the chosen blade design. The second objective was to analyze the performance of prototype design using finite element analysis. The prototype design was then simulated using SolidThinking software by determining the displacement and von Mises stress when load and pressure applied on the different location of the prototype design. The simulation results were showed that load and pressure on the side of the blade have the highest from the two aspects which are displacement and von Mises stress. The third objective of this project was to fabricate the prototype of Giromill VAWT. The prototype was fabricated successfully according to the parametric dimension.

Acknowledgement

Author would like to thank Universiti Teknikal Malaysia Melaka (UTeM) and Ministry of Higher Education (MOHE) for financial support under internal grant PJP/2018/FTK(7B)/S01599.

References

- [1] Vivek, C. M., P. Gopikrishnan, R. Muruges, and R. Raja Mohamed. "A review on vertical and horizontal axis wind turbine." *International Research Journal of Engineering and Technology (IRJET)* 4 (2017): 240-250.
- [2] Firdaus, H. M. S., M. Y. Halyani, E. Z. Ahmad, I. Norain, Z. M. Zulfattah, and M. S. Azizi. "Modeling and simulation of doubly fed induction generator for wind turbine." *ARPN Journal of Engineering and Applied Sciences* 11 (2006): 7331-7335.
- [3] Halyani, M. Y., H. M. S. Firdaus, M. S. Azizi, A. Tajul, and R. F. Farhana. "Modeling and simulation of wind turbine for partial load operation." *ARPN Journal of Engineering and Applied Sciences* 11 (2016): 4934-4941.
- [4] Halyani, M. Y., H. M. S. Firdaus, M. Zainon, E. Z. Ahmad, and I. Norain. "Modelling and simulation of a wind turbine with doubly fed induction generator in full load operation." *ARPN Journal of Engineering and Applied Sciences* 13 (2006): 57-63.

- [5] Mohamed, M. H., A. M. Ali, and A. A. Hafiz. "CFD analysis for H-rotor Darrieus turbine as a low speed wind energy converter." *Engineering Science and Technology, an International Journal* 18, no. 1 (2015): 1-13.
<https://doi.org/10.1016/j.jestch.2014.08.002>
- [6] Sanusi, Nortazi, Azami Zaharim, Sohif Mat, and Kamaruzzaman Sopian. "Comparison of Univariate and Bivariate Parametric Model for Wind Energy Analysis." *Journal of Advanced Research in Fluid Mechanics and Thermal Sciences* 49 (2018): 1-10.
- [7] Rossander, Morgan, Eduard Dyachuk, Senad Apelfröjd, Kristian Trolin, Anders Goude, Hans Bernhoff, and Sandra Eriksson. "Evaluation of a blade force measurement system for a vertical axis wind turbine using load cells." *Energies* 8, no. 6 (2015): 5973-5996.
<https://doi.org/10.3390/en8065973>
- [8] Saha, U. K., S. Thotla, and D. Maity. "Optimum design configuration of Savonius rotor through wind tunnel experiments." *Journal of Wind Engineering and Industrial Aerodynamics* 96, no. 8-9 (2008): 1359-1375.
<https://doi.org/10.1016/j.jweia.2008.03.005>
- [9] Ibrahim, Mohd Zamri, Yong Kim Hwang, Marzuki Ismail, and Aliashim Albani. "Spatial analysis of wind potential for Malaysia." *International Journal of Renewable Energy Research (IJRER)* 5, no. 1 (2015): 201-209.
- [10] Nik, W. B. W., M. F. Ahmad, M. Z. Ibrahim, K. B. Samo, and A. M. Muzathik. "Wind energy potential at east coast of peninsular Malaysia." *Journal of Applied Engineering Research* 2 (2011): 360-366.
- [11] Najid, Siti Khadijah, Azami Zaharim, Ahmad Mahir Razali, Mohd Said Zainol, Kamarulzaman Ibrahim, and Kamaruzzaman Sopian. "Analyzing the east coast Malaysia wind speed data." *International Journal of Energy and Environment* 3, no. 2 (2009): 53-60.
- [12] Belhamadia, Ahmed, Muhamad Mansor, and Mahmoud A. Younis. "A study on wind and solar energy potentials in Malaysia." *International Journal of Renewable Energy Research* 4, no. 4 (2014): 1042-1048.
- [13] El-Samanoudy, M., A. A. E. Ghorab, and S. Z. Youssef. "Effect of some design parameters on the performance of a Giromill vertical axis wind turbine." *Ain Shams Engineering Journal* 1, no. 1 (2010): 85-95.
<https://doi.org/10.1016/j.asej.2010.09.012>
- [14] Firdaus, H. M. S., M. Y. Halyani, M. I. H. C. Abdullah, and O. M. Rafi. "Flexible shield for impact resistant purpose: A conceptual design." *Proceedings of Mechanical Engineering Research Day 2017* (2017): 134-135.
- [15] Hussin, Mohamed Saiful Firdaus, Mohd Afdhal Shamsuddin, Ridhwan Jumaidin, Azrul Abidin, and Norhisyam Jenal Zakaria. "Portable grease trap for wastewater management system: A conceptual design approach." *Journal of Advanced Research in Fluid Mechanics and Thermal Sciences* 49, no. 1 (2018): 18-24.
- [16] Eman, U. N., H. M. S. Firdaus, M. Y. Halyani, Zulhasnizam Hasan, and R. F. Farhana. "Optimization of Stiffened Square Plate Topographically under Uniform distributed Pressure." In *MATEC Web of Conferences*, vol. 97, p. 01071. EDP Sciences, 2017.
<https://doi.org/10.1051/mateconf/20179701071>
- [17] Liu, Wendi, and Qing Xiao. "Investigation on Darrieus type straight blade vertical axis wind turbine with flexible blade." *Ocean Engineering* 110 (2015): 339-356.
<https://doi.org/10.1016/j.oceaneng.2015.10.027>
- [18] Micallef, Daniel, Russell Farrugia, Tonio Sant, and Pierluigi Mollicone. "An aerodynamic study on flexed blades for VAWT applications." In *Journal of Physics: Conference Series*, vol. 555, no. 1, p. 012073. 2014.
<https://doi.org/10.1088/1742-6596/555/1/012073>