



## Semarak International Journal of STEM Education

Journal homepage:

<https://semarakilmu.com.my/journals/index.php/sijste/index>

ISSN: 3030-5152

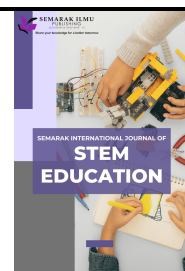

# Research Trends and Features of Programming in Mathematics Learning Environment: A Scoping Review

Masyithoh Md Zuber<sup>1,\*</sup>, Mohd. Asyraf Mansor<sup>1</sup>

<sup>1</sup> Pusat Pengajian Pendidikan Jarak Jauh, Universiti Sains Malaysia, 11800, Pulau Pinang, Malaysia

### ARTICLE INFO

#### Article history:

Received 5 August 2024

Received in revised form 10 August 2024

Accepted 15 September 2024

Available online 31 September 2024

#### Keywords:

Programming; mathematics instructional; primary school

### ABSTRACT

Programming abilities are increasingly integrated into global education structures. This skill emerges as a competitive advantage due to its capacity to cultivate inventors in the technological arena. Recognising this potential, many developed nations, including Sweden and the United Kingdom, began integrating programming into the primary school curriculum. Diverse methodologies are employed to conduct this implementation. Reviews of global programming trends in primary school mathematics education were the aim of this study. This study utilises data from the SCOPUS, ScienceDirect, and EBSCO search engines. Numerous empirical investigations have undergone a review procedure utilising the PRISMA methodology. Articles published between 2000 and 2024 were analysed. This article examines the interplay between mathematical concepts and programming, the programming features commonly incorporated into mathematics education, and the consequences of programming on primary mathematics learning. This article provides an in-depth discussion of practical implications and recommendations for further research from multiple perspectives.

## 1. Introduction

In the International Labour Organization (ILO) Worldwide Youth Employment Trends 2017 study for 1997 to 2017, the global youth labour force decreased significantly from 21.7% to 15.5% [1]. This research indicates that the youth face significant obstacles when marketing themselves in the job market. The research by Sidhu *et al.*, [2] indicated an urgent need for educating the youth aged 16 to 26 with Industry 4.0 technologies, as their awareness as well as readiness remain poor. Thus, youth should polish their skills and experiences, especially in the digital economy to enhance employment opportunities. The ability of the digital economy to create a decent return on investment and offer improved employment opportunities means that it can pave the way for a more sustainable economy through the production, adoption, and innovation of digital technology on a macro level. The ILO forecasts that by 2030, telecommunication networks will generate 24 million additional employments worldwide. Artificial intelligence (AI), robotics with computer programming, the

\* Corresponding author.

E-mail address: [masyithohmdzuber@student.usm.my](mailto:masyithohmdzuber@student.usm.my)

<https://doi.org/10.37934/sijste.3.1.4356>

Internet of Things (IoT), and 3D printing will dominate global youth employment patterns [1]. These technologies are ushering in a new wave of technical developments affecting future employment. Besides, the Member States of the United Nations have produced a 2030 Agenda of 17 Sustainable Development Goals (SDG) to improve the quality of human life and conserve the global environment. Goal 4 in SDG also, guaranteeing accessible and fair decent education and encouraging lifelong learning opportunities for everyone, is highlighted. In attaining this objective, digital skills were given the highest thematic emphasis.

Beginning in the year 2000, efforts were made to include digital skills in education curriculums across the globe. In schools, technology-based abilities such as digital skills, programming, and computer science are beginning to be utilised in class, extracurricular activities, summer camp and robotics competitions. Since 2000, the United States has implemented STEM, which combines Science, Technology, Engineering, and Mathematics, to cultivate a scientifically and technologically savvy and innovative workforce generation. England, on the other hand, was among the early nations to include Computer Science in its curriculum in 2013. In addition, Industrial Revolution (IR) 4.0, which ushers in a new wave of technology, is accompanied by a dynamic development in the educational landscape; programming education adds a new layer to students' digital skills. Besides allowing the students to explore new things through programming learning, they will also be able to think analytically, imaginatively, and competitively. Students who can think in this way are better prepared to meet the challenges of the modern workplace and the transition to IR 4.0. Additionally, TIMSS 2019 revealed that children who perform well in mathematics and science can access adequate learning materials [3]. Therefore, it is necessary to provide opportunities and exposure to all students, especially those in developing countries and remote communities, to narrow this gap in educational opportunities.

The modern youth have a strong attachment to technology. Most of these youth generations are consumers rather than innovators of technology. Therefore, programming is one of the potential soft skills that they should consider expanding. Programming enables students to utilize computers to express themselves, broadens the horizon of knowledge, and encourages the growth of computational thinking [4]. However, learning that incorporates programming concepts at the primary school level is challenging but engaging. Thus, programming activities must be simple to begin, encourage discovery, and accommodate diverse project perspectives to make it easier for people of different ages, experiences, and interests [4]. Programming therefore adds a new layer to the student's cognitive process. Thus, programming has been defined as constructing a process of a series of algorithms or pseudocode for a computer programme to execute according to commands and solve a problem [5]. In the 1980s, Seymour Papert was an early proponent of incorporating programming into the classroom. He believed that teachers and students will be benefited from this new programming knowledge. Papert highlighted to provide students room to construct their idea of a learning process and avoid misunderstandings, a notion and paradigm to carry out this programming-based learning need to be prepared [6]. It is because introducing programming into education without rigorous study might lead to enjoyment without much learning. Therefore, there is no assurance that the programming will enhance learning.

Programming exercises could encourage students' development in tinkering, abstraction, and generalisation when writing pseudocode, looping helps to assemble an effective solution, remixing and debugging are required when rectifying any faults in the coding algorithm. All these qualities will promote computational thinking capabilities [7]. This is because the process of conceptualising abstract issues and solutions in programming needs computational thinking skills [8]. Consequently, computational thinking and programming are deeply intertwined. Since the power to think and act imaginatively is one of the predictors of an individual's, a company's, a community, and even a

nation's survival [9]. However, there were many obstacles in the way of early attempts to introduce programming to students, including resource limitations and the nature of text-based programming languages were notoriously challenging for a young learner to master [4,10]. Hence, numerous initiatives in the new millennium sought to restore programming's prominence [11-13]. Thus, there is a need to understand the strengths of the welcoming programming environment and reduce obstacles as it will attract students to learn to program. It appears that programming abilities are being valued more and more in the era of IR 4.0. In their eagerness to utilise programming in instruction at the primary school, teachers and educational authorities must assess the material and consolidate the most effective pedagogical ways for implementing it. Hence, it is because learning programming seriously and focusing solely on programming abilities is not appropriate for primary school students since it might result in them quickly becoming bored and giving up [14]. Therefore, a little step technique is essential for bridging the gap between normal language and programming language [15]. This technique is extremely effective for adopting new learning tools so that beginners can gradually incorporate them with their existing knowledge.

Hence, it is necessary to examine the trends in prior research about programming intervention in mathematics education and the effects of programming integration in mathematics education as it will benefit teachers, schools, practitioners, educational researchers, and policymakers. Numerous scholarly investigations concerning the implementation of programming in education have been conducted. Luxton-Reilly *et al.*, [16] examines the emphasis on programming education, strategies of content delivery, and the tools employed in programming instruction generally. Forsström *et al.*, [17] analyses the programming software often used, with the common focus of studies and the impact of incorporating programming into mathematics education for students. The research conducted by Lindberg *et al.*, [18] concentrated exclusively on the gamification of programming education across seven countries. Holo *et al.*, [19] evaluated the focus on programming studies within mathematics education in primary schools. Nonetheless, these studies fail to elaborate on the strategies often employed, the mathematical concepts typically intertwined with programming, and the implications of programming on the mathematical growth of primary school students.

Consequently, this study aims to evaluate the often-employed strategy, the mathematical content frequently integrated with programming, and the significance of programming in mathematics education, particularly for the growth of primary school students. This study employs the scoping review methodology. Scoping review exerts the method of mapping findings by spanning together the literature from prior studies on a broad issue to identify gaps, explain essential concepts, report empirical evidence from carried out activities and identify prospects for future research [20]. In essence, producing such a review might shed light on the appropriateness and enhancement of a policy or practice. Besides, the study will answer the following research questions:

- RQ1: What are the primary school mathematical contexts to which programming have been applied?
- RQ2: What are the features of the programming interventions used in previous research that employed in primary school mathematical learning?
- RQ3: What is the implication of programming on primary school students' learning in mathematics.

## 2. Methodology

A reliable study relies on well-defined sources of information and undergoes screening to guarantee the quality and consistency of its objectives. This work uses systematic literature highlights to collect and analyse empirical studies from multiple papers comprehensively and transparently [21]

[22]. Such studies can provide a focused emphasis on the research topics, backed by extensive evidence, research findings selected based on explicit criteria, strict reliability evaluation, and verified inferences [23]. Articles were gathered and systematically reviewed, and the information obtained was analysed through a meta-analysis. The Preferred Reporting Items for Systematic Reviews and Meta-Analyses (PRISMA) checklist comprises 27 items that must be adhered to [24]. PRISMA is utilised for its capability to analyse extensive databases and facilitate precise searches based on the terminology employed in the study. Figure 1 illustrates the executed PRISMA procedure.



Fig. 1. PRISMA procedure [24]

## 2.1 Article Selection Process

### 2.1.1 Identification

The initial step involves the identification of keywords. To minimise bias within the search and selection of research articles, a peer review was performed by two independent assessors. An agreement must be established between the two independent assessors regarding the choice of pertinent articles and keywords. Following agreement on appropriate keywords, the article search procedure is executed on the selected data search engine. Searches utilise Boolean Operator and Truncation techniques within the search chain across three databases: Scopus, Science Direct, and EBSCO. Table 1 presents the keywords of the search chain of articles utilised in the search process.

Table 1

Search chain in database

<b>Scopus</b>	TITLE, ABSTRACT, KEYWORDS (("programming" OR "coding") AND "primary school" AND "mathematics")
<b>Science Direct</b>	(("programming" OR "coding") AND "primary school" AND "mathematics")
<b>EBSCO</b>	(("programming" OR "coding") AND "primary school" AND "mathematics")

Finally, a total of 712 articles were successfully gathered by the three databases.

### 2.1.2 Screening

The screening process commenced with the elimination of overlapping articles across the three databases. Subsequently, articles are evaluated based on the established inclusion and exclusion criteria. The inclusion criteria for article selection include articles published in a journal or proceeding, focus on empirical research, the assessors have access to the full article, and the article being written exclusively in English. Consequently, only 63 articles met the criteria established during the screening process. Table 2 presents the comprehensive selection and exclusion criteria.

**Table 2**  
 Inclusion and exclusion criteria

Criteria	Inclusion	Exclusion
Type of Article	journal article, proceeding article	books, thesis, dissertation
Year of Publication	2000-2024	before 2000
Search Engine	Scopus, Science Direct, Web of Science	Other than stated search engine
Subject	Mathematics	Other than mathematics
Research Sample	Primary School Students	Other than primary school students
Language	English	Other than English

63 screened articles were reviewed by researchers regarding their abstracts, content, and research findings to align with the research question. Following the evaluation process, only 31 articles were accepted. Certain articles failed to satisfy the inclusion requirements for this study as they merely addressed the general application of mathematics within science, technology, engineering, and mathematics (STEM) education, lacking a distinct focus on mathematical content.

#### 2.1.4 Included

A list of articles that were studied in this study is provided below (Table 3).

**Table 3**  
 The list of articles

No.	Author	Grade	Mathematics Topics	Learning Framework/ Concept
1,	Martin <i>et al.</i> , [25]	5 and 6	Mathematics concept	Concrete-Representational-Abstract (CRA) and language models
2.	Lodi <i>et al.</i> , [26]	5	Basic Mathematics operation	Modern Cryptography
3.	Tian <i>et al.</i> , [27]	3 to 7	Basics numbers	Game-based learning
4.	Polomes <i>et al.</i> , [28]	2 and 3	Ratio, proportion, percentage, proportional reasoning	Physical and digital twin
5.	Choi <i>et al.</i> , [29]	1 and 2	Basics numbers	Educational Data Mining (EDM)
6.	Eadaoin <i>et al.</i> , [30]	5 and 6	Geometry, measurements	Digital game-based learning
7.	Hu and Wong <i>et al.</i> , [31]	3	Basic numbers, problem-solving	Game-based learning
8.	Bento Miguens <i>et al.</i> , [32]	3	Geometry	Educational robotics
9.	Kopcha and Ocak [33]	5	Fraction, decimals	Meta-cognitive strategies
10.	Goltsiou and Sofianopoulon [34]	1	Geometry	Moodle Digital Environment
11.	Laurent <i>et al.</i> , [35]	4 and 5	Euclidean division, additive decomposition, fractions	Programming in Scratch
12.	Zhang <i>et al.</i> , [36]	4	Geometry	5Es Instructional model
13.	Karakostas <i>et al.</i> , [37]	2 to 6	Basic numbers	Algorithmic and deductive thinking
14.	Franchamps <i>et al.</i> , [38]	5 and 6	Grid (Coordinate)	“Sense-Reason-Act” SRA programming
15.	Babic <i>et al.</i> , [39]	1 to 3	Basic operation, basic numbers	Game-based learning
16.	Kong and Kwok [40]	6	Prime numbers, composite number	“To play, To think, To code” pedagogy
17.	Cui and Ng [41]	5 and 6	Basic operation, prime numbers, composite numbers, problem solving.	Mathematical thinking and computational thinking
18.	Torres-torres <i>et al.</i> , [42]	1, 4 and 5	Basic numbers	Introductory unplugged activities in the teaching

19.	Stigberg and Stigberg [43]	2, 6 and 9	Algebra, problem solving	
20.	Arfe <i>et al.</i> , [44]	1	Basic numbers, problem solving	“Programma il futuro”
21.	Ahmed <i>et al.</i> , [45]	1 to 3	Navigation symbols (Coordinate)	Didactic methods
22.	Olteanu [46]	6 and 7	Geometry	Reasoning and sense-making (rhizomatic assemblages)
23.	Folgien <i>et al.</i> , [47]	1	Problem-solving	Game-based learning
24.	Saez-Lopez <i>et al.</i> , [48]	6	Whole numbers, coordinates, negative numbers, problem-solving	Robotics in education
25.	Miller [49]	2	Geometry	Constructionism
26.	Citta <i>et al.</i> , [50]	1 to 5	Geometry, Coordinate	Unplugged approach/ Game-based learning
27.	Panskyi <i>et al.</i> , [51]	3 to 6		Creative programming/ game-based learning
28.	Calder [52]	6	Geometry, time	Digital learning
29.	Husain <i>et al.</i> , [53]		Coordinate, Geometry, money	Project-based learning
30.	Falloon [54]	6	Geometry, Basic numbers	A guided problem-based learning
31.	Taylor <i>et al.</i> , [55]	3 and 4		Interactive whiteboard (IWB)

### 3. Results

An integrative review was employed to analyse and synthesise the chosen papers. It assesses, narratively critiques, meta-analytically concludes, and thoroughly examines the impact of a study on a certain issue [56]. This integrated review synthesises the key findings of systematic and narrative reviews, serving as a supplemental resource. However, the rigorous scientific principles emphasised in a systematic study hinder an in-depth review of the study's perspective [57]. A narrative review addresses this limitation by exploring a problem in greater depth within the study's context. Hence the alignment of practice findings in the study can be achieved by formulating a comprehensive theme and interlinking each subject. Four primary stages must be undertaken to synthesise the concepts present in each article. Figure 3 illustrates the thematic synthesis process [58].

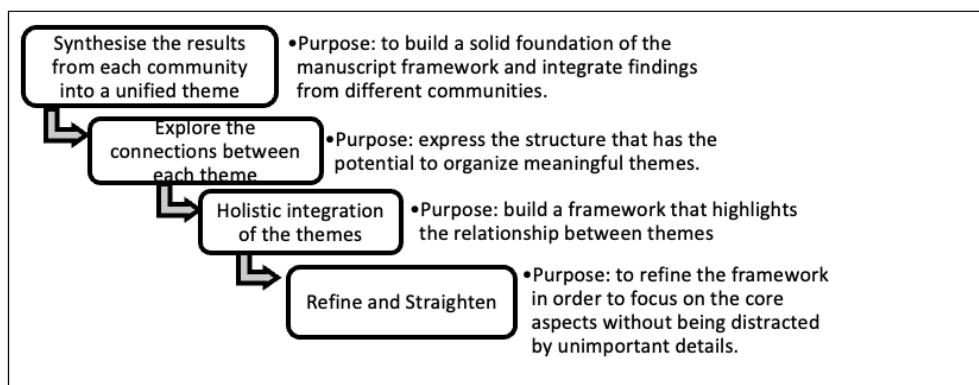
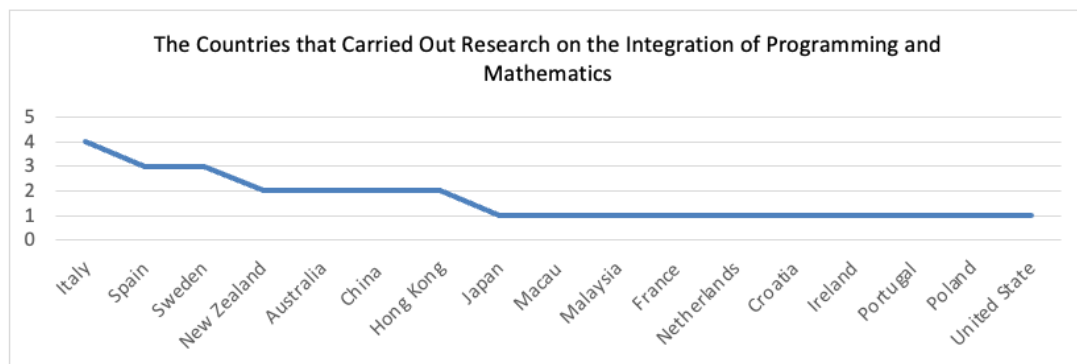

Fig. 2. Thematic synthesis process

The initial phase in the thematic analysis needs the researchers to conduct a preliminary reading to have an in-depth understanding of the substance of each article. Hence, the similarities and variances in the findings across each article have been analysed to construct relevant themes or

interconnected themes as a collective. The findings of each article were classified based on the type of data collected and categorised into low-level and high-level topics. Then both low-level and high-level themes were identified. These subordinate themes were synthesised to create overarching themes. These themes were analysed and associated topics were integrated. Finally, the relationships among each theme were examined to establish a framework that facilitates the resolution of the research questions and imparts significance. The themes were used to identify the most fundamental categories or links and to emphasise themes. Consequently, six themes emerged: the countries that studied the integration of programming and mathematics, the trend of the year of research on this topic, the type of programming that was frequently incorporated into mathematics education, the content of mathematics that was frequently incorporated into programming, concepts that were commonly employed in the integration of programming and mathematics, findings from the integration of programming and mathematics, and suggestions from the studies.

### 3.1 The Countries that Carried Out Research on the Integration of Programming and Mathematics



**Fig. 3.** The countries that carried out research on the integration of programming and mathematics

Italy leads in research on mathematics and programming integration at the primary school level, followed by Spain, Sweden, and fourteen other countries. Apart from Malaysia, all countries engaged in studies that include programming into mathematics education at the primary level are developed countries. Developed countries possess numerous advantages and more control in educational exploration due to a robust educational infrastructure, an emphasis on 21st-century learning, substantial financial resources for research, technological advancements, and industry demand. Although Malaysia is the sole developing nation recognised for proactively investigating the potential of programming in mathematics education. Educators in Malaysia were undertaking initiatives to enhance mathematics teaching in alignment with practices in other developed countries. Meanwhile, this trends also demonstrates that scholars from several countries were investigating the potential of utilising programming to learn mathematics. This advancement was seen when the MIT Media Lab launched block-based programming, designed for easy access by primary school students, in 2007. However, Scratch software introduced by MIT Media Lab attained stability only in 2019. In conjunction with the advancements, numerous block-based programming platforms were established, garnering the interest of educators. This demonstrates a commendable endeavour in diversifying mathematical learning activities and assessing the capacity of this programming to enhance the ability of primary school children.

### 3.2 The Trend of the Year of Research on Mathematics and Programming Integration

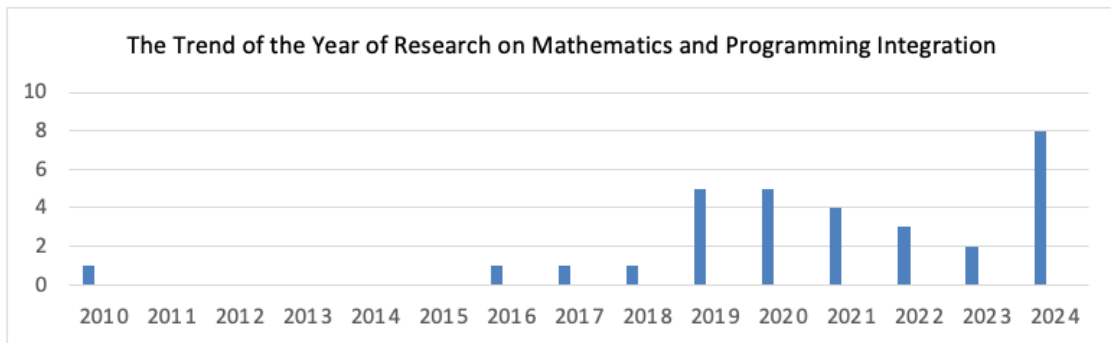

**Fig. 4.** The trend of the year of research on mathematics and programming integration

From 2000 to 2010, studies on programming in mathematics instruction concentrated only on secondary school and higher education levels. No related study has been done at the primary school level among the three search engines used. The years 2010, 2016, 2017, and 2018 indicate the occurrence of conducted studies. A significant spike commenced in 2019 and continued until 2024. Despite a slight decline observed from 2021 to 2023, investigations of this nature may have fallen because of the global impact of the Covid-19 epidemic. In 2024, the integration of mathematics and programming ought to once more be an ongoing subject of debate. This trend indicates that programming is progressively being introduced to primary school educators. This indicates that programming has begun its utilisation among primary school students.

### 3.3 The Type of Programming that was Frequently Incorporated into Mathematics Education

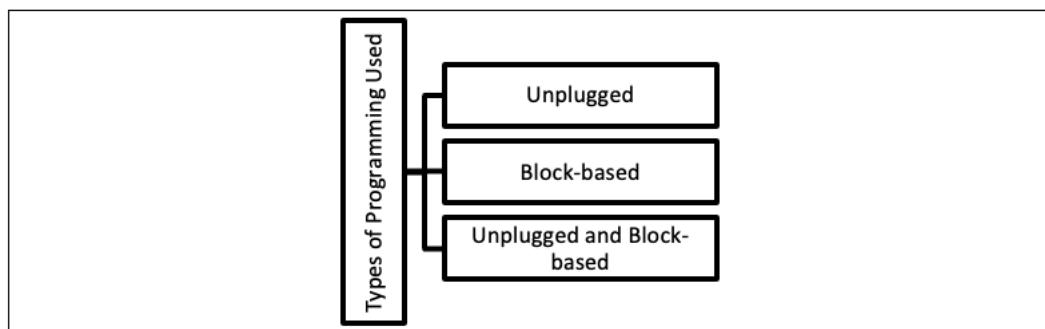

**Fig. 5.** The type of programming that was frequently incorporated into mathematics education

Three types of programming were commonly used in the integration of programming in mathematics education: unplugged, block-based, and a combination of unplugged and block-based techniques. Nonetheless, just one study incorporated unplugged and block-based programming within mathematics education. The researcher initiated the study by teaching programming through unplugged activities before progressing to block-based programming. While six studies exclusively employed unplugged methods for mathematics instruction. These studies mostly concentrate on level one primary school students. This is because employing unplugged, which is kinaesthetic, is more engaging and enjoyable for these students. The application of this programming commonly relies on game-based learning strategy. Subsequently, block-based programming emerged as the preferred method for programming. Block-based programming is interactive and could provide rapid feedback. So, it can stimulate students' enthusiasm for exploration in programming. Scratch was the



predominant platform, utilised in 16 studies. This is feasible due to Scratch being a platform that is both complimentary and facilitates free sharing online for the open exploration of students and educators. Other block-based programming used in those studies were mBot, Blockly, Moodle, Snap!, Arduino, and Code.org.

### *3.4 The Content of Mathematics that were Frequently Incorporated into Programming*

The mathematics topics that employed programming include general mathematics concepts, logical mathematics, mathematical operations, ratios, proportions, percentages, geometry, Euclidean division, measurement, additive decomposition, fractions, basic numbers, prime numbers, composite numbers, problem-solving, coordinates, decimals, and algebra. Geometry has been the subject most frequently associated with programming, followed by basic numerical concepts and problem-solving. Scratch enhanced geometry learning by enabling comprehension of geometric contexts through conducted experiments [50]. It could illustrate geometric concepts such as perimeter, angles, and rotation by presenting the functions of each learning concept. Altering the angle to either 60 or 90 degrees leads to a triangular or square shape. These notions can be shown with Scratch, and students can effectively observe the learning concept and apply it in practice. However, Panskyi *et al.*, [51], contended that lower-grade students do not demonstrate the ability to connect programming and mathematics. Even, Husain *et al.*, [53] asserted that the implications of programming on learning are not automatic; rather, they are highly dependent on student involvement in mathematics learning activities. Consequently, programming cannot be applied to all mathematical topics. The context of learning content and the structure of instructional mathematics in the classroom is crucial to achieving learning objectives.

### *3.5 Concepts that were Frequently Employed in the Integration of Programming and Mathematics*

Numerous concepts have been employed in these studies. Some studies highlighted theoretical frameworks, while others focus on essential skills and highlight relevant applications to support teaching and learning activities. Effective learning activities or environments were significantly influenced by the appropriate concept or framework. It is also capable of self-generalization for mathematics concepts and engaging the students with coding [48]. Further, the implications of the learning concepts in programming in mathematics education varied according to the concept chosen. Some of the concepts and framework that have been engaged in this kind of integration were the Concrete-Representation-Abstract (CRA) and language model, the 5Es Instructional model, Modern Cryptography, Educational Data Mining, the Moodle Digital Environment, meta-cognitive strategies, "Sense-Reason-Act" SRA programming, "To play, To think, To code" pedagogy, deductive thinking, inquiry-based learning, Mema-method, reasoning and sense-making, educational robotics, constructionism, unplugged approach, physical and digital learning, guided problem-based learning, and interactive whiteboard (IWB). However, game-based learning became the most common approach employed. According to Olteanu [46], game-based learning can facilitate student development by generating spontaneous meta-cognitive observations and discovering fresh ideas. This type of experience fosters positive reinforcement for students in terms of their emotions.

### *3.6 Findings from the Integration of Programming and Mathematics*

These 31 studies indicated the implications of programming in mathematics learning across two primary dimensions: cognitive and emotional. Integrating programming in mathematics learning did

influence other aspects of cognitive growth. Even though these 31 articles do not explicitly address the impact of the intervention on mathematical achievement, certain research indicates that this intervention can enhance students' comprehension of specific mathematical ideas. This practical application of mathematics within the intervention led to an enhancement in the understanding, and recognition of mathematical patterns, and the generation of mathematical concepts in students' understanding [48]. This is because students who engage in this intervention could recognise specific patterns and construct practical generalisations when combining coding context and mathematical context. Besides, other cognitive implications include computational thinking, algorithmic thinking, spatial reasoning, higher-order thinking skills, logical reasoning, critical thinking, and creative thinking. The most frequently observed skill in these studies is the improvement of computational skills, followed by enhancements in creative thinking, algorithmic thinking, logical thinking, and other cognitive abilities. Folgieri *et al.* [47] and Città *et al.* [50] research indicates that this intervention substantially enhances students' computational thinking. Students who participate in this type of intervention not only enhance their decomposition, abstraction, and pattern recognition abilities, but they also become proficient in time management and reduced errors [43]. These abilities enable students to manage their cognitive processes more efficiently and systematically. Thus, every problem or task will be thought in-depth by decomposing it into small parts before coming out with various possible solutions before making decisions accurately. Students were able to make decisions through the application of diverse strategies and establishing connections between the concepts. Later those process promotes the development of problem-solving skills in primary school students. These skills facilitate students in learning mathematics by enabling the application of concepts in diverse contexts.

Meanwhile, this integration can nurture students' interest and motivation in the classroom. An interactive platform like programming brings immediate feedback. Students can explore and experiment with several potential solutions they see possible and get the direct input. If the employed solution is correct, the coding that they write will achieve the objective. Conversely, if it fails, the student will recognise the errors that require alteration. This process allows instantaneous error correction and in depth understanding of the concept learned. This makes this kind of learning process more enjoyable for students who likes to try with different situation. Ultimately, these methods enable students to not only fulfil assignments but also engage actively in constructing understanding. Recognition of accomplishment in a finished work provides satisfaction to the learner and enhances their motivation to explore further and foster student confidence. An educational setting that combines programming and mathematics necessitates the exchange of ideas to structure coding. Thus, programming is commonly associated with a collaborative environment. Students utilise the space to engage in discussions and acquire knowledge, as evidenced by Calder [52] research. This opportunity indirectly fosters the development of ideas and collaborative learning among students.

Nonetheless managing programming and mathematics is challenging. Students with slower learning abilities may perceive the learning process as challenging and cognitively burdensome. Even for primary school students, establishing a relationship between the concepts of mathematics and programming is hard. Therefore, the learning process in this type of intervention must be systematically structured to enable students to progress from simple to complex concepts in an organised manner. Consequently, the choice of programming type, the preparation of learning activities, and the optimal technique must be carefully organised. This enables students to attain the specified objectives and provides a beneficial impact.

## 4. Conclusions

In conclusion, programming is appropriate for introduction to primary school children. This is due to the implementation of multiple mathematical learning environments by educators globally. Nonetheless, not all mathematical topics require integration with programming. The efficacy of programming is in its capacity to represent abstract and aid in understanding mathematics concepts, like coordinates and geometry. Thus, careful preparation is essential to ensure that programming difficulties do not hinder the enjoyment of learning mathematics and develop more opportunities for students to explore mathematics in meaningful ways. Hence, educators need support and guidance in incorporating programming into mathematics instruction effectively. The assistance encompasses not only instructional facilities but also ongoing courses and modules that assist educators in instruction.

## Acknowledgement

This research was not funded by any grant.

## References

- [1] Sukti, Dasgupta, Fernanda Bárca de Mattos, Brewer Laura, Elder Sara, Gardiner Drew, Larue Josée-Anne, Nebuloni Valter et al. *Global Employment Trends for Youth 2017: Paths to a better working future*. ILO, 2017.
- [2] Sidhu, Pramita, Fazlin Shasha Abdullah, and Mohamad Sirajuddin Jalil. "Awareness and Readiness of Malaysian Generation Z Students towards the Fourth Industrial Revolution (IR4. 0)." *Semarak International Journal of STEM Education* 1, no. 1 (2024): 20-27. <https://doi.org/10.37934/sijste.1.1.2027>
- [3] Mullis, I., M. Martin, P. Foy, D. Kelly, and B. Fishbein. *TIMSS 2019 International Reports—TIMSS & PIRLS International Study Center at Boston College*. Retrieved 2021-09-20, from <https://timssandpirls.bc.edu/timss2019/index.html>, 2020. <https://timss2019.org/reports/>.
- [4] Resnick, Mitchel, John Maloney, Andrés Monroy-Hernández, Natalie Rusk, Evelyn Eastmond, Karen Brennan, Amon Millner et al. "Scratch: programming for all." *Communications of the ACM* 52, no. 11 (2009): 60-67. <https://doi.org/10.1145/1592761.1592779>.
- [5] Pea, Roy D. 1983. "Logo Programming and Problem Solving." *Symposium of the American Educational Research Association*. Montreal, Canada.
- [6] Papert, Seymour. "New theories for new learnings." *School Psychology Review* 13, no. 4 (1984): 422-428. <https://doi.org/10.1080/02796015.1984.12085122>.
- [7] Shute, Valerie J., Chen Sun, and Jodi Asbell-Clarke. "Demystifying computational thinking." *Educational research review* 22 (2017): 142-158. <https://doi.org/10.1016/j.edurev.2017.09.003>.
- [8] Israel, Maya, Jamie N. Pearson, Tanya Tapia, Quentin M. Wherfel, and George Reese. "Supporting all learners in school-wide computational thinking: A cross-case qualitative analysis." *Computers & Education* 82 (2015): 263-279. <https://doi.org/10.1016/j.compedu.2014.11.022>.
- [9] Resnick, Mitchel. 2018. *Lifelong Kindergarten Cultivating Creativity through Projects, Passion, Peers, and Play*. First. The MIT Press.
- [10] Staub, Jacqueline, and Zaheer Chothia. "Large-Scale Analysis of Error Frequencies in Logo Programming." In *Proceedings of the 53rd ACM Technical Symposium on Computer Science Education—Volume 1*, pp. 571-577. 2022. <https://doi.org/10.1145/3478431.3499393>.
- [11] Kahn, Ken, and Harriette L. Spiegel. "The role of computer programming in education." *Journal of Educational Technology & Society* 2, no. 4 (1999): 6-9.
- [12] Lee, Greg C., and Jackie C. Wu. "Debug it: A debugging practicing system." *Computers & Education* 32, no. 2 (1999): 165-179. [https://doi.org/10.1016/S0360-1315\(98\)00063-3](https://doi.org/10.1016/S0360-1315(98)00063-3).
- [13] Freeman, Susan F., Beverly K. Jaeger, and Jennifer C. Brougham. "Pair programming: More learning and less anxiety in a first programming course." In *Proceedings of the ASEE Annual Conference*. 2003. <https://doi.org/10.18260/1-2--11728>.
- [14] Smith, Neil, Clare Sutcliffe, and Linda Sandvik. 2014. "Code Club." In *Proceedings of the 45th ACM Technical Symposium on Computer Science Education*, 517–22. New York, NY, USA: ACM. <https://doi.org/10.1145/2538862.2538919>.

- [15] Tamaki, Tatsuhiro, Atsushi Onishi, and Yasuo Uchida. "A Trial of Learning Programming Using a Six-step Method." *Asian Journal of Research in Education and Social Sciences* 3, no. 1 (2021): 10-24.
- [16] Luxton-Reilly, Andrew, Simon, Ibrahim Albluwi, Brett A. Becker, Michail Giannakos, Amruth N. Kumar, Linda Ott et al. "Introductory programming: a systematic literature review." In *Proceedings companion of the 23rd annual ACM conference on innovation and technology in computer science education*, pp. 55-106. 2018. <https://doi.org/10.1145/3293881.3295779>.
- [17] Forsström, Sanna Erika, and Odd Tore Kaufmann. "A literature review exploring the use of programming in mathematics education." *International Journal of Learning, Teaching and Educational Research* 17, no. 12 (2018): 18-32. <https://doi.org/10.26803/ijlter.17.12.2>.
- [18] Lindberg, Renny SN, Teemu H. Laine, and Lassi Haaranen. "Gamifying programming education in K-12: A review of programming curricula in seven countries and programming games." *British journal of educational technology* 50, no. 4 (2019): 1979-1995. <https://doi.org/10.1111/bjet.12685>.
- [19] Holo, O. E., E. N. Kveim, M. S. Lysne, L. H. Taraldsen, and F. O. Haara. 2022. "A Review of Research on Teaching of Computer Programming in Primary School Mathematics: Moving towards Sustainable Classroom Action." *Education Inquiry* 00 (00): 1–16. <https://doi.org/10.1080/20004508.2022.2072575>.
- [20] Collins, John A., Bart C.J.M. Fauser, Balancing the strengths of systematic and narrative reviews, *Human Reproduction Update*, Volume 11, Issue 2, March/April 2005, Pages 103–104, <https://doi.org/10.1093/humupd/dmh058>
- [21] Mohamed Shaffril, Hayrol Azril, Samsul Farid Samsuddin, and Asnarulkhadi Abu Samah. "The ABC of systematic literature review: the basic methodological guidance for beginners." *Quality & Quantity* 55 (2021): 1319-1346. <https://doi.org/10.1007/s11135-020-01059-6>.
- [22] Mohmad, Afiq Fikrie, Mohamad Solehuddin Mohamad Sidek, Roslinda Rosli, Siti Mistima Maat, and Muhammad Sofwan Mahmud. "Tinjauan Strategi menangani Diskalkulia melalui Sorotan Literatur Sistematis." *Jurnal Pendidikan Sains Dan Matematik Malaysia* 13, no. 2 (2023): 11-24. <https://doi.org/https://doi.org/10.37134/jpsmm.vol13.2.2.2023>.
- [23] Cook, Deborah J., Cynthia D. Mulrow, and R. Brian Haynes. "Systematic reviews: synthesis of best evidence for clinical decisions." *Annals of internal medicine* 126, no. 5 (1997): 376-380.
- [24] Moher, David, Alessandro Liberati, Jennifer Tetzlaff, Douglas G. Altman, and T. PRISMA Group\*. "Preferred reporting items for systematic reviews and meta-analyses: the PRISMA statement." *Annals of internal medicine* 151, no. 4 (2009): 264-269. <https://doi.org/10.1136/bmj.b2535>.
- [25] Martin, David A., Peter Curtis, and Petrea Redmond. "Primary school students' perceptions and developed artefacts and language from learning coding and computational thinking using the 3C model." *Journal of Computer Assisted Learning* (2024). <https://doi.org/10.1111/jcal.12972>.
- [26] Palomés, Xavier Pi I., Joan Verdagué-Codina, Pau Fonseca I. Casas, and José Luis Rubiés-Viera. "Physical and Digital Twin with Computational Thinking to Foster STEM Vocations in Primary Education." In *2024 IEEE Global Engineering Education Conference (EDUCON)*, pp. 1-8. IEEE, 2024. <https://doi.org/10.1109/EDUCON60312.2024.10578918>.
- [27] Lodi, Michael, Maria Cristina Carrisi, and Simone Martini. "Big Ideas of Cryptography in Primary School." In *Proceedings of the 2024 on Innovation and Technology in Computer Science Education V. 1*, pp. 206-212. 2024. <https://doi.org/10.1145/3649217.3653548>.
- [28] Tian, Ruochen, Daisuke Saito, Hironori Washizaki, Yoshiaki Fukazawa, Hiroshi Kobayashi, and Ayumi Tsuji. "Enhancing Programming Education through Game-Based Learning: Design and Implementation of a Puyo Puyo-Inspired Teaching Tool." In *Proceedings of the 55th ACM Technical Symposium on Computer Science Education V. 2*, pp. 1838-1839. 2024. <https://doi.org/10.1145/3626253.3635477>.
- [29] Choi, Wan-Chong, Chan-Tong Lam, and António José Mendes. "How Various Educational Features Influence Programming Performance in Primary School Education." In *2024 IEEE Global Engineering Education Conference (EDUCON)*, pp. 1-8. IEEE, 2024.
- [30] Slattery, Eadaoin J., Deirdre Butler, Kevin Marshall, Michael Barrett, Neeve Hyland, Michael O'Leary, and Laura P. McAvinue. "Effectiveness of a minecraft education intervention for improving spatial thinking in primary school children: A mixed methods two-level cluster randomised trial." *Learning and Instruction* 94 (2024): 102003. <https://doi.org/10.1016/j.learninstruc.2024.102003>
- [31] Hu, Jie, and Yanyu Wang. "Influence of students' perceptions of instruction quality on their digital reading performance in 29 OECD countries: A multilevel analysis." *Computers & Education* 189 (2022): 104591. <https://doi.org/10.1016/j.compedu.2022.104591>.
- [32] Bento Miguens, Ana Lúcia, João Manuel Nunes Piedade, Rui Jorge Bernardes dos Santos, and Tiago Lopes Oliva. "Meaningful learning in mathematics: a study on motivation for learning and development of computational thinking using educational robotics." *Educational Media International* (2024): 1-12. <https://doi.org/10.1080/09523987.2024.2357472>

- [33] Kopcha, Theodore J., and Ceren Ocak. "Children's computational thinking as the development of a possibility space." *Computers and Education Open* 5 (2023): 100156. <https://doi.org/10.1016/j.caeo.2023.100156>.
- [34] Goltsiou, Aikaterini, and Chrysa Sofianopoulou. "Utilizing Robotics in Maths in Primary Education A Case Study." In *2023 46th MIPRO ICT and Electronics Convention (MIPRO)*, pp. 867-871. IEEE, 2023. <https://doi.org/10.23919/MIPRO57284.2023.10159703>
- [35] Laurent, Manon, Rosamaria Crisci, Pascal Bressoux, Hamid Chaachoua, Cécile Nurra, Erica de Vries, and Pierre Tchounikine. "Impact of programming on primary mathematics learning." *Learning and Instruction* 82 (2022): 101667. <https://doi.org/10.1016/j.learninstruc.2022.101667>.
- [36] Zhang, Jing, Dong Han, Zhimin Wang, Hongchao Liu, and Hongliang Ma. "An Empirical Study on the Integration of Programming and Mathematics Course in Primary Schools." In *2022 4th International Conference on Computer Science and Technologies in Education (CSTE)*, pp. 117-122. IEEE, 2022. <https://doi.org/10.1109/CSTE55932.2022.00028>.
- [37] Karakostas, Athanasios, Vasilis Liarokapis, and Akrivi Vlachou. "Introducing algorithmic thinking in primary education in greece." In *2022 7th South-East Europe Design Automation, Computer Engineering, Computer Networks and Social Media Conference (SEEDA-CECNSM)*, pp. 1-6. IEEE, 2022. <https://doi.org/10.1109/SEEDA-CECNSM57760.2022.9932953>.
- [38] Fanchamps, Nardie LJA, Lou Slangen, Paul Hennissen, and Marcus Specht. "The influence of SRA programming on algorithmic thinking and self-efficacy using Lego robotics in two types of instruction." *International Journal of Technology and Design Education* 31 (2021): 203-222. <https://doi.org/10.1007/s10798-019-09559-9>.
- [39] Babić, Snježana, and Divna Bjelanović. "Programming and Mathematics through Game." In *2021 44th International Convention on Information, Communication and Electronic Technology (MIPRO)*, pp. 870-874. IEEE, 2021. <https://doi.org/10.23919/MIPRO52101.2021.9597117>.
- [40] Kong, Siu Cheung, and Wai Ying Kwok. "From mathematical thinking to computational thinking: Use scratch programming to teach concepts of prime and composite numbers." In *29th International Conference on Computers in Education Conference, ICCE 2021-Proceedings*, vol. 1, pp. 549-558. 2021.
- [41] Cui, Zhihao, and Oi-Lam Ng. "The interplay between mathematical and computational thinking in primary school students' mathematical problem-solving within a programming environment." *Journal of Educational Computing Research* 59, no. 5 (2021): 988-1012. <https://doi.org/10.1177/0735633120979930>.
- [42] Torres-Torres, Yucnary-Daitiana, Marcos Román-González, and Juan-Carlos Pérez-González. "Unplugged teaching activities to promote computational thinking skills in primary and adults from a gender perspective." *IEEE Revista Iberoamericana de Tecnologías del Aprendizaje* 15, no. 3 (2020): 225-232. <https://doi.org/10.1109/RITA.2020.3008338>
- [43] Stigberg, Henrik, and Susanne Stigberg. "Teaching programming and mathematics in practice: A case study from a Swedish primary school." *Policy futures in education* 18, no. 4 (2020): 483-496. <https://doi.org/10.1177/1478210319894785>.
- [44] Arfé, Barbara, Tullio Vardanega, and Lucia Ronconi. "The effects of coding on children's planning and inhibition skills." *Computers & Education* 148 (2020): 103807. <https://doi.org/10.1016/j.compedu.2020.103807>.
- [45] Ahmed, Gashawa, Jalal Nouri, LeChen Zhang, and Eva Norén. "Didactic methods of integrating programming in mathematics in primary school: Findings from a swedish national project." In *Proceedings of the 51st ACM technical symposium on computer science education*, pp. 261-267. 2020. <https://doi.org/10.1145/3328778.3366839>.
- [46] Olteanu, Constanta. 2020. "Programming, Mathematical Reasoning and Sense-Making." *International Journal of Mathematical Education in Science and Technology*. <https://doi.org/10.1080/0020739X.2020.1858199>.
- [47] Folgieri, Raffaella, Maria E. Vanutelli, Paola De Vecchi Galbiati, and Claudio Lucchiarì. "Gamification and coding to engage primary school students in learning mathematics: A case study." In *Proceedings of the 11th International Conference on Computer Supported Education*. 1, pp. 506-513. SciTePress, 2019. <https://doi.org/10.5220/0007800105060513>.
- [48] Sáez-López, José-Manuel, María-Luisa Sevillano-García, and Esteban Vazquez-Cano. "The effect of programming on primary school students' mathematical and scientific understanding: educational use of mBot." *Educational Technology Research and Development* 67, no. 6 (2019): 1405-1425. <https://doi.org/10.1007/s11423-019-09648-5>.
- [49] Miller, Jodie. 2019. "STEM Education in the Primary Years to Support Mathematical Thinking: Using Coding to Identify Mathematical Structures and Patterns." *ZDM - Mathematics Education* 51 (6): 915-27. <https://doi.org/10.1007/s11858-019-01096-y>.
- [50] Città, Giuseppe, Manuel Gentile, Mario Allegra, Marco Arrigo, Daniela Conti, Simona Ottaviano, Francesco Reale, and Marinella Sciortino. "The effects of mental rotation on computational thinking." *Computers & Education* 141 (2019): 103613. <https://doi.org/10.1016/j.compedu.2019.103613>.

- [51] Panskyi, Taras, Zdzislawa Rowinska, and Sebastian Biedron. "Out-of-school assistance in the teaching of visual creative programming in the game-based environment–Case study: Poland." *Thinking Skills and Creativity* 34 (2019): 100593. <https://doi.org/10.1016/j.tsc.2019.100593>.
- [52] Calder, Nigel Stuart. "Using Scratch to facilitate mathematical thinking." (2018). <https://doi.org/10.15663/wje.v23i2.654>.
- [53] Husain, Hafizah, Noorfazila Kamal, Mohd Faisal Ibrahim, Aqilah Baseri Huddin, and Anis Amirah Alim. "Engendering problem solving skills and mathematical knowledge via programming." *Journal of Engineering Science and Technology* 12, no. 12 (2017): 1-11.
- [54] Falloon, Garry. "Using simulations to teach young students science concepts: An Experiential Learning theoretical analysis." *Computers & Education* 135 (2019): 138-159. <https://doi.org/10.1016/j.compedu.2019.03.001>.
- [55] Taylor, Merylyn, Ann Harlow, and Michael Forret. "Using a computer programming environment and an interactive whiteboard to investigate some mathematical thinking." *Procedia-Social and Behavioral Sciences* 8 (2010): 561-570. <https://doi.org/10.1016/j.sbspro.2010.12.078>.
- [56] Cronin, Matthew A., and Elizabeth George. 2023. "The Why and How of the Integrative Review." *Organizational Research Methods* 26 (1): 168–92. <https://doi.org/10.1177/1094428120935507>.
- [57] John A. Collins, Bart C.J.M. Fauser, Balancing the strengths of systematic and narrative reviews, *Human Reproduction Update*, Volume 11, Issue 2, March/April 2005, Pages 103–104, <https://doi.org/10.1093/humupd/dmh058>
- [58] Lebar, Othman. 2021. *Penyelidikan Kualitatif Pengenalan Kepada Teori Dan Metode*. Ketiga. Batu Caves: Universiti Pendidikan Sultan Idris.