

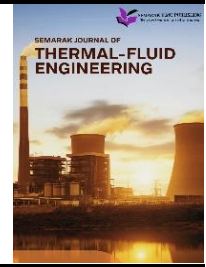

## Semarak Journal of Thermal-Fluid Engineering

Journal homepage:  
<https://semarakilmu.com.my/journals/index.php/sjotfe/index>  
ISSN: XXXX-XXXX



# Computational Fluid Dynamics of Corona Virus Dispersion in an Elevator Cabin due to a Sneeze

Ridwan Abdurrahman<sup>1</sup>, Muhammad Hazimuddin Halif<sup>2</sup>, Ishkrizat Taib<sup>1,\*</sup>, Mohammad Saifuddin Sukito<sup>2</sup>, Muhammad Ar-Rashid Norzali<sup>2</sup>, Muhammad Eric Zulkarnaen Azhar<sup>2</sup>, Muhammad Ikhwan Herman<sup>2</sup>, Muhammad Zulfadzli Md Zahri<sup>2</sup>

<sup>1</sup> Mechanical Engineering Department, Universitas Riau, Pekanbaru 28293, Indonesia

<sup>2</sup> Department of Mechanical Engineering, Faculty of Mechanical and Manufacturing Engineering, Universiti Tun Hussein Onn Malaysia, 86400, Parit Raja, Johor, Malaysia

### ARTICLE INFO

#### Article history:

Received 15 March 2024

Received in revised form 20 April 2024

Accepted 15 May 2024

Available online 6 June 2024

#### Keywords:

Covid-19; sneeze; dispersion; elevator cabin; computational fluid dynamic

### ABSTRACT

The COVID-19 pandemic has heightened the need to understand how viruses spread in enclosed spaces such as elevator cabins. This study aimed to address the knowledge gap regarding aerosol dispersion from sneezing in elevators through computational fluid dynamics (CFD) simulations. This highlights the role of the airborne transmission of COVID-19 and its increased likelihood in poorly ventilated areas. Methodologically, the study modelled an elevator cabin and simulated sneeze velocities of 1, 2, 3, and 4.5 m/s to analyse the flow regions, velocity, and pressure. These results indicate that higher sneeze velocities lead to enhanced aerosol spread, significantly increasing the potential for virus transmission. This demonstrates that proper air circulation and cleaning play crucial roles in reducing infection rates in elevators, thereby providing valuable insights for developing safety guidelines for such spaces.

## 1. Introduction

COVID-19 remains a primary global health threat, affecting overall human well-being and spreading easily from infected to uninfected populations. The virus is primarily transmitted through respiratory droplets produced when an infected person sneezes or coughs, particularly in enclosed spaces [1-2]. As a preventive measure, individuals are advised to practice social distancing [3-5]. Elevators are of particular concern regarding COVID-19 transmission because of their small, confined spaces, and generally inadequate air exchange. This study aims to model the spread of virus-laden droplets from carrier coughing or sneezing within an elevator cabin using Computational Fluid Dynamics (CFD) and ANSYS Fluent software [6].

COVID-19 poses a critical global threat, with human-to-human transmission being the primary mode of infection [7-9]. Failure to wear masks in confined spaces such as elevators can increase

\* Corresponding author.

E-mail address: [iszat@uthm.edu.my](mailto:iszat@uthm.edu.my)

<https://doi.org/10.37934/sjotfe.1.1.3442>

infection rates by a factor of 10 to 12 [10-12]. Understanding the dispersion patterns of sneeze droplets is crucial for minimising the spread of viruses [13-15]. This study modelled the extent to which COVID-19 virus particles can spread within an elevator cabin during sneezing events. Two scenarios were considered: normal breathing of a virus carrier and coughing of a virus carrier. The computational domain is modelled as an elevator cabin with two individuals: an infected COVID-19 patient who may cough or sneeze and another person standing at a certain distance from the patient. Recent research, particularly studies examining the effects of constitutive relations on sneezing behaviour in elevators, forms the foundation of this research [16-18].

This study aims to discuss the potential spread of COVID-19 virus particles in an elevator and the associated risks to other occupants. The study will compare the variation in virus mass fraction and Susceptible, Exposed, Infected (SEI) values obtained from the simulation with those from previous studies. By modelling the spread of COVID-19 particles within an elevator, this study seeks to enhance the understanding of virus transmission in confined spaces and recommend precautionary measures. To ensure a better understanding and transferability, the study will use other researchers' experimental work as benchmarks for the model's sneezing properties during the simulation testing method [19].

## 2. Methodology

### 2.1 Elevator Geometry and Person

The current model was designed in three dimensions using SOLIDWORKS, which is a commercial software package. The model geometry comprises an elevator cabin with dimensions of 2 m × 2 m × 2.8 m, as detailed in Table 1. Figure 1 illustrates both side and top views of the elevator. Of the two people in the model, one was designated as the patient and identified as the source of cough. Consequently, the inner surface of the patient's mouth is distinguished by an inlet-mouth boundary condition, as this surface serves as the reference boundary for the release of discrete-phase coronavirus particles. Figure 2 shows the parameters of the person modelled in the simulation.

**Table 1**  
Dimension for the residential elevator model

Dimension	Size
Length	2.0 m
Width	2.0 m
Height	2.8 m

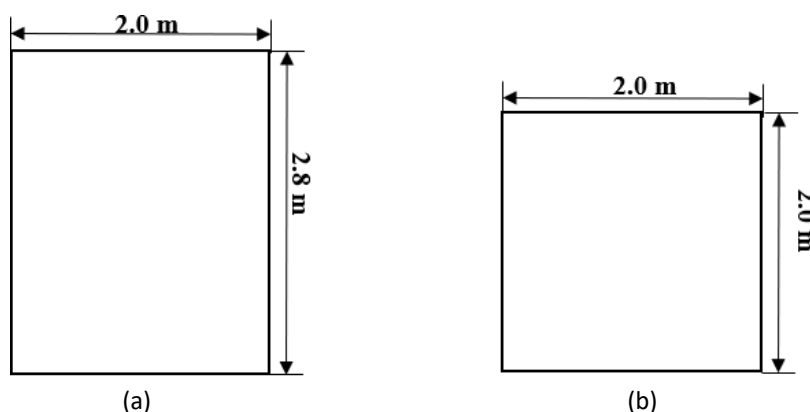
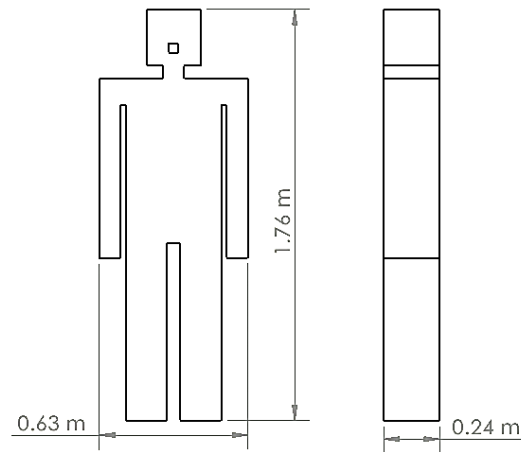

Fig. 1. (a) Side view of elevator (b) Top view of elevator

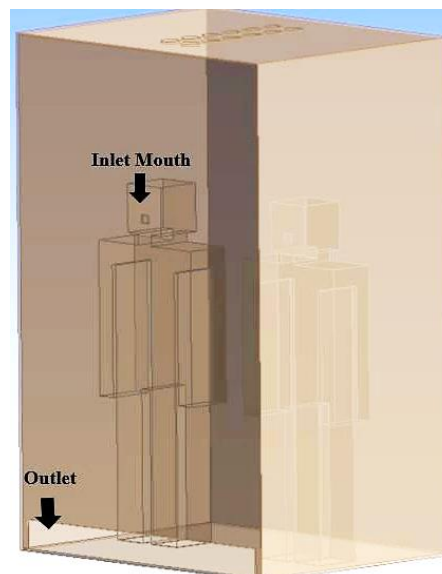

**Fig. 2.** Dimension of simplified mock people

## 2.2 Computational Fluid Dynamic (CFD)

### 2.2.1 Fluid domain

Several assumptions are made to simulate the proposed model. The numerical simulation was based on a pressure-based solver, and the gravity effect on the fluid was set to  $-9.81 \text{ m/s}^2$  along the y-axis. In addition, a simulation was conducted in a transient state. Figure 3 illustrates the flow-domain limitations of the elevator.



**Fig. 3.** The geometry of flow domain limitation in the elevator

### 2.2.2 Mesh generation

The grid is crucial because it uniquely represents the geometry of interest. The quality of the computational grid directly influences the rate of convergence, performance derived from the numerical analysis, and computational time required to run the analysis. In the current study, mesh cell sizes were developed with a narrower range along the blade in the elevator zone. Sufficient grid refinement across the interface improves the accuracy of the results. The fluid domains were entirely

composed of hex-dominant grids. This decision was based on the rationale that such grids can discretise complex geometries quickly and with minimal user intervention. Table 2 presents the mesh grid generation information.

**Table 2**

Mesh properties

Properties	Details
Element order	Linear
Element size	15.0 mm, 13 mm, 12 mm
Max size	26 mm
Mesh defeaturing	Yes
Defeature size	6.4 e-2 mm
Growth rate	1.2
Minimum edge length	2.0 mm

Figure 4 depict the surface mesh of the elevator, with Figure 4(a) representing the coarse mesh, Figure 4(b) representing, mid-fine mesh, and Figure 4(c) representing the fine mesh, respectively. Table 3 lists the numbers of nodes and elements for each mesh. The mesh size starts at 15 mm because above this size, the simulation solution fails. With a 14 mm mesh, the hybrid initialisation does not converge. The simulation calculation time was considerably longer for mesh sizes smaller than 12 mm becomes considerably longer.

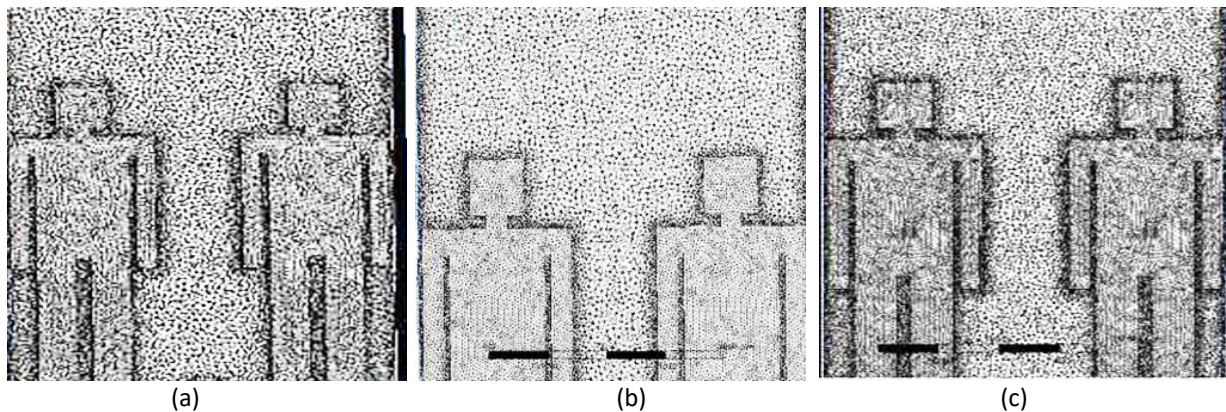

**Fig. 4.** Meshing of elevator (a) Coarse grid (b) Mid-fine grid (c) Fine grid

**Table 3**

Mesh properties

Mesh Class	Nodes	Element
Coarse Grid	806,144	3,518,189
Mid-Fine Grid	1,126,813	5,020,126
Fine Grid	1,367,630	6,153,970

### 2.2.3 Boundary condition

The boundary condition parameters are listed in the Table 4.

**Table 4**  
 Boundary condition parameter

Option	Items	Further option
Viscous	k-epsilon model	<i>k-epsilon</i>
	Near-wall treatment	RNG Standard wall function
Energy		On
Floor	Wall motion	<i>Wall</i>
	Heat flux	Stationary wall
	Discrete phase conditions	0 W. m <sup>-2</sup> Reflect
Walls of elevator	Wall motion	<i>Wall</i>
	Heat flux	Stationary wall
	Discrete phase conditions	0 W. m <sup>-2</sup> Trap
Inlet-mouth	Velocity magnitude	<i>Velocity inlet</i>
	Temperature	According to cases assign
	Discrete phase conditions	291 K escape
Outlet-air	Gauge pressure	<i>Pressure outlet</i>
	Discrete phase conditions	0 Pa Escape
Pressure coupling velocity	Pressure	<i>Coupled</i>
	Momentum	2 <sup>nd</sup> order
	Turbulent kinetic energy	1 <sup>st</sup> order upwind
	Turbulent dissipation rate	1 <sup>st</sup> order upwind
	Energy	1 <sup>st</sup> order upwind
Initialization		Hybrid initialization
Calculation	Number of time step	10
	Max iteration	10

### 2.3 Grid Independence Test

To validate the method employed in this study, the impact of the grid resolution on the flow prediction in the elevator was investigated. Based on existing experimental results, the sneezing condition was selected for the analysis. Three grids were created using the same geometry: coarse, mid-fine, and fine.

Table 3 lists the details of the grid developed for the domain. A coarse mesh was created with adjustments using a working solution, resulting in relatively few elements. Further refinement of the grid requires more manual tweaks to achieve superior grid quality. Mesh factors such as minimum sizing was also reduced, allowing for a greater number of elements. The meshing options for the studies were evaluated based on the numerical accuracy and the computational time required for solution convergence.

For the simulation, the mid-fine meshing category was selected as the optimal element size. This choice was made because its velocity performance is nearly equivalent to that of the fine category, but with significantly reduced simulation completion time. Mid-fine meshing proved to be the most efficient, demonstrating superior performance compared to the other meshing categories.

### 3. Results

#### 3.1 Velocity Distribution in the Elevator Cabin

Figure 5 illustrates the velocity distribution of the coronavirus dispersion at 1, 2, 3, and 4.5 m/s. At a sneeze velocity of 1 m/s, the simulation showed limited aerosol dispersion primarily confined near the source. This isometric view demonstrates that particles do not travel far from the sneezing individual, suggesting a lower risk of virus transmission at this velocity. At a sneeze velocity of 2 m/s (Figure 5(b)), the dispersion area increased notably. Aerosols spread further from the source, indicating a moderate increase in transmission risk. The expanded reach of the particles highlights the need for improved ventilation even at relatively low sneeze velocities. The 3 m/s scenario (Figure 5(c)) showed a significant increase in the dispersion area. The velocity magnitude and affected zone indicate a higher risk as aerosols travel more extensively within the cabin, potentially reaching other occupants. At 4.5 m/s, the dispersion was extensive, covering a large area within the elevator cabin, as illustrated in Figure 5(d). This increased velocity results in the spread of aerosols, posing a high risk of transmission. This scenario underscores the critical importance of efficient ventilation systems in mitigating such risks.

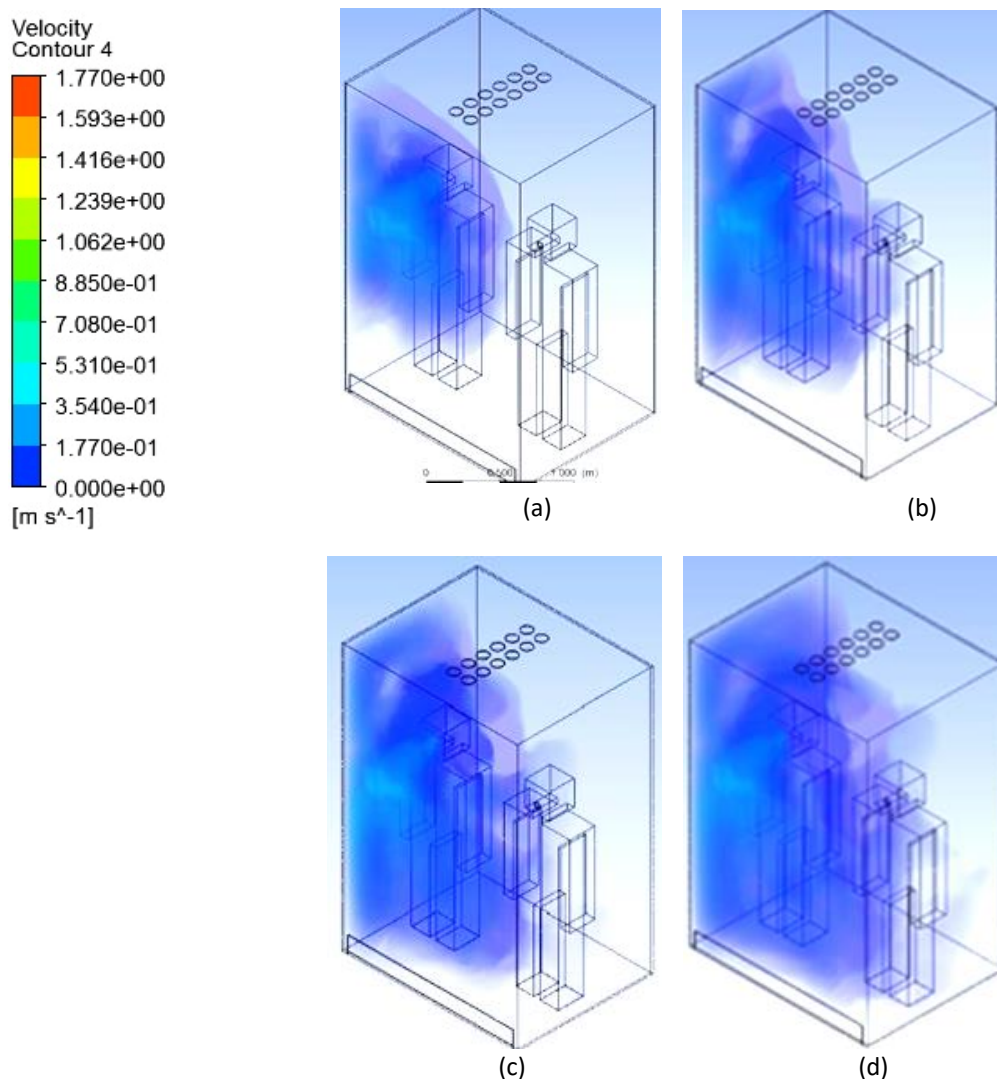
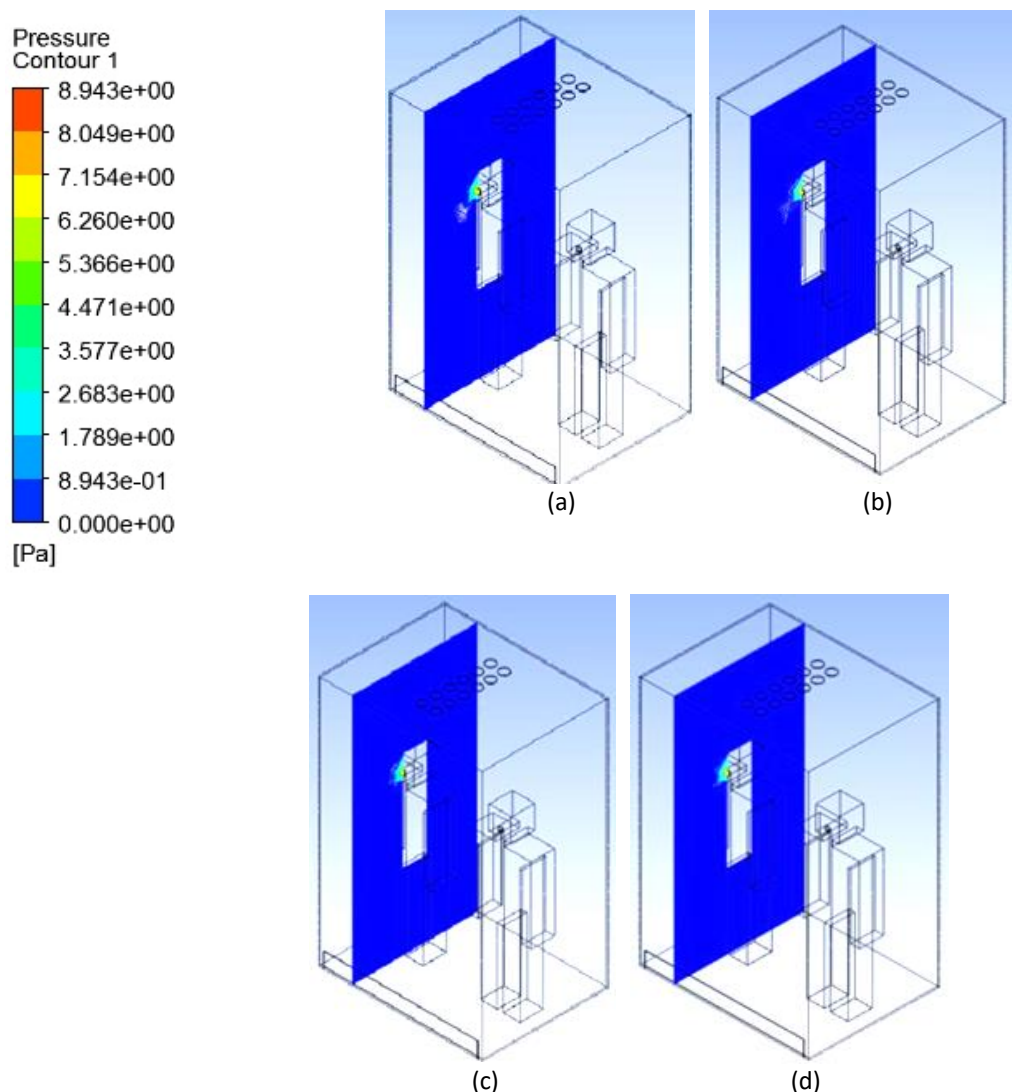

**Fig. 5.** The velocity distribution of the Corona Virus dispersion for (a) Case 1, velocity 1m/s (b) Case 2, velocity 2m/s (c) Case 3, velocity 3m/s (d) Case 4, velocity 4.5m/s



### 3.2 Pressure Distributions in the Elevator Cabin

Figure 6 illustrates the pressure contours at velocities of 1, 2, 3, and 4.5 m/s. For the 1 m/s case (Figure 6(a)), the pressure variations were minimal, indicating a limited impact on the surrounding air movement. The confined dispersion corresponds to low-pressure changes, suggesting contained aerosol spread. The 2 m/s scenario (Figure 6(b)) shows increased pressure, correlating with higher aerosol velocity and broader dispersion area. The pressure variations reflect a more extensive reach of the particles within the cabin. At 3 m/s (Figure 6(c)), the pressure further increased, aligning with the expanded aerosol spread. The simulation highlights the significant impact of the increased sneeze velocity on air movement and particle dispersion. The 4.5 m/s case (Figure 6(d)) exhibited the highest-pressure variations, indicating a substantial influence on the surrounding air. The extensive aerosol spread and significant pressure changes emphasise the heightened risk of virus transmission at this velocity.



**Fig. 6.** The pressure contour for (a) Case 1, velocity: 1 m/s (b) Case 2, velocity: 2 m/s (c) Case 3, velocity: 3 m/s (d) Case 4, velocity: 4.5 m/s.

## 4. Conclusion

The study observed different sneeze velocities in the test subjects without the presence of an air purifier. The results revealed that, while the sneeze velocities ranged from low to high, the spread varied according to the velocity. Based on this analysis, it can be concluded that sneeze velocities are directly proportional to the areas of transmission. In addition, the extent of the pressure contour increased as the sneeze velocity increased. The introduction of an air purifier is likely to slow the rate of infection by circulating and filtering sneeze particles. Such studies suggest that health and safety regulatory authorities should consider the impact of air purifiers and sanitisers on air circulation and droplet dispersion in enclosed areas.

Future ventilation and purification systems must be designed to effectively capture and remove droplets, rather than disperse them, thereby reducing the transmission of COVID-19. This study underscores the importance of proper air circulation and filtration in mitigating the spread of airborne pathogens in confined spaces.

## Acknowledgement

This research was supported by Universiti Tun Hussein Onn Malaysia (UTHM) through MDR (vot H504).

## References

- [1] Ali, Muhammad Ghafoor, Muhammad Owais Ahmad, and Saima Narjees Husain. "Spread of corona virus disease (COVID-19) from an outbreak to pandemic in the year 2020." *Asian Journal of Research in Infectious Diseases* 3, no. 4 (2020): 37-51. <https://doi.org/10.9734/AJRID/2020/v3i430135>
- [2] Almaghaslah, Dalia, Geetha Kandasamy, Mona Almanasef, Rajalakshimi Vasudevan, and Sriram Chandramohan. "Review on the coronavirus disease (COVID-19) pandemic: Its outbreak and current status." *International Journal of Clinical Practice* 74, no. 11 (2020): e13637. <https://doi.org/10.1111/ijcp.13637>
- [3] Chu, Derek K., Elie A. Akl, Stephanie Duda, Karla Solo, Sally Yaacoub, Holger J. Schünemann, Amena El-Harakeh et al. "Physical distancing, face masks, and eye protection to prevent person-to-person transmission of SARS-CoV-2 and COVID-19: A systematic review and meta-analysis." *The Lancet* 395, no. 10242 (2020): 1973-1987. [https://doi.org/10.1016/S0140-6736\(20\)31142-9](https://doi.org/10.1016/S0140-6736(20)31142-9)
- [4] Cheng, Vincent Chi-Chung, Shuk-Ching Wong, Vivien Wai-Man Chuang, Simon Yung-Chun So, Jonathan Hon-Kwan Chen, Siddharth Sridhar, Kelvin Kai-Wang To et al. "The role of community-wide wearing of face mask for control of coronavirus disease 2019 (COVID-19) epidemic due to SARS-CoV-2." *Journal of Infection* 81, no. 1 (2020): 107-114. <https://doi.org/10.1016/j.jinf.2020.04.024>
- [5] Maqbool, Annayath, and Noor Zaman Khan. "Analyzing barriers for implementation of public health and social measures to prevent the transmission of COVID-19 disease using DEMATEL method." *Diabetes & Metabolic Syndrome: Clinical Research & Reviews* 14, no. 5 (2020): 887-892. <https://doi.org/10.1016/j.dsx.2020.06.024>
- [6] Seman, Che Mohammad Hafizal Muzammil Che, Nur Ayuni Marzuki, Nofrizalidris Darlis, Noraini Marsi, Zuliazura Mohd Salleh, Izuan Amin Ishak, Ishkrizat Taib, and Safra Liyana Sukiman. "Comparison of hemodynamic performances between commercial available stents design on stenosed femoropopliteal artery." *CFD Letters* 12, no. 7 (2020): 17-25. <https://doi.org/10.37934/cfdl.12.7.1725>
- [7] Dhama, Kuldeep, Sharun Khan, Ruchi Tiwari, Shubhankar Sircar, Sudipta Bhat, Yashpal Singh Malik, Karam Pal Singh, Wanpen Chaicumpa, D. Katterine Bonilla-Aldana, and Alfonso J. Rodriguez-Morales. "Coronavirus disease 2019–COVID-19." *Clinical Microbiology Reviews* 33, no. 4 (2020): 10-1128. <https://doi.org/10.1128/cmr.00028-20>
- [8] Aljamali, Naghah Mahmood, Hasaneen Kudhair Abdullabass, Imad Kareem Alwan Alsabri, Nemah Sahib Mohammed Husien, Ahmed Adnan Abdul Hussein, and Wisam Hasan Ali Alfatoosi. "Review on Reasons for The Spread of Corona Virus." *International Journal of Cell Biology and Cellular Processes* 6, no. 1 (2020): 30-39p.
- [9] Ramesh, Naveen, Archana Siddaiah, and Bobby Joseph. "Tackling corona virus disease 2019 (COVID 19) in workplaces." *Indian journal of occupational and environmental medicine* 24, no. 1 (2020): 16-18. [https://doi.org/10.4103/ijocem.IJOEM\\_49\\_20](https://doi.org/10.4103/ijocem.IJOEM_49_20)
- [10] Singhal, Tanu. "A review of coronavirus disease-2019 (COVID-19)." *The Indian Journal of Pediatrics* 87, no. 4 (2020): 281-286. <https://doi.org/10.1007/s12098-020-03263-6>



- [11] Dbouk, Talib, and Dimitris Drikakis. "On airborne virus transmission in elevators and confined spaces." *Physics of Fluids* 33, no. 1 (2021). <https://doi.org/10.1063/5.0038180>
- [12] <https://doi.org/10.1063/5.0073694>
- [13] Pendar, Mohammad-Reza, and José Carlos Páscoa. "Numerical modeling of the distribution of virus carrying saliva droplets during sneeze and cough." *Physics of Fluids* 32, no. 8 (2020). <https://doi.org/10.1063/5.0018432>
- [14] Fontes, D., J. Reyes, K. Ahmed, and M. Kinzel. "A study of fluid dynamics and human physiology factors driving droplet dispersion from a human sneeze." *Physics of Fluids* 32, no. 11 (2020). <https://doi.org/10.1063/5.0032006>
- [15] Dhand, Rajiv, and Jie Li. "Coughs and sneezes: their role in transmission of respiratory viral infections, including SARS-CoV-2." *American journal of respiratory and critical care medicine* 202, no. 5 (2020): 651-659. <https://doi.org/10.1164/rccm.202004-1263PP>
- [16] Chigudu, Daniel. "Democratic Governance Of Sustainable Elections Under Covid-19 Condition In Africa: Strategic Considerations And Implications." *Journal of Positive School Psychology* 6, no. 9 (2022): 5161-5172.
- [17] Stiehl, Bernhard, Rajendra Shrestha, Steven Schroeder, Juanpablo Delgado, Alexander Bazzi, Jonathan Reyes, Michael Kinzel, and Kareem Ahmed. "The effect of relative air humidity on the evaporation timescales of a human sneeze." *AIP advances* 12, no. 7 (2022). <https://doi.org/10.1063/5.0102078>
- [18] Chumchan, Chartchay, Bunyong Rungroungdouyboon, and Phadungsak Rattanadecho. "Numerical Study of Cough Droplets Evaporation and Dispersion in an Indoor Environment Using the Multi-component Eulerian-Lagrangian Approach." *Engineered Science* 24 (2023): 901. <http://dx.doi.org/10.30919/es901>
- [19] Xie, Xiaojian, Yuguo Li, Hequan Sun, and Li Liu. "Exhaled droplets due to talking and coughing." *Journal of the Royal Society Interface* 6, no. suppl\_6 (2009): S703-S714. <https://doi.org/10.1098/rsif.2009.0388.focus>
- [20] England, Rory, Nicholas Peirce, Thamindu Wedatilake, Joseph Torresi, Simon Kemp, Malcolm Cook, Sean Mitchell, and Andy Harland. "The potential for airborne transmission of SARS-CoV-2 in sport: A cricket case study." *International Journal of Sports Medicine* 42, no. 05 (2021): 407-418. <https://doi.org/10.1055/a-1342-8071>